

TECHNICAL MANUAL

**ORGANIZATIONAL
MAINTENANCE MANUAL**

VOLUME II - PART 1

TROUBLESHOOTING

CHAPTER 1	
INTRODUCTION	1-1
CHAPTER 2	
SYMPTOM INDEXES	2-1
CHAPTER 3	
ARMAMENT FAULT ISOLATION DIAGRAMS	3-1
CHAPTER 4	
TURRET FAULT ISOLATION DIAGRAMS	4-1
FOLDOUTS	
EQUIPMENT LOCATION INFORMATION AND SCHEMATICS	

**TURRET
FOR
COMBAT ENGINEER VEHICLE,
M728
(2350-00-795-1797)**

This copy is a reprint which includes current pages from Changes 1 through 3.

HEADQUARTERS, DEPARTMENT OF THE ARMY

SEPTEMBER 1980

WARNING

BE CAREFUL: CARBON MONOXIDE IS A GAS THAT CAN KILL YOU.

Carbon monoxide is generated when something gets hot or burns - such as heaters, engines, etc. To keep carbon monoxide from making anyone sick or drowsy, there must be plenty of fresh air in the place where the heating or burning takes place. This gas has no color and no smell, but it is deadly poisonous. It can damage your brain, or kill you, if you do not have enough fresh air coming in to push the carbon monoxide out.

Follow these rules to keep from getting poisoned:

1. Do not operate engine or heater inside a building unless there is plenty of fresh air coming in.
2. Do not idle an engine unless you are sure there is plenty of fresh air in personnel compartments.
3. Do not drive a vehicle which has missing inspection plates, cover plates, or engine compartment doors except for very short maintenance times when necessary.
4. When operating vehicle, always be on the lookout for personnel who seem to be getting sick or drowsy. If you notice this happening, immediately get fresh air into personnel compartments. If this does not help, remove sick or drowsy personnel from vehicle and do the following:
 - a. Put him into fresh air.
 - b. Keep him covered.
 - c. Keep him still. Do not let him exercise. (Exercise will make him worse.)
 - d. Give him artificial respiration, if necessary.
 - e. Get medical help.

WARNING

**WARNING
RADIATION HAZARD**

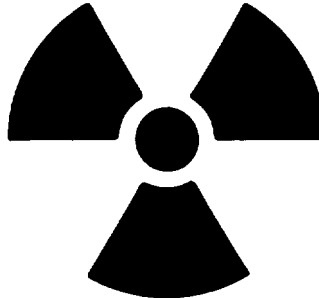

Azimuth dial pointers in indicator may be tipped with radioactive material. This becomes dangerous when dial window is broken or removed, When this happens, make repairs as soon as possible.

If dial window is broken or removed, all maintenance must be done at depot level only, except replacement of lamps or replacement of whole indicator unit.

Protecting, handling, storing, and getting rid of radioactive material must be done in accordance with TB MED-232 and TB 750-237.

WARNING

When placing the turret (elev/trav) power switch in the ON position, ensure that the gunner's power control handles are not displaced. If handles are displaced, rapid movements of the turret traverse in azimuth may result in fatal injury.

WARNING

When turret is in the power mode the gun will elevate and depress without depressing the magnetic brake switch on the gunner's control handles,

WARNING

Assure crew are in safe positions and driver has lowered his seat and has head down before operating in power or manual traversing or elevating modes.

WARNING

Do not release magnetic brake switch or override in magnetic brake actuator while traversing until gunner's or commander's power control is returned to neutral position. This will reduce unnecessary wear and/or damage to magnetic brake.

WARNING

To prevent injury to personnel, remove all ammunition from weapons before start of troubleshooting.

WARNING

Before traversing turret or elevating/depressing gun check outside of tank and surrounding area for unwary personnel. Make sure crew members are in safe positions and driver has lowered his seat and has his head down.

WARNING

Manual traversing handle may spin when power is turned on. Stay out of path of manual traversing handle.

WARNING

Use safety gloves when handling wire-rope staylines and winch cables.

WARNING

To prevent injury to personnel, stay clear of boom cable swing area.

WARNING

If not latched, breech operating handle will spring up violently when breech is closed.

L I S T OF EFFECTIVE PAGES

INSERT LATEST CHANGED PAGES. DESTROY SUPERSEDED PAGES.

NOTE: The portions of the text affected by the changes are indicated in the outer margins of the page. Changes to illustrations are indicated by miniature pointing hands. Changes to wiring diagrams are indicated by shaded areas.

Dates of issue for original and changed pages are:

Original 15 September 1980

TOTAL NUMBER OF PAGES IN THIS PUBLICATION IS 263 CONSISTING OF THE FOLLOWING:

Page	Change No.	Page	Change
Cover	0		
a - c	0		
A	0		
Blank	0		
i	0		
ii	0		
1-1 - 1-7	0		
1-8 Blank	0		
2-1 - 2-5	0		
2-6 Blank	0		
3-1 - 3-156	0		
4-1 - 4-75	0		
4-76 Blank	0		
F 0 - 1 - F 0 - 8	0		
Metric conversion chart	0		
Cover	0		

• Zero in this column indicates an original page.

CHANGE

No. 3

HEADQUARTERS
DEPARTMENT OF THE ARMY
Washington, DC 31 October 1990

**ORGANIZATIONAL MAINTENANCE MANUAL
VOLUME II - PART 1
TROUBLESHOOTING, TURRET
FOR
COMBAT ENGINEER VEHICLE,
M728 (2350-00-795-1797)**

TM 9-2350-222-20-2-2-1, 15 September 1980, is changed as follows:

1. Remove old pages and insert new pages as indicated below.
2. New or changed material is indicated by a vertical bar in the margin of the page.

Remove Pages

Insert Pages

3-47 and 3-48

3-47 and 3-48

3. File this change sheet in back of the publication for reference purposes.

By Order of the Secretary of the Army:

CARL E. VUONO
General, United States Army
Chief of Staff

Official:

THOMAS F. SIKORA
Brigadier General, United States Army
The Adjutant General

DISTRIBUTION:

To be distributed in accordance with DA Form 12-37E, (Block 1506),
Unit Maintenance requirements for TM 9-2350-222-20-2-2-1.

CHANGE
NO. 2

HEADQUARTERS
DEPARTMENT OF THE ARMY
WASHINGTON, D.C.

14 February 1986

**ORGANIZATIONAL MAINTENANCE MANUAL
VOLUME II- PART 1
TURRET
FOR
COMBAT ENGINEER VEHICLE
M728
(2350-00-795-1797)**

TM 9-2350-222-20-2-2-1 ,15 September 1980, is changed as follows:

1. Remove old pages and insert new pages as indicated below.
2. New or changed material is indicated by a vertical bar in the margin of the page.

Remove Pages

Insert Pages

2-3 and 2-4

2-3 and 2-4

File this change sheet in front of the publication for reference purposes.

By Order of the Secretary of the Army:

JOHN A. WICKHAM, JR.
General, United States Army
Chief of Staff

Official:

MILDRED E. HEDBERG
Brigadier General, United States Army
The Adjutant General

DISTRIBUTION:

To be distributed in accordance with DA Form 12-37, Organizational maintenance requirements for Vehicle, Combat Engineer, Full Tracked, M728.

CHANGE
NO. 1

HEADQUARTERS
DEPARTMENT OF THE ARMY
Washington, DC13 August 1985

ORGANIZATIONAL MAINTENANCE
COMBAT ENGINEER VEHICLE
FULL TRACKED, M728
NSN (2350-00-795-1797)
(TURRET)

TM 9-2350-222-20-2-2-1, 15 September 1980, is changed as follows:

1. Remove old pages and insert new pages as indicated below.
2. New or changed material is indicated by a vertical bar in the margin of the page.

Remove Pages	Insert Page
2 6 2-3 through 2-6 3-5 and 3-6 3-13 through 3-16 3-27 and 3-28 3-57 through 3-64 3-67 through 3-74 3-85 through 3-88 3-93 through 3-96 3-99 and 3-104 3-111 through 3-116 3-129 and 3-130 3-133 and 3-134 3-137 through 3-146 3-151 through 3-156 4-1 and 4-2 4-5 through 4-6 4-13 and 4-14 4-19 and 4-20 4-29 and 4-30 4-37 and 4-38 4-43 through 4-46 4-57 and 4-58 4-67 and 4-68	NONE 2-3 through 2-6 3-5 and 3-6 3-13 through 3-16 3-27 and 3-28 3-57 through 3-64 3-67 through 3-74 3-85 through 3-88 3-93 through 3-96 3-99 and 3-104 3-111 through 3-116 3-129 and 3-130 3-133 and 3-134 3-137 through 3-146 3-151 through 3-156 4-1 and 4-2 4-5 through 4-8 4-13 and 4-14 4-19 and 4-20 4-29 and 4-30 4-37 and 4-38 4-43 through 4-46 4-57 and 4-58 4-67 and 4-68

3. File this change sheet in back of the publication for reference purposes.

By Order of the Secretary of the Army:

JOHN A. WICKHAM, JR.
General United States Army
Chief of Staff

Official:

DONALD J. DELANDRO
Brigadier General United States Army
The Adjutant General

Distribution:

To be distributed in accordance with DA Form 12-37, Organizational Maintenance requirements for Vehicle, Combat Engineer, Full Tracked, M728.

Technical Manual
No. 9-2350-222-20-2-2-1

**HEADQUARTERS,
DEPARTMENT OF THE ARMY**
Washington, D.C., 15 September 1980

Technical Manual
Organizational Troubleshooting

TURRET
FOR
COMBAT ENGINEER VEHICLE
M728
(2350-00-795-1797)

REPORTING ERRORS AND RECOMMENDING IMPROVEMENTS

You can help improve this manual. If you find any mistakes or if you know of a way to improve the procedures, please let us know.

Mail your letter, DA Form 2028 (Recommended Changes to Publications and Blank Forms), or DA Form 2028-2 located in the back of this manual directly to:

Commander
U.S. Army Armament Materiel Readiness Command
ATTN: DRSAR-MAS
Rock Island, IL 61299

A reply will be furnished to you.

1 This manual in conjunction with TM 9-2350-222-20-2-1, TM 9-2350-222-20-2-2-2, TM 9-2350-222-20-2-3-1, TM 9-2350-222-20-2-3-2, TM 9-2350-222-20-2-3-3, supersedes the turret portion of TM 9-2350-222-20, September 1965, including all changes.

TABLE OF CONTENTS

	Paragraph	Page
PART 1		
Chapter 1.	INTRODUCTION	1-1
	scope	1-1
	Introduction (Chapter 1)	1-2
	Symptom Indexes (Chapter 2)	1-3
	Fault Isolation Diagrams (Chapter 3 thru 7)	1-4
	Schematics (Foldouts)	1-5
	Equipment Location Information (Foldouts)	1-6
	Troubleshooting Approach	1-7
	Sample Fault Isolation Diagram	1-10
	Component/Assembly Nomenclature	1-14
Chapter 2.	SUMMARY SYMPTOM INDEXES	2-1
Chapter 3.	ARMAMENT FAULT ISOLATION DIAGRAMS	3-1
Chapter 4.	TURRET TRAVERSE AND GUN ELEVATION FAULT ISOLATION "DIAGRAMS"	4-1
Foldouts	EQUIPMENT LOCATION INFORMATION AND SCHEMATICS
PART 2		
Chapter 4 (Cont)
Thru		
Chapter 7
Foldouts

CHAPTER 1

INTRODUCTION

1-1. Scope. This manual contains troubleshooting information pertaining to organizational maintenance of the turret for the Full Tracked Combat Engineer Vehicle M728.

1-2. Introduction (Chapter 1). This chapter describes the troubleshooting approach or method that you should follow to locate faults. It also explains how to use the Fault Isolation Diagrams. For additional information on the use of this manual refer to ETM 643-091 -9400 R/JPG.

1-3. Symptom Indexes (Chapter 2). The Summary Symptom Index and the Fault Symptom index assist you in finding the correct Fault Isolation Diagram for any symptom.

1-4. Fault Isolation Diagrams (Chapter 3 thru 7). Each chapter contains fault isolation diagrams for an equipment area or system. Chapter 1 explains how to use the diagrams.

1-5. Schematics (Foldouts). Schematics supplement the Fault Isolation Diagrams. While you will not need them to perform the Fault Isolation procedures, they can help you to understand how the turret components are connected and how the fault isolation diagrams locate a fault. They also provide supplemental information with which to isolate unusual or very complex faults. These foldouts are located at the back of each part of the manual.

1-6. Equipment Location Information (Foldouts). The equipment location information foldouts show you where the equipment you are troubleshooting is located. These foldouts are located at the back of each part of the manual.

1-7. TROUBLESHOOTING APPROACH

1-8. This section explains the approach you should follow in troubleshooting and fault isolation. Once you understand the troubleshooting approach, you will be able to easily locate faulty system components from fault symptoms.

1-9. To find the cause of an equipment problem, you should perform the following steps.

- a. Step 1 - Identify as many failure symptoms as you can. This will help you isolate the fault to a specific equipment area. Don't forget to make a visual inspection when you are identifying failure symptoms. Many times, the cause of a problem may be as simple as a switch that is in the wrong position or a burned-out lamp that is right in front of you.
- b. Step 2 - Go to the Summary Symptom Index in Chapter 2. The Summary Symptom Index gives page numbers in the Fault Symptom Index where symptoms are found that apply to a faulty subsystem. Find the faulty system or subsystem such as Armament or CBR system in the Summary Symptom Index and note the page number in the page column.
- c. Step 3 - Go to the Fault Symptom Index in Chapter 2. Turn to the page noted in the

Summary Symptom Index and match your symptoms. For each symptom, the fault isolation diagram required to troubleshoot the symptom will be identified.

- d. Step 4- Go to the Fault Isolation Diagram or maintenance manual which was referenced in the Fault Symptom Index and follow the procedure to isolate the faulty component.

1-10. SAMPLE FAULT ISOLATION DIAGRAM

1-11. This section explains how to use the Fault Isolation Diagrams. Once you understand a few easy rules on how to use these diagrams, troubleshooting will be easy.

1-12. A fault isolation diagram is a step-by-step procedure, presented in flow diagram form. It will assist you in finding a faulty component or malfunction that causes the fault symptom. The Fault Isolation Diagrams are located in Chapters 3 thru 7.

1-13. Follow the lettered callouts on the sample fault isolation diagram. Each callout has a lettered note which will explain what the symbol or information on each diagram means. After using the diagrams a few times, you will find that they are really easy to follow and you will be troubleshooting like an experienced turret mechanic.

1-14. Component/Assembly Nomenclature. In parts of this manual, component/assembly nomenclature may differ, Refer to Appendix C, TM-20-2-1, for the component/assembly name used in the Maintenance Allocation Chart and the associated common name used in the maintenance procedures.

3-1. 7.62MM COAX MACHINE GUN TROUBLESHOOTING

SYMPTOM: (1) 7.62MM Coax machine gun fails to fire with gunner's trigger
 (2) 7.62MM Coax machine gun fails to fire with commander's trigger
A → (3) 7.62MM Coax machine gun fails to fire with Manual Elevation Hand Pump trigger
 (4) 7.62MM Coax machine gun fails to fire with any trigger

TEST EQUIPMENT: Multimeter

PERSONNEL: Two

	FOLDOUT	CALLOUT
UNIT LOCATION: Master Control Panel	4	4
Gunner's Control Box	1	2
Gunner's Control Handle	1	19
Commander's Control Handle	2	12
Manual Elevation Hand Pump	1	13
Turret Gun Firin Relay Box	1	22
B → Turret Electrical Slipping	3	5
Turret Power and Searchlight Relay Box	1	9
7.62-MM Coax MG	3	3
Gun Quick Disconnect	1	20
Gunner's Dome Light	1	1

REFERENCES: (1) TM 9-2350 -222-20-2-3 for removal and replacement of components
 (2) ETM 643-091-9400 R/JPG for procedures to:
 Use multimeter
 Disconnect electrical connectors
 (3) TM 9-2350-222-10 for procedure to:
 Remove ammunition

EQUIPMENT CONDITION: Tank parked, power off, gun in travel lock

- A** This is the symptom identified in the Fault Symptom Index in Chapter 2.
- B** The first sheet of each Fault Isolation Diagram will give you information that you will need to know before you can do the procedure. Be sure to read it carefully.

SAMPLE

CALLOUTS	DESCRIPTION
o ^c	Block number. Tells you the number of the block on the page. Block numbers start over at every page.
o ^D	This is a warning. Always follow the instructions in this kind of block carefully. If you don't, you may be injured or injure someone else.
o ^E	This is a caution. The instructions in this kind of block tell you what to do so you will not damage equipment. Be sure you always follow caution instructions carefully.
o ^F	This is a note. It gives useful extra information that can help you in performing the procedure. A note will always come just before the procedure or steps of the procedure that it is about.
o ^G	This number located in the procedure and the circled matching number in the accompanying illustration help you locate the connector, switch, knob, etc. The illustration will always be on the same or a facing page, Remember you will never have to turn the page to locate the illustration.
o ^H	The circle is used when you must go to another area of the procedure to continue troubleshooting. The top number in the circle tells you what sheet to go to. The bottom number tells you what block on that sheet to start with. For example 3.01 means that you should go to sheet 3 block 01 to continue the procedure.

3-1. 7.62 MM COAX MACHINE GUN TROUBLESHOOTING

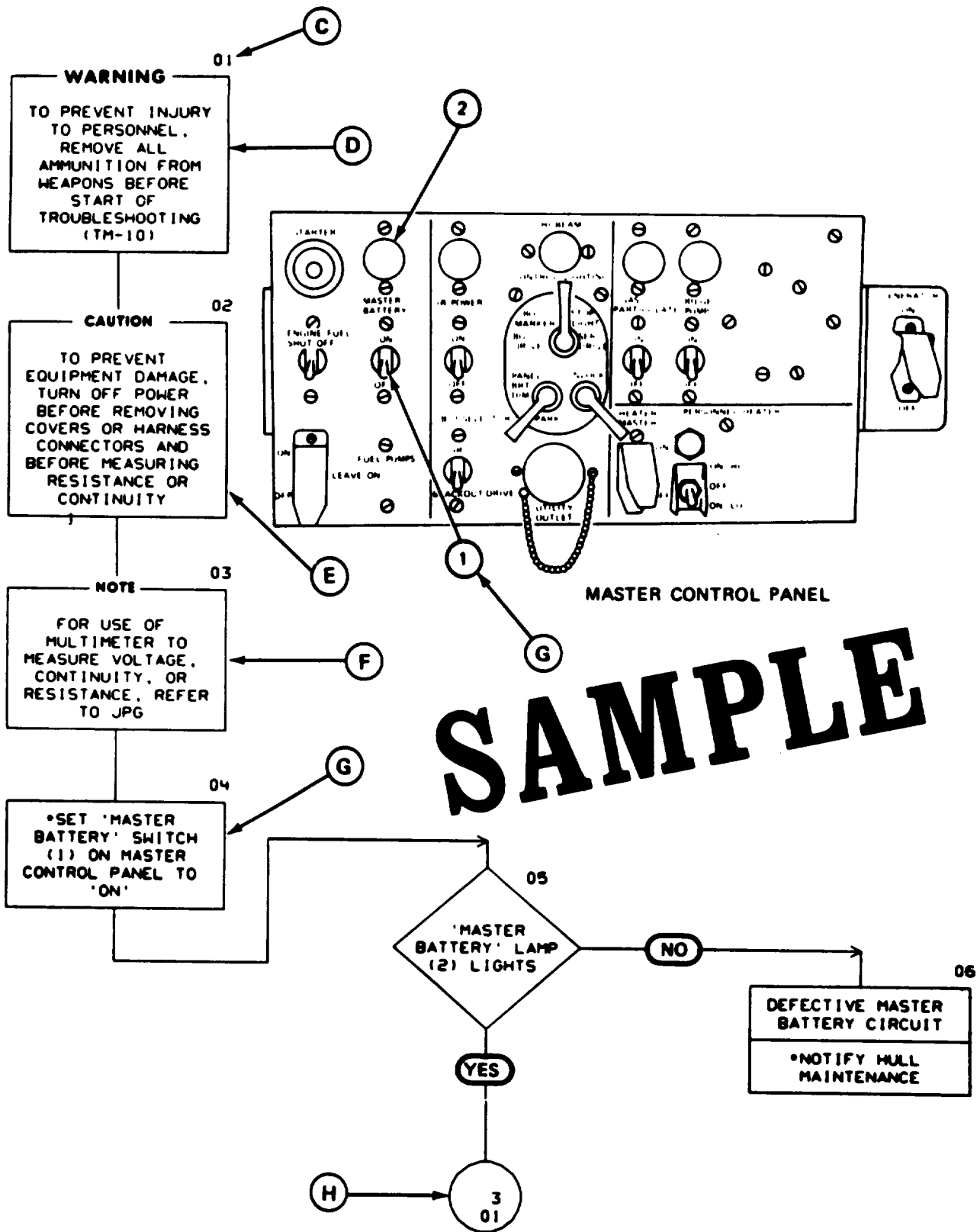

SAMPLE

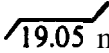
CALLOUTS	DESCRIPTION		
I	This tells you where you came from.		
	Location	Sheet	Block
	14.02	14	02
J	The top part of the box tells you what to do. The bottom part tells you how to do it. After you become more skilled at troubleshooting and more familiar with the equipment, you may find that you only need to read the top part of the box.		
K	This diamond shaped box is called a decision point. It gives you the results you should expect after performing the what to do statement. If the result was right, you continue down the (YES) branch. If the result was wrong, you continue down the (NO) branch.		
L	The symbol  means that you will have to go to another location on the same sheet or a nearby sheet to continue with the procedure. The numbers 19.05 tell you the sheet and block on that sheet where the procedure continues. For example, 19.05 means go to sheet 19 and continue with block 05.		
M	Lower case letters which identify the pins or sockets of harness connectors are preceded by a double dash.		

3-1. 7.62 MM COAX MACHINE GUN TROUBLESHOOTING

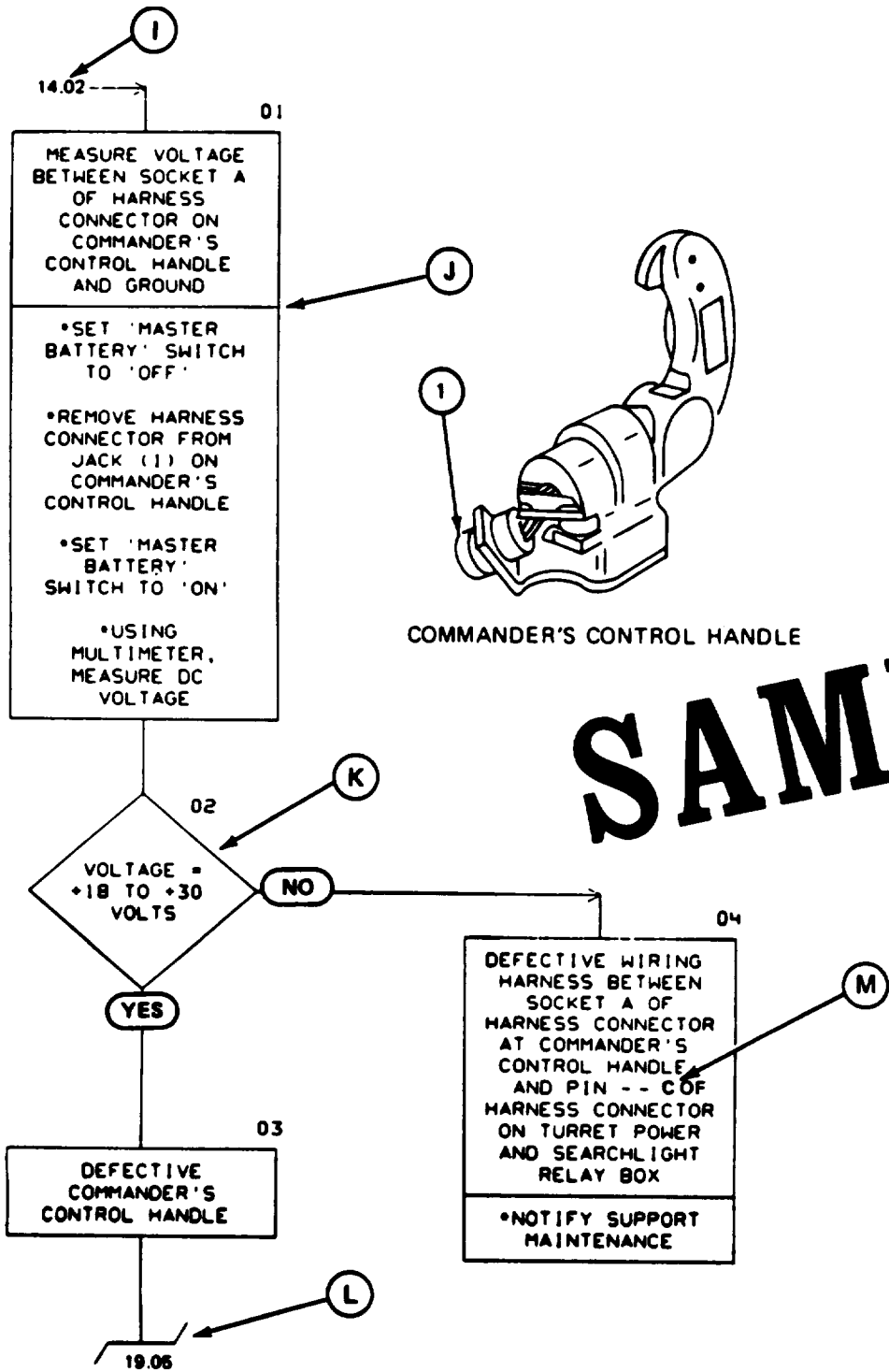

CHAPTER 2

SYMPTOM INDEXES

SUMMARY SYMPTOM INDEX

Subsystem	Symptom Number	Page
7.62MM Coax Machine Gun	1 thru 5	2-2
Caliber .50 Machine Gun	6, 7	2-2
Main Gun	8 thru 13	2-2
Blasting Machine	14	2-3
Traverse	15 thru 24	2-3
Elevation	25 thru 29	2-3,24
Winch and Boom	30, 31	2-4
Deck Clearance	32, 33	2-4
Azimuth Indicator	34, 35	2-4
Elevation Quadrant	36, 37	2-4
Commander's Periscope	40 thru 45	2-4
Gunner's Periscope	46 thru 49	2-5
Heaters	50 thru 52	2-5
Vent Blower	53, 54	2-5
Dome Lights	55 thru 57	2-5
Searchlight (AN/VSS- 1)	58 thru 64	2-5

FAULT SYMPTOM INDEX

Subsystem	Number	Symptom Name	Fault Isolation Diagram (para)
ARMAMENT			
7.62MM Coax Machine Gun	1	7.62MM coax machine gun fails to fire with gunner's trigger	3-1
	2	7.62MM coax machine gun fails to fire with commander's trigger	3-1
	3	7.62MM coax machine gun fails to fire with Manual Elevation Hand Pump	3-1
	4	7.62MM machine gun fails to fire with any trigger	3-1
	5	MACHINE GUN lamp on Gunner's Control Box fails to light	3-5
Caliber .50 Machine Gun	6	Caliber .50 machine gun fails to fire	3-2
	7	Caliber .50 machine gun fails to fire (last round stop installed)	3-6
Main Gun	8	Main gun fails to fire with gunner's trigger	3-3
	9	Main gun fails to fire with commander's trigger	3-3
	10	Main gun fails to fire with trigger on Manual Elevation Hand Pump	3-3
	11	Main gun fails to fire with any trigger	3-3
	12	Firing pulse is longer than 0.5 seconds	3-3
	13	MAIN GUN lamp on Gunner's Control Box fails to light	3-5

Subsystem	Number	Symptom Name	Fault Isolation Diagram (para)
Blasting Machine	14	Blasting Machine fails to fire main gun	3-4
		TURRET	
Traverse	15	Electric Drive (DC) Motor fails to run	4-1, 4-2
	16	Electric Drive (DC) Motor makes excessive noise	4-1, 4-2
	17	Electric Drive (DC) Motor runs continuously	4-1, 4-2
	18	Incorrect accumulator gage pressure	4-1, 4-2
	19	Turret fails to traverse smoothly with Manual Traverse Handle	4-1
	20	Turret fails to traverse with Gunner's Handle	4-1
	21	Turret fails to traverse with Commander's Handle	4-1
	22	Turret creeps or traverses without palm switch pressed	4-1
	23	Turret oscillates or drives erratically	4-1
	24	Elevation and traverse power lamp fails to light	4-4
Elevation	25	Main gun fails to elevate/depress smoothly with Manual Elevation Hand Pump	4-2

Subsystem	Number	Symptom Name	Fault Isolation Diagram (para)
	26	Main gun fails to elevate/depress with Gunner's Handle	4-2
	27	Main gun fails to elevate/depress with Commander's Handle	4-2
	28	Main gun creeps or elevates/depresses without palm switch pressed	4-2
	29	Main gun oscillates on drives erratically	4-2
Winch and Boom	30	Winch fails to operate properly	4-3
	a.	Winch cable fails to pay-out	
	b.	Winch fails to lift load (reel-in)	
	c.	Winch fails to hold in raised position (under load)	
	d.	Winch fails to lower load slowly	
	31	Boom fails to operate properly	4-3
	a.	Boom fails to erect	
	b.	Boom fails to stow	
Deck Clearance	32	Deck clearance fails to operate	4-5
	33	Deck clearance fails to operate within proper limits	4-5
FIRE CONTROL			
Azimuth Indicator	34	Azimuth Indicator lamps fail to light (M28E2)	5-1
	35	Azimuth Indicator lamps fail to dim (M28E2)	5-1
Elevation Quadrant	36	Elevation Quadrant light source fails to light	5-2

Subsystem	Number	Symptom Name	Fault Isolation Diagram (para)
	37	Elevation Quadrant light source fails to dim	5-2
Telescope Light Source Control	38	Telescope Light Source Control fails to light	5-2
	39	Telescope Light Source Controls fails to dim	5-2
Commander's Periscope	40	Daylight reticle fails to light	5-3
	41	IR/Passive reticle fails to light	5-3
	42	No IR/Passive image	5-3
	43	Daylight reticle fails to light (commander's control panel installed)	5-5
	44	IR/Passive reticle fails to light (Commander's control panel installed)	5-5
	45	NO IR/Passive image (commander's control panel installed)	5-5
Gunner's Periscope	46	Daylight reticle fails to light	5-4
	47	Infinity sight reticle fails to light	5-4
	48	IR/Passive reticle fails to light	5-4
	49	No IR/Passive image	5-4
Heaters	50	Commander's air filter heater fails to operate	6-1
	51	Loader's air filter heater fails to operate	6-2
	52	Gunner's air filter heater fails to operate	6-2

Subsystem	Number	Symptom Name	Fault Isolation Diagram (para)
Vent Blower	53	Vent Blower fails to operate	6-3
	54	Utility outlet fails to operate	6-3
LIGHTING			
Dome Lights	55	Red Dome Light fails to light	7-1
	56	White Dome Light fails to light	7-1
	57	Red or white Dome Light fails to dim	7-1
Searchlight (AN/VSS-1)	58	Xenon lamp fails to light	7-2
	59	Indicator lamp fails to light	7-2
	60	Beam width does not change	7-2
	61	IR filter fails to operate (mode of operation does not change)	7-2
	62	Searchlight shutter fails to operate	7-2
	63	Overdrive fails to operate	7-2
	64	Blower motor fails to run	7-2
	65	Xenon lamp fails to light	7-3
SMOKE GRENADE LAUNCHER			
Smoke Grenade Launcher	66	Grenade launcher fails to fire	7-4
	67	Grenade POWER lamp fails to light	7-4

CHAPTER 3

ARMAMENT FAULT ISOLATION DIAGRAMS

3-1. 7.62MM COAX MACHINE GUN TROUBLESHOOTING (SHEET 1 OF 28)

SYMPTOM: (1) 7.62MM Coax machine gun fails to fire with gunner's trigger
 (2) 7.62MM Coax machine gun fails to fire with commander's trigger
 (3) 7.62MM Coax machine gun fails to fire with trigger on Manual Elevation Hand Pump
 (4) 7.62MM Coax machine gun fails to fire with any trigger

TEST EQUIPMENT Multimeter

PERSONNEL Two

	FOLDOUT	CALLOUT
UNIT LOCATION: Master Control Panel	4	4
Gunner's Control Box	1	2
Gunner's Control Handle	1	19
Commander's Control Handle	2	12
Manual Elevation Hand Pump	1	13
Turret Gun Firing Relay Box	1	22
Electrical Turret Slipping	3	5
Turret Power and Searchlight Relay Box	1	9
7.62MM Coax MG	3	3
Gun Quick Disconnect	1	20
Gunner's Dome Light	1	1

REFERENCES: (1) TM 9-2350-222-20-2-3 for removal and replacement of components
 (2) ETM 643-091-9400 R/JPG for procedures to:
 Use multimeter
 Disconnect electrical connectors
 (3) TM 9-2350-222-10 for procedure to:
 Remove ammunition

EQUIPMENT CONDITION: Vehicle parked, power off
 7.62MM Coax machine gun mounted in tank

3-1. 7.62MM COAX MACHINE GUN TROUBLESHOOTING (SHEET 2 OF 28)

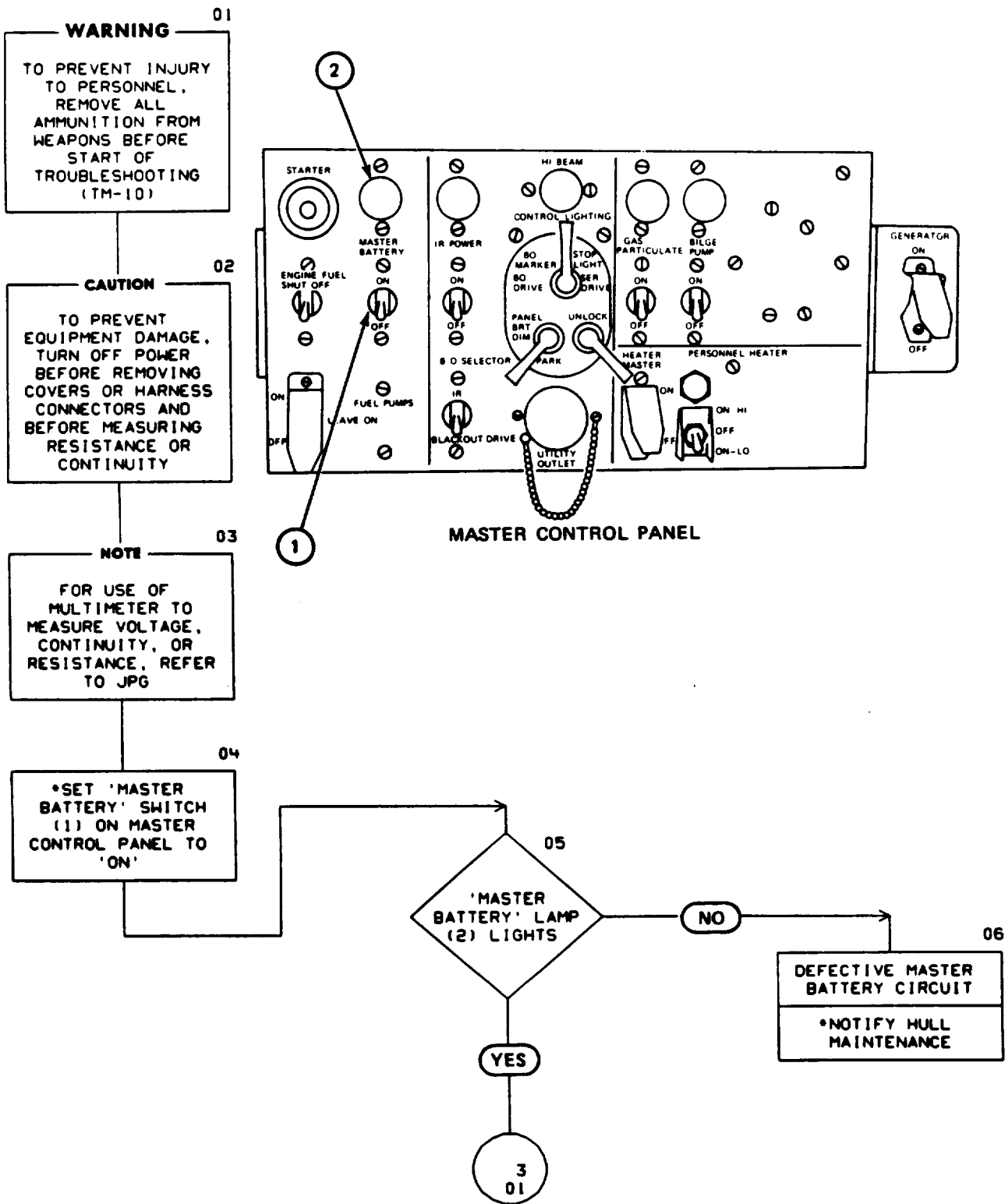

3-1. 7.62MM COAX MACHINE GUN TROUBLESHOOTING (SHEET 3 OF 28)

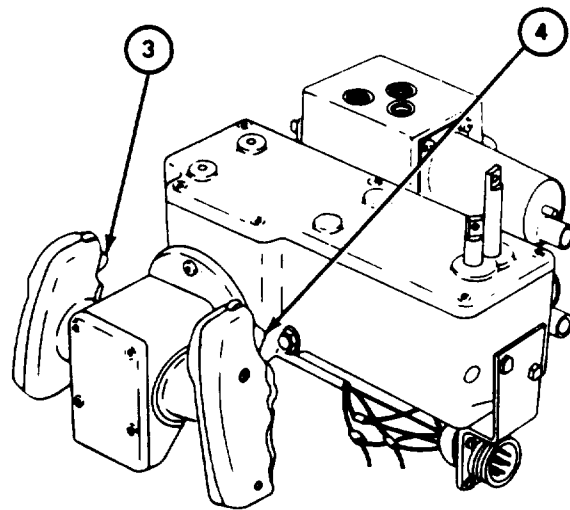
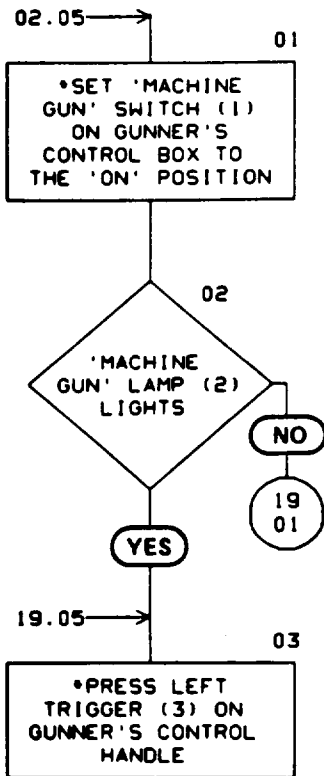

GUNNER'S CONTROL ASSEMBLY

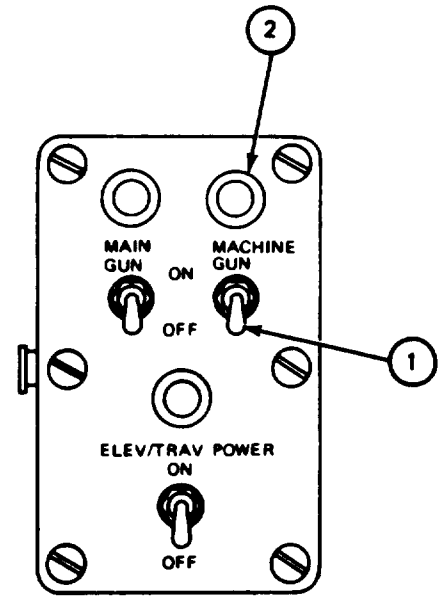
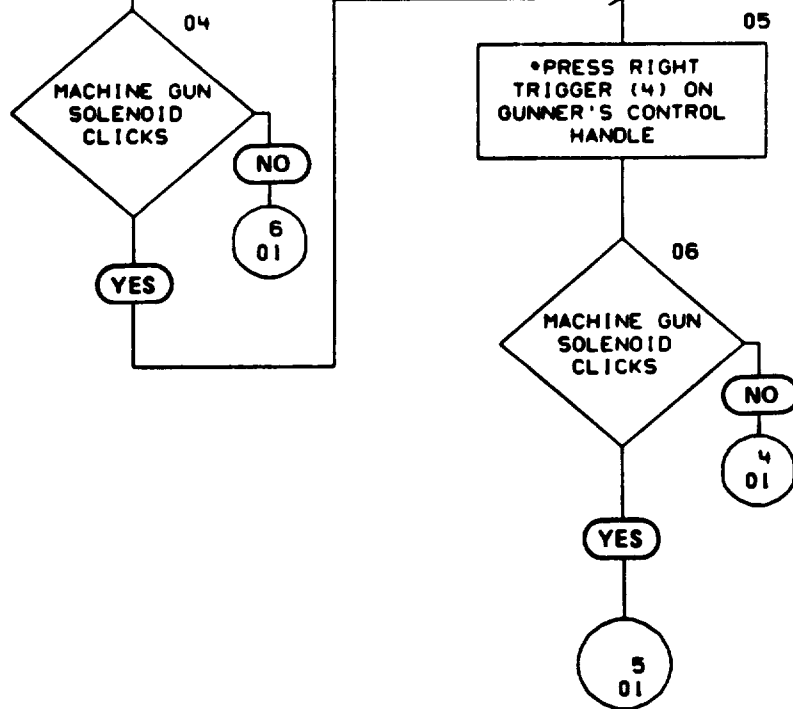

GUNNER'S CONTROL BOX

3-1. 7.62MM COAX MACHINE GUN TROUBLESHOOTING (SHEET 4 OF 28)

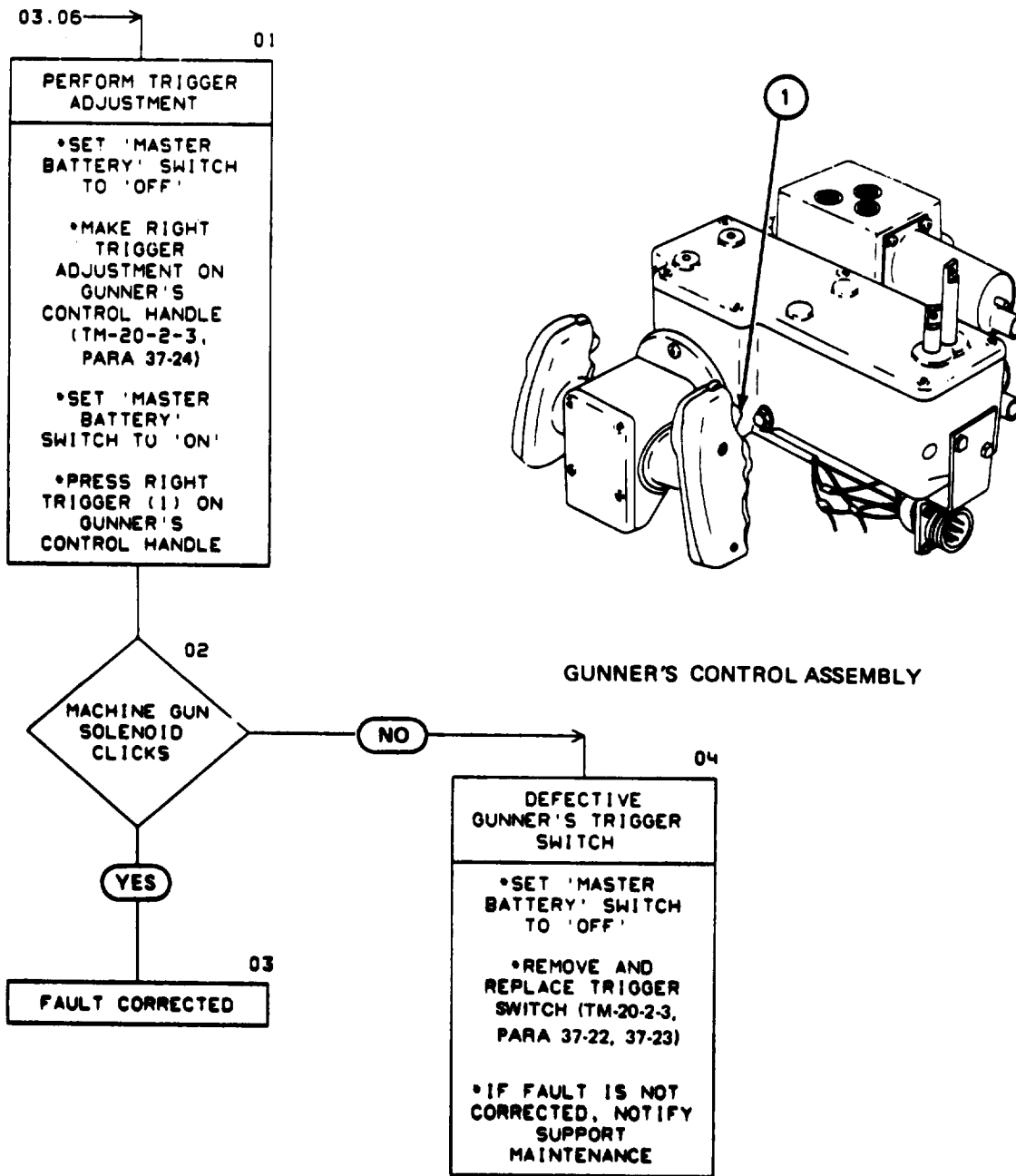

3-1. 7.62MM COAX MACHINE GUN TROUBLESHOOTING (SHEET 5 OF 28)

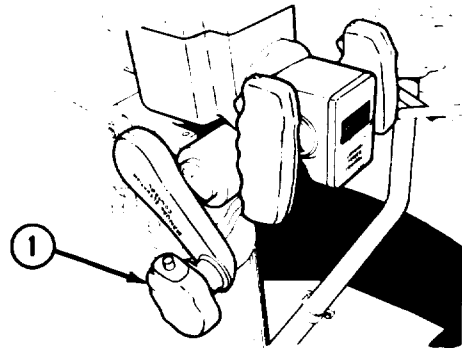
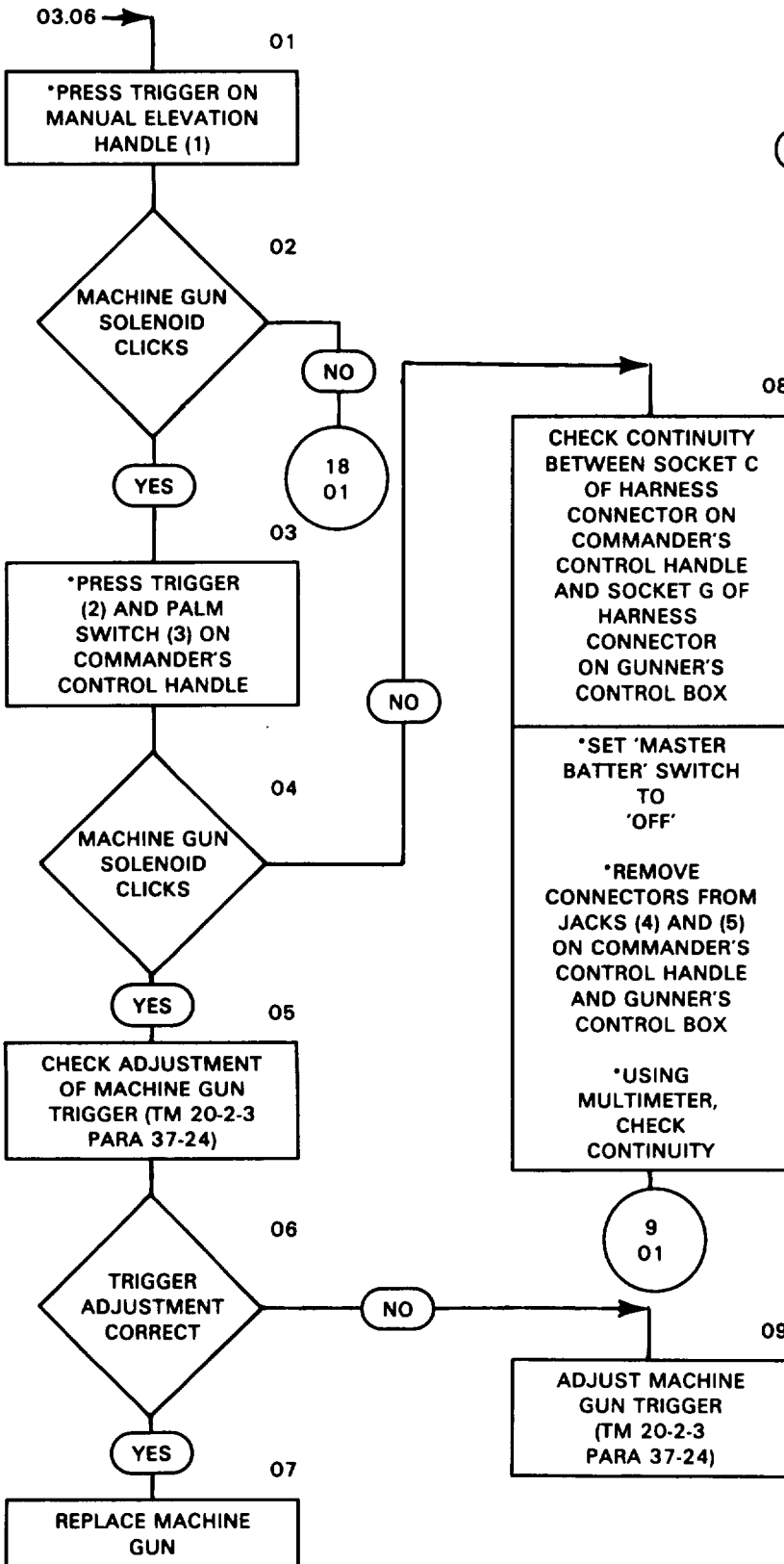

MANUAL ELEVATION PUMP HANDLE

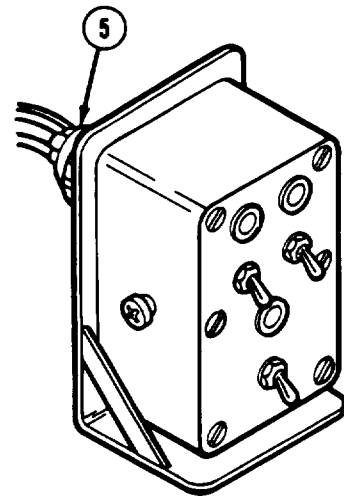

GUNNER'S CONTROL BOX

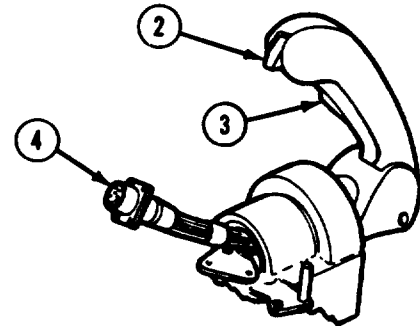

COMMANDER'S CONTROL HANDLE

3-1. 7.62MM COAX MACHINE GUN TROUBLESHOOTING (SHEET 6 OF 28)

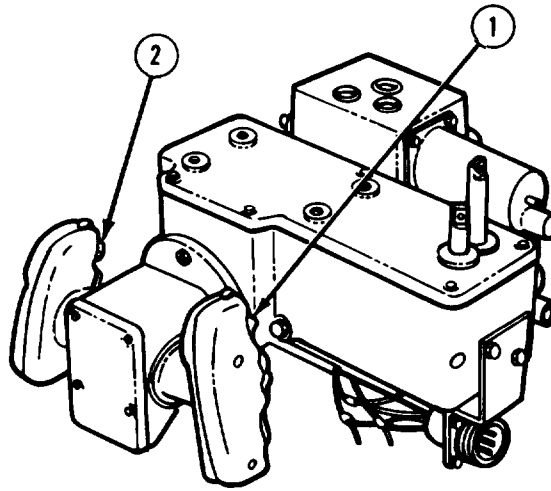
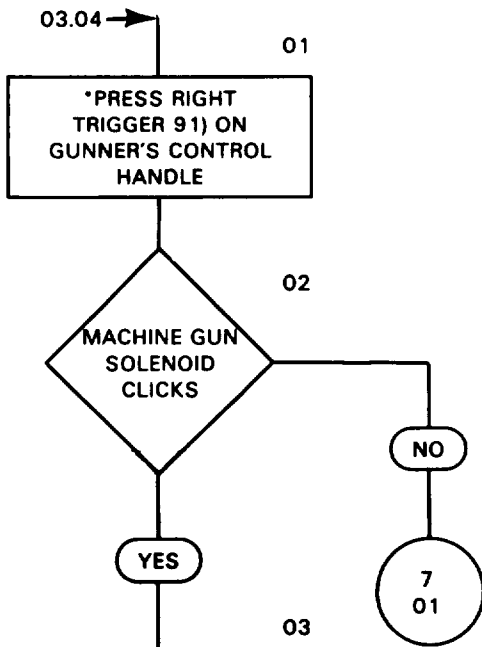

GUNNER'S CONTROL ASSEMBLY

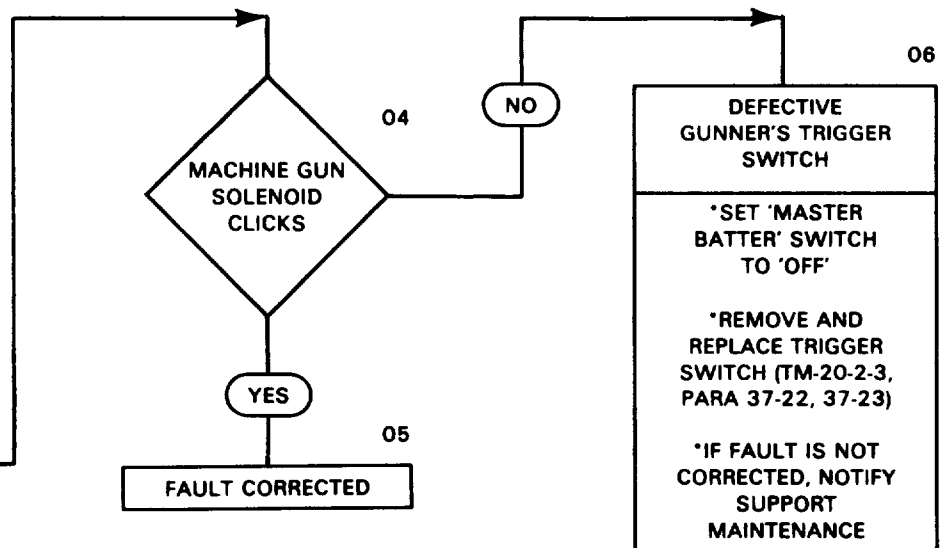
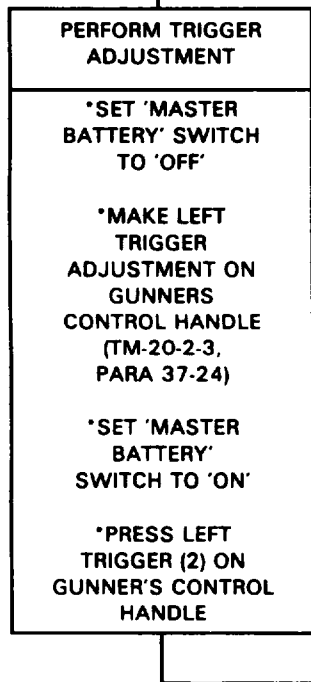

3-1. 7.62MM COAX MACHINE GUN TROUBLESHOOTING (SHEET 7 OF 28)

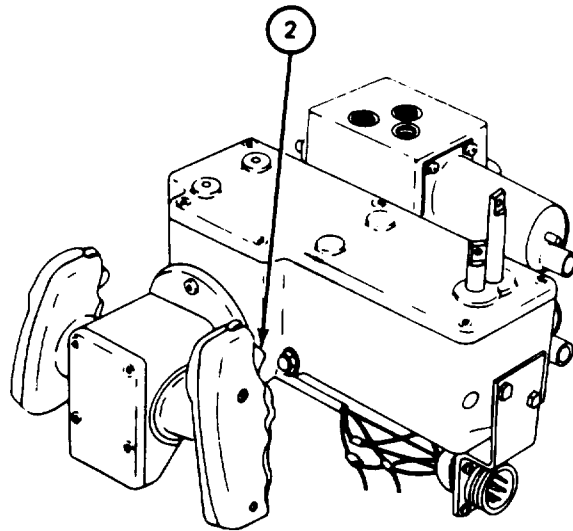
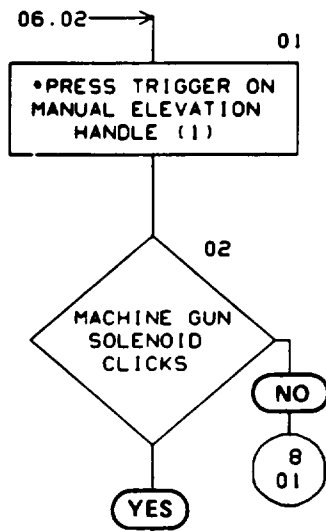

GUNNER'S CONTROL ASSEMBLY

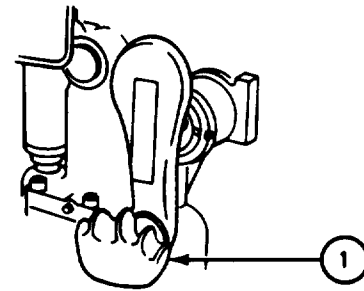
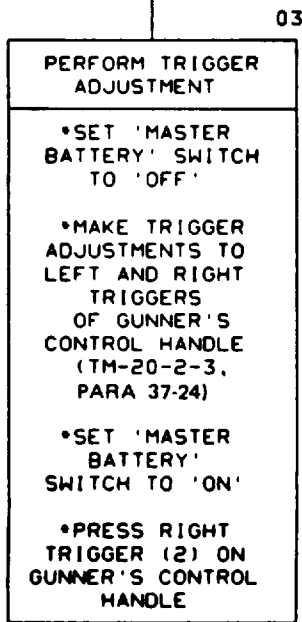

MANUAL ELEVATION PUMP HANDLE

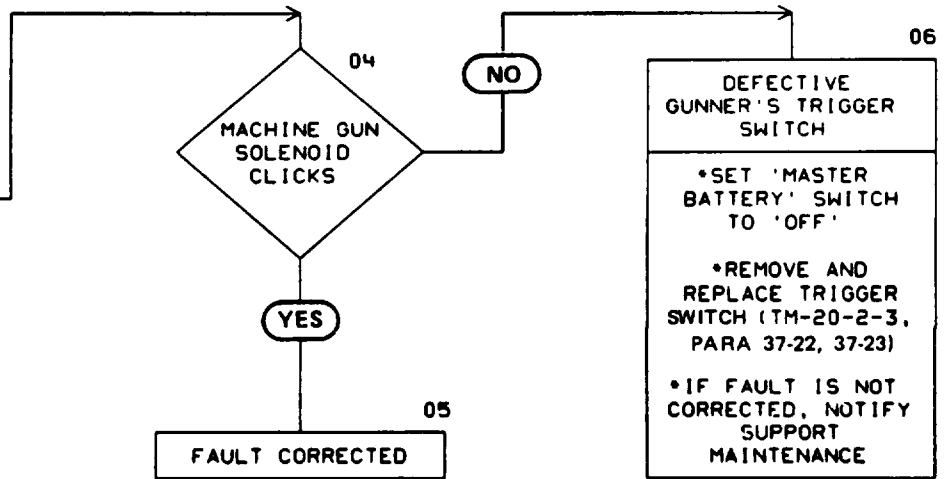

3-1. 7.62MM COAX MACHINE GUN TROUBLESHOOTING (SHEET 8 OF 28)

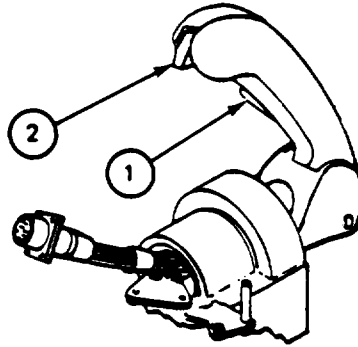
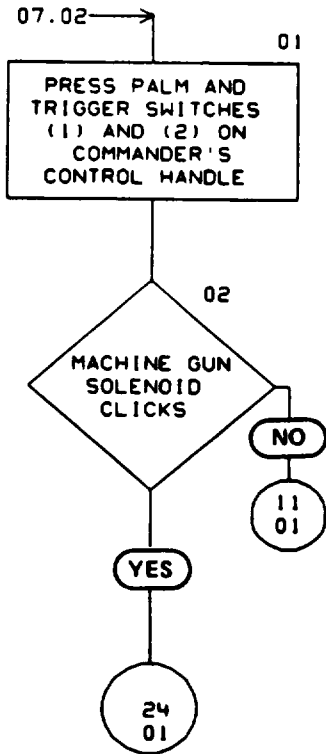

COMMANDER'S CONTROL HANDLE

3-1. 7.62MM COAX MACHINE GUN TROUBLESHOOTING (SHEET 9 OF 28)

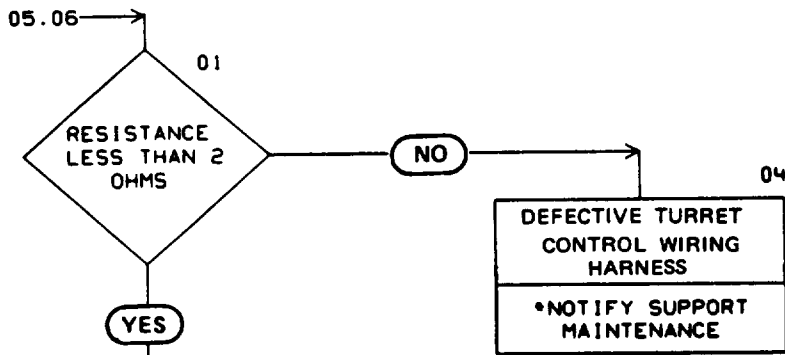

02

CHECK CONTINUITY
BETWEEN SOCKETS G
AND E OF HARNESS
CONNECTOR ON JACK (1)
AT
COMMANDER'S CONTROL HANDLE

*REPLACE HARNESS
CONNECTOR (2) ON
GUNNER'S CONTROL
BOX

*USING
MULTIMETER, CHECK
CONTINUITY

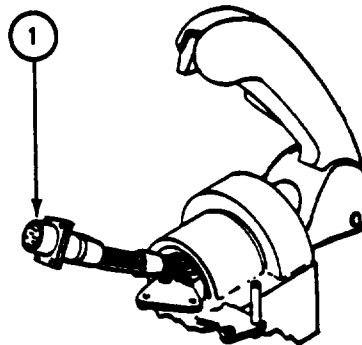

COMMANDER'S CONTROL HANDLE

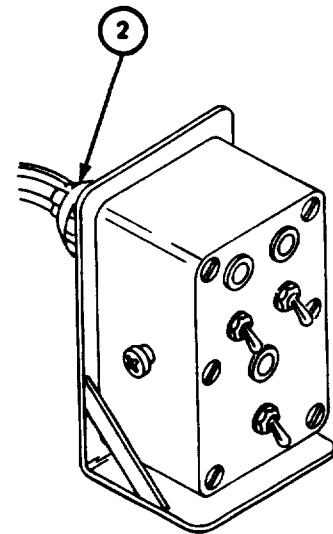
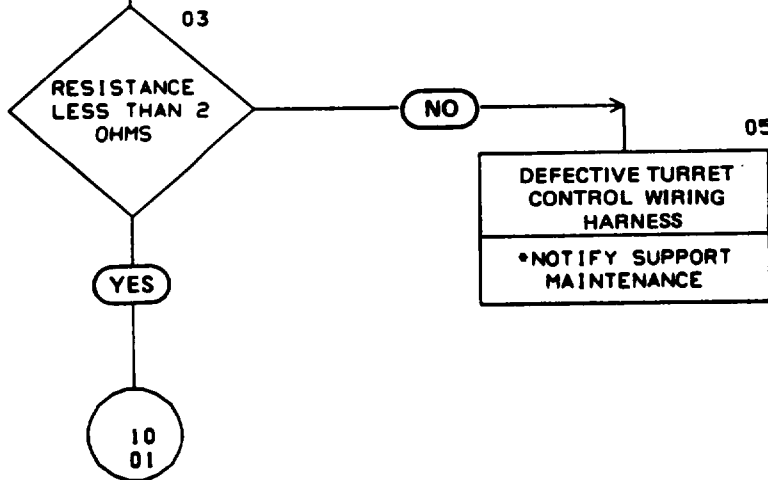

GUNNER'S CONTROL BOX

3-1. 7.62MM COAX MACHINE GUN TROUBLESHOOTING (SHEET 10 OF 28)

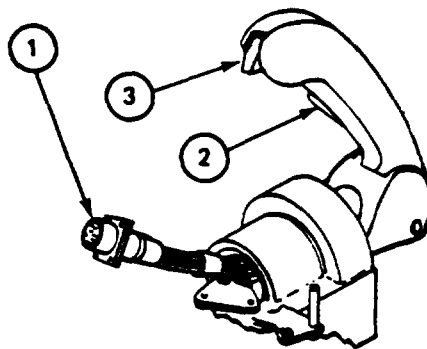
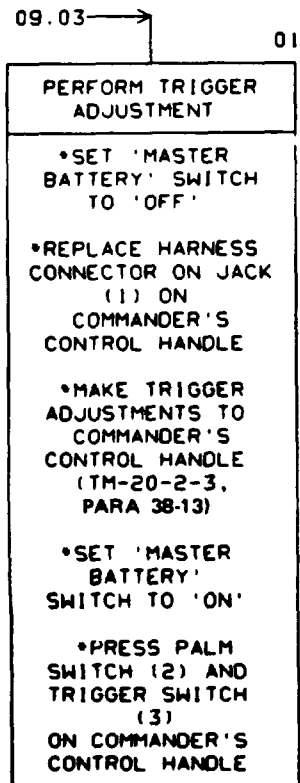

COMMANDER'S CONTROL HANDLE

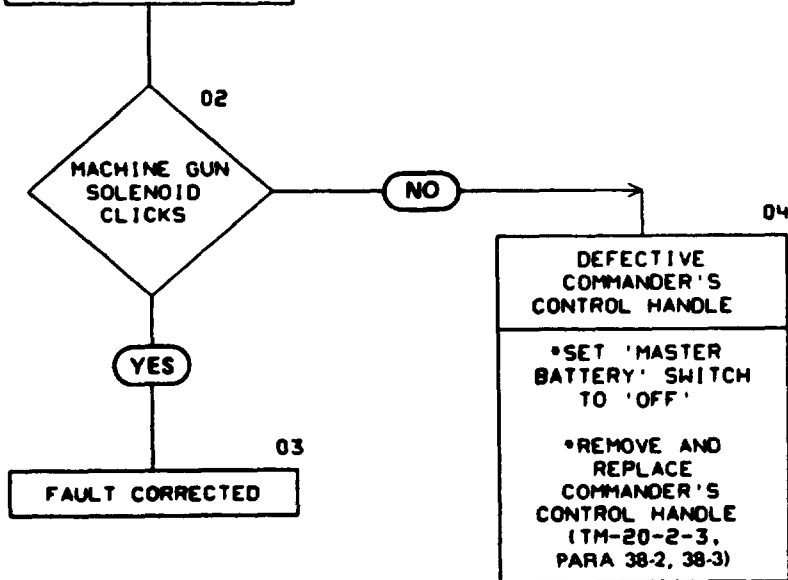

3-1. 7.62MM COAX MACHINE GUN TROUBLESHOOTING (SHEET 11 OF 28)

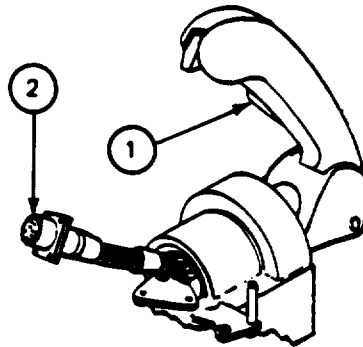
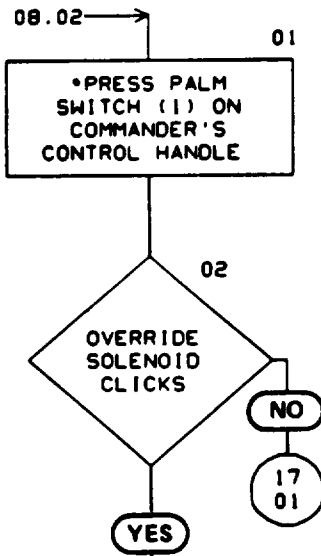

COMMANDER'S CONTROL HANDLE

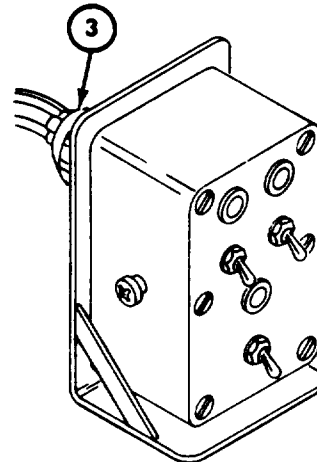
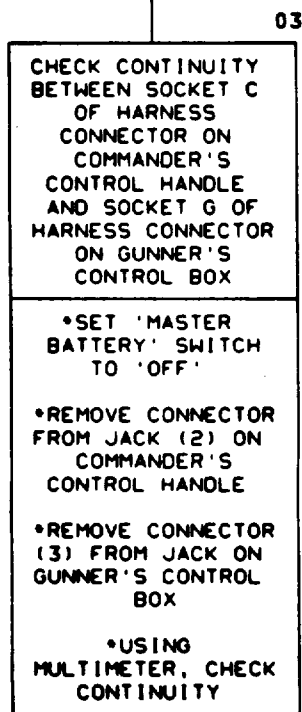

GUNNER'S CONTROL BOX

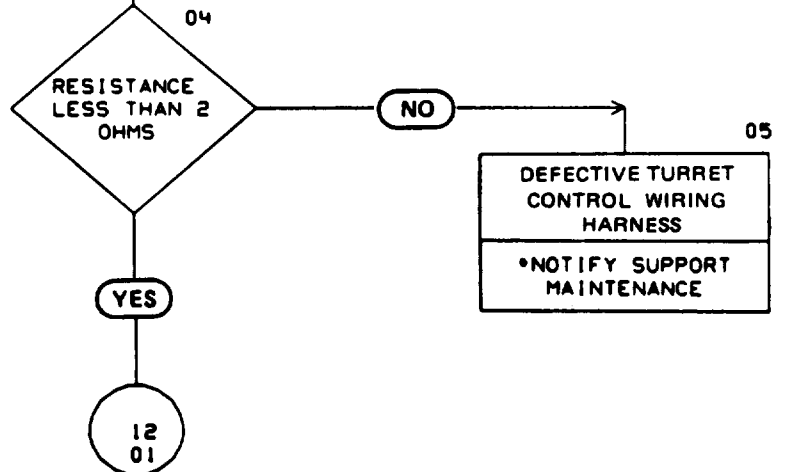

3-1. 7.62MM COAX MACHINE GUN TROUBLESHOOTING (SHEET 12 OF 28)

11.04 →

01

CHECK CONTINUITY BETWEEN SOCKET B OF HARNESS CONNECTOR (1) AT GUNNER'S CONTROL BOX AND SOCKET E OF HARNESS CONNECTOR ON TURRET GUN FIRING RELAY BOX

• REMOVE HARNESS CONNECTOR FROM JACK (2) ON TURRET GUN FIRING RELAY BOX

• USING MULTIMETER, CHECK CONTINUITY

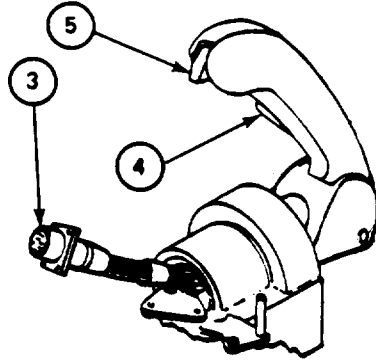

COMMANDER'S CONTROL HANDLE

12.03 →

NOTE 05

CONTINUED FROM A PRIOR COLUMN

CONTROL HANDLE AND HARNESS CONNECTOR (1) ON JACK ON GUNNER'S CONTROL BOX

• SET 'MASTER BATTERY' SWITCH TO 'ON'

• PRESS PALM AND TRIGGER SWITCHES (4) AND (5) ON COMMANDER'S CONTROL HANDLE

• USING MULTIMETER, MEASURE DC VOLTAGE

13
01

02

RESISTANCE LESS THAN 2 OHMS

NO

YES

04

DEFECTIVE TURRET CONTROL WIRING HARNESS

• NOTIFY SUPPORT MAINTENANCE

03

MEASURE VOLTAGE BETWEEN SOCKET E OF HARNESS CONNECTOR AT TURRET GUN FIRING RELAY BOX AND GROUND

• REPLACE HARNESS CONNECTOR ON JACK (3) ON COMMANDER'S

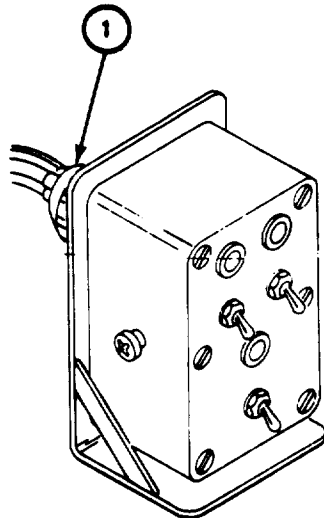

GUNNER'S CONTROL BOX

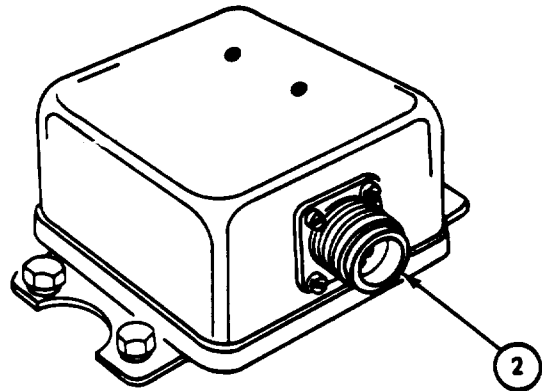

TURRET GUN FIRING RELAY BOX

12.09

3-1. 7.62MM COAX MACHINE GUN TROUBLESHOOTING (SHEET 13 OF 28)

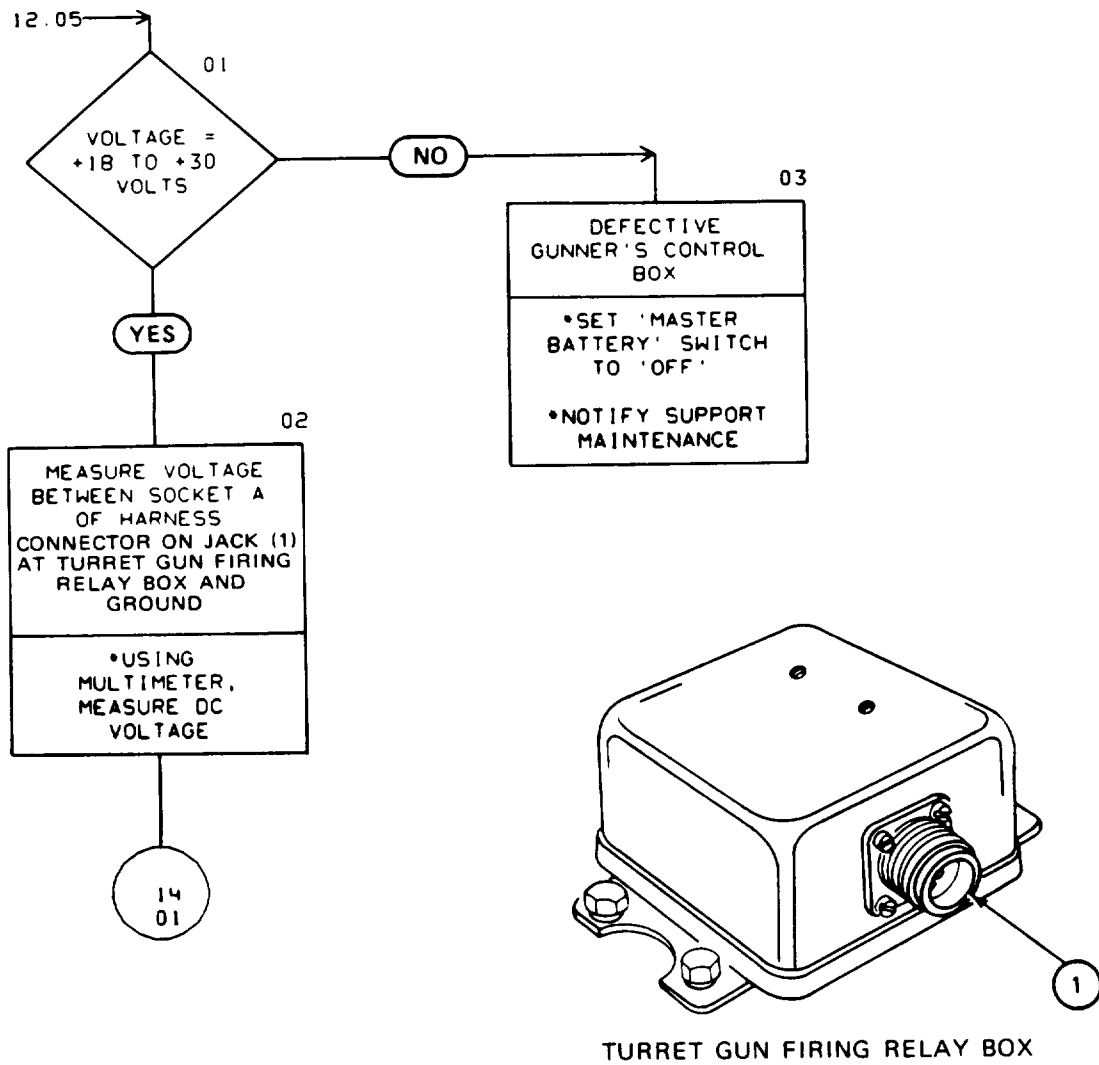

3-1. 7.62MM COAX MACHINE GUN TROUBLESHOOTING (SHEET 14 OF 28)

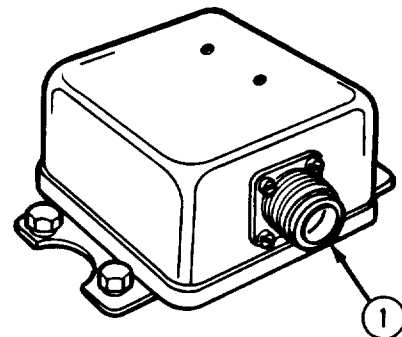
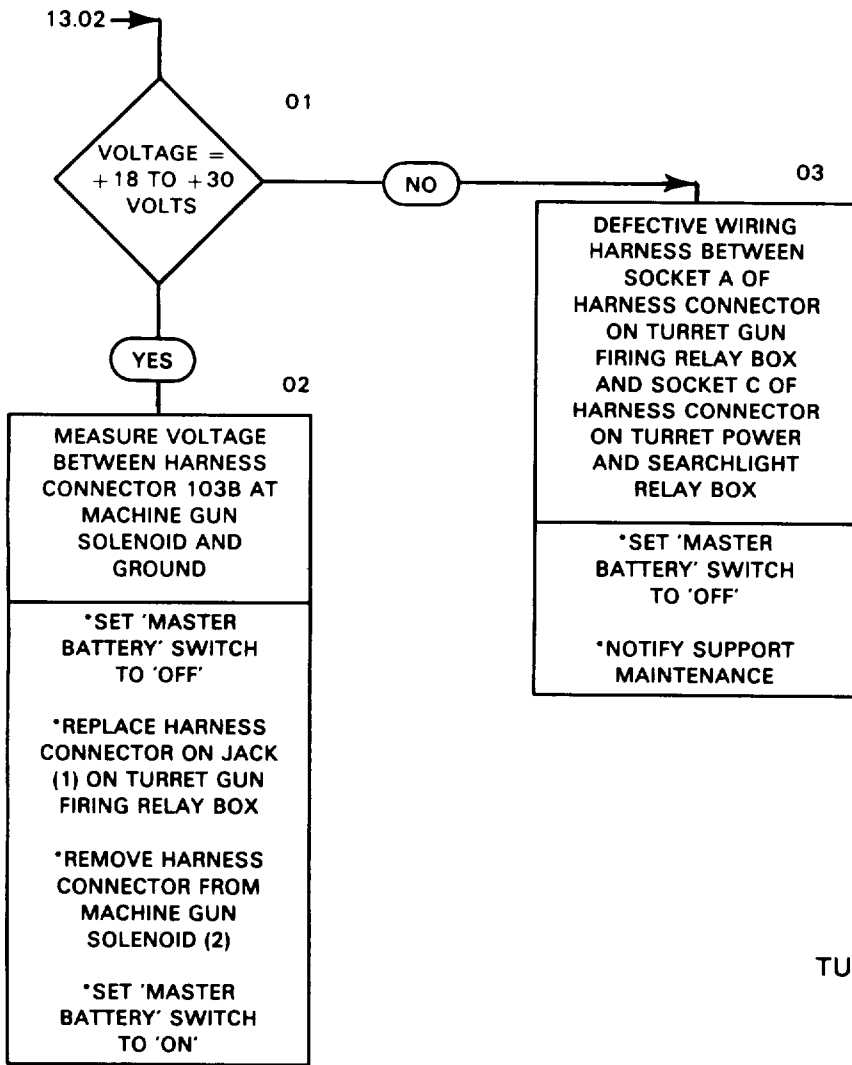

TURRET GUN FIRING RELAY BOX

15
01

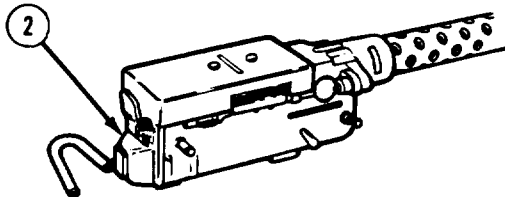

7.62MM COAX MACHINE GUN (M73)

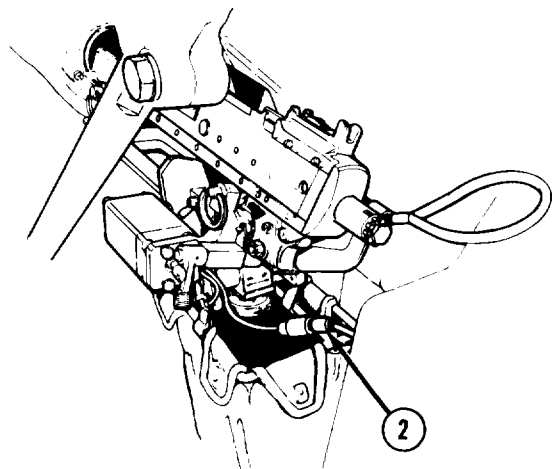

7.62MM COAX MACHINE GUN (M240)

3-1. 7.62MM COAX MACHINE GUN TROUBLESHOOTING (SHEET 15 OF 28)

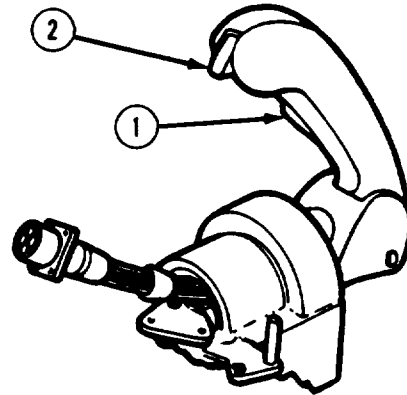
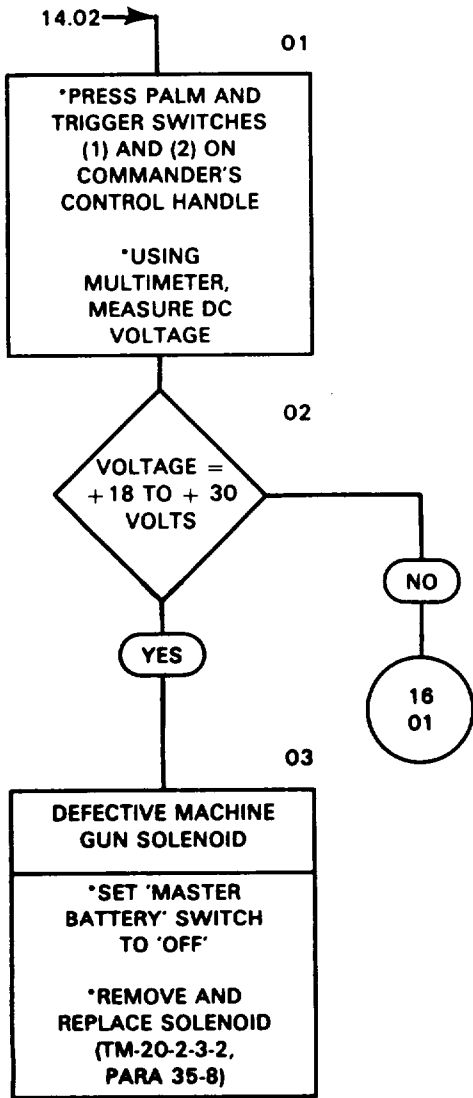

COMMANDER'S CONTROL HANDLE

3-1. 7.62MM COAX MACHINE GUN TROUBLESHOOTING (SHEET 16 OF 28)

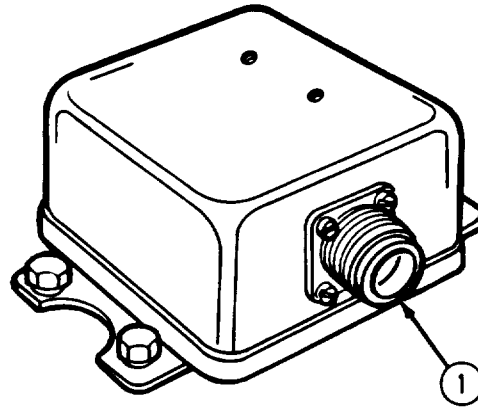
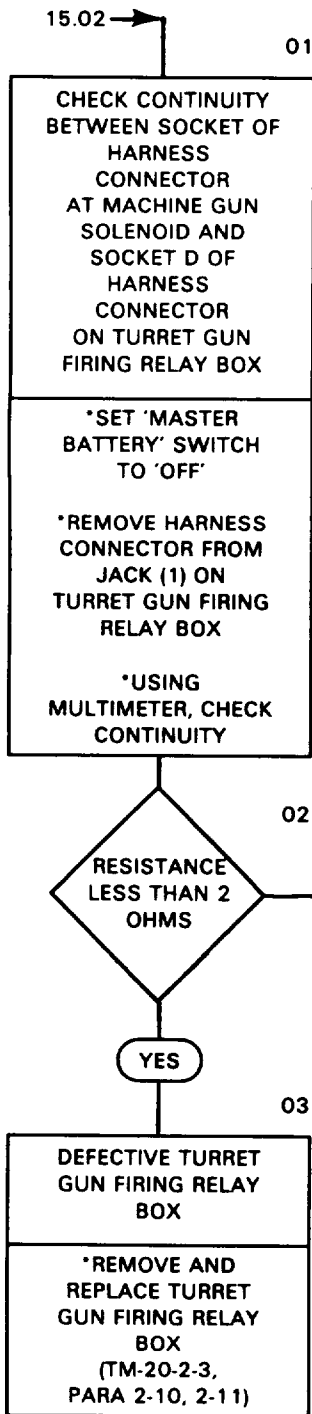

TURRET GUN FIRING RELAY BOX

3-1. 7.62MM COAX MACHINE GUN TROUBLESHOOTING (SHEET 17 OF 28)

11.02 →

01

MEASURE VOLTAGE BETWEEN SOCKET A OF HARNESS CONNECTOR ON COMMANDER'S CONTROL HANDLE AND GROUND

- SET 'MASTER BATTERY' SWITCH TO 'OFF'
- REMOVE HARNESS CONNECTOR FROM JACK (1) ON COMMANDER'S CONTROL HANDLE
- SET 'MASTER BATTERY' SWITCH TO 'ON'
- USING MULTIMETER, MEASURE DC VOLTAGE

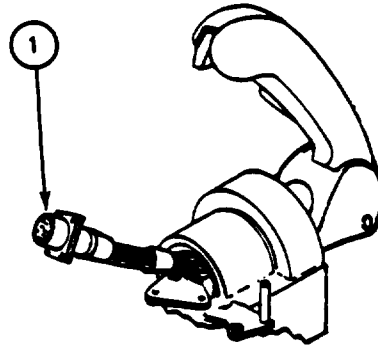

COMMANDER'S CONTROL HANDLE

17.03 →

NOTE 05

CONTINUED FROM A PRIOR COLUMN

- SET 'MASTER BATTERY' SWITCH TO 'OFF'
- REMOVE AND REPLACE COMMANDER'S CONTROL HANDLE (TM-20-2-3, PARA 38-2, 38-3)

02

VOLTAGE = +18 TO +30 VOLTS

YES

03

DEFECTIVE COMMANDER'S CONTROL HANDLE

17.05

NO

04

DEFECTIVE TURRET CONTROL WIRING HARNESS BETWEEN SOCKET A OF HARNESS CONNECTOR AT COMMANDER'S CONTROL HANDLE AND PIN C OF HARNESS CONNECTOR ON TURRET POWER AND SEARCHLIGHT RELAY BOX

- NOTIFY SUPPORT MAINTENANCE

3-1. 7.62MM COAX MACHINE GUN TROUBLESHOOTING (SHEET 18 OF 28)

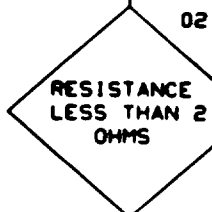
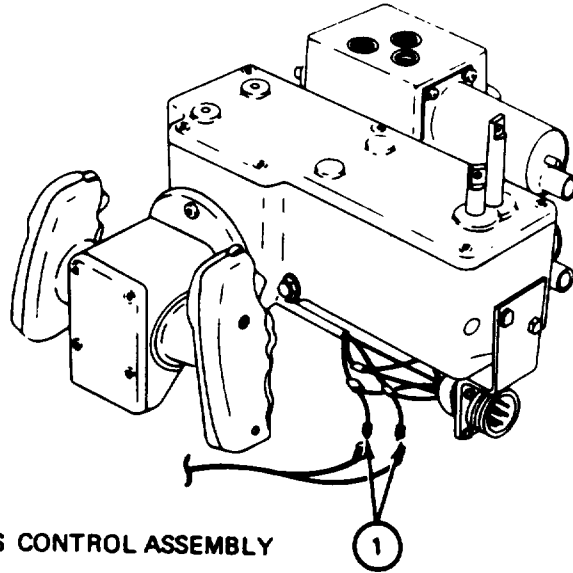
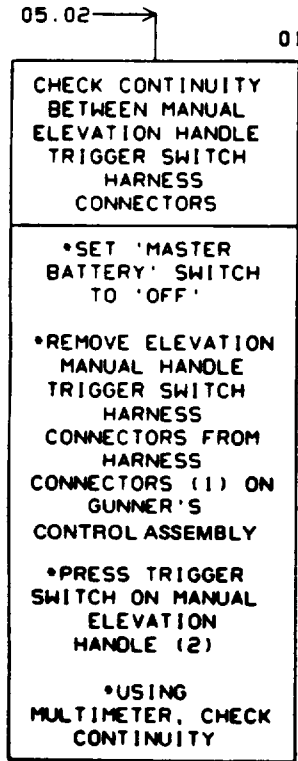

NO

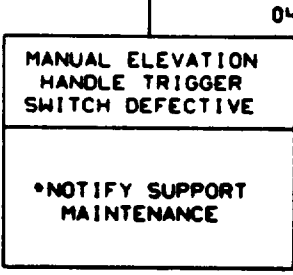

YES

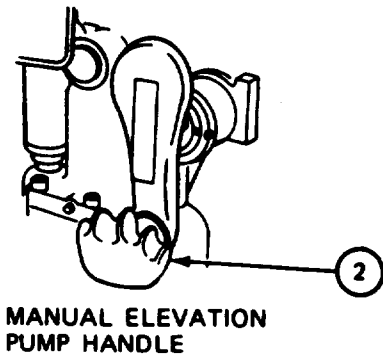
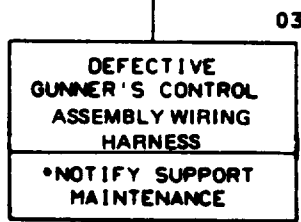

3-1. 7.62MM COAX MACHINE GUN TROUBLESHOOTING (SHEET 19 OF 28)

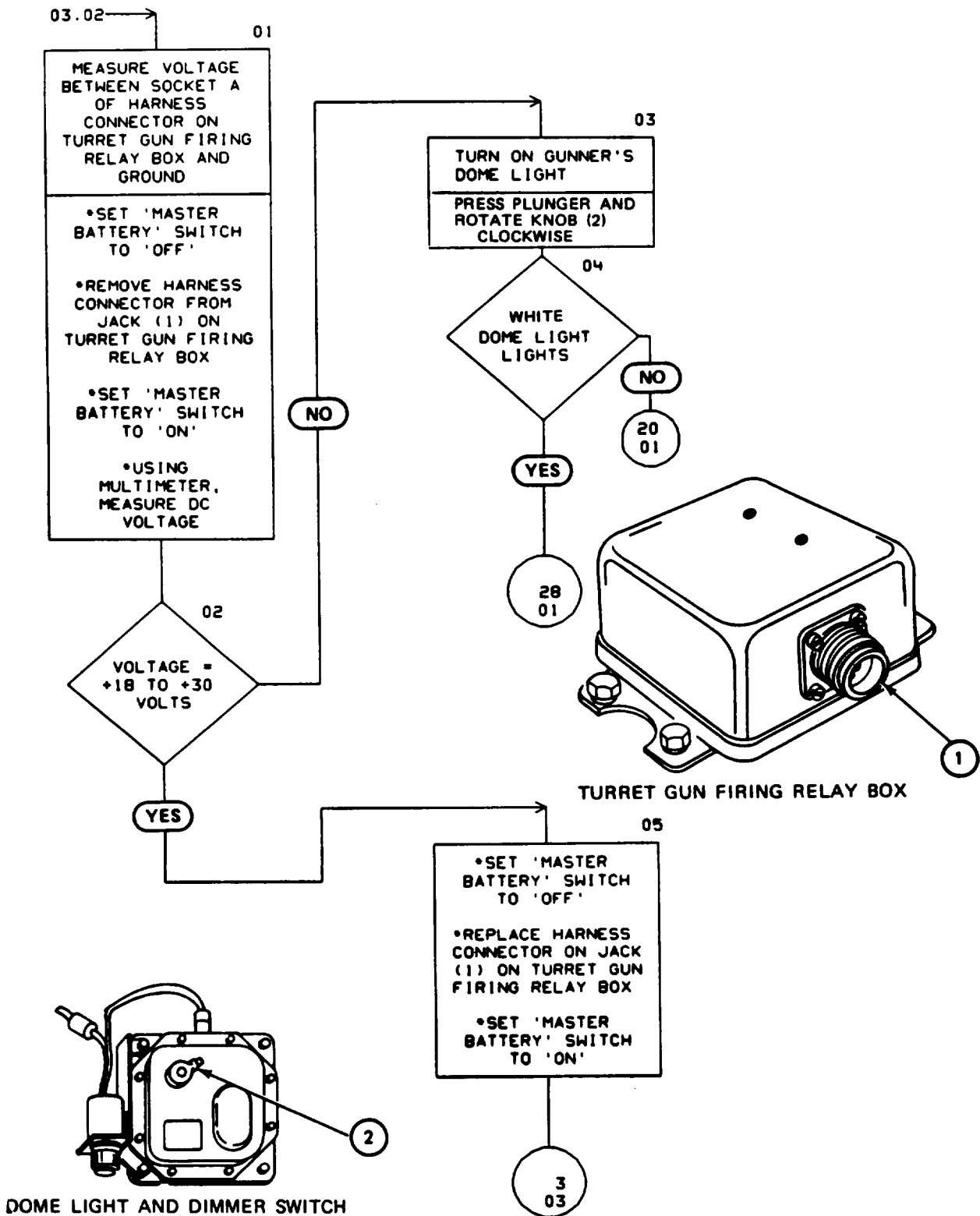

3-1. 7.62MM COAX MACHINE GUN TROUBLESHOOTING (SHEET 20 OF 28)

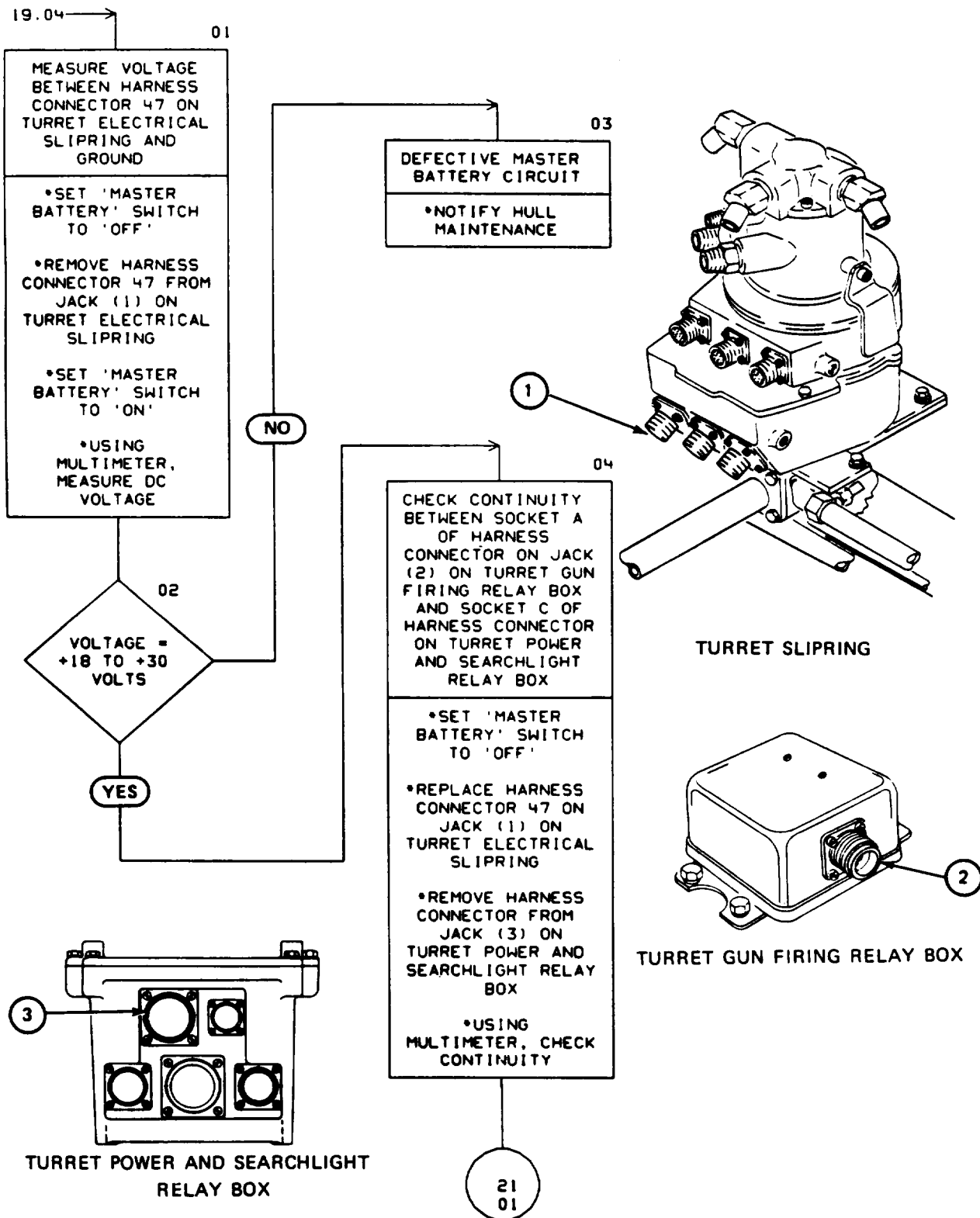

3-1. 7.62MM COAX MACHINE GUN TROUBLESHOOTING (SHEET 21 OF 28)

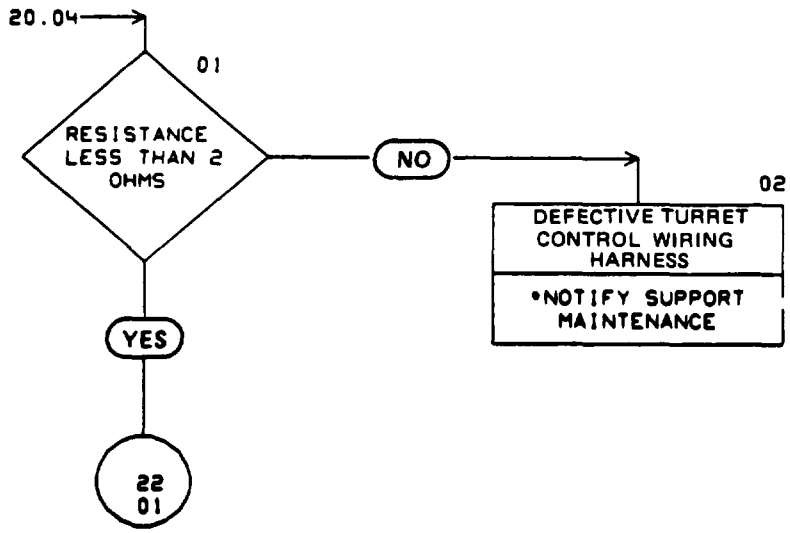

3-1. 7.62MM COAX MACHINE GUN TROUBLESHOOTING (SHEET 22 OF 28)

21.01 → 01

MEASURE VOLTAGE BETWEEN SOCKET A OF HARNESS CONNECTOR 100 ON TURRET POWER AND SEARCHLIGHT RELAY BOX AND GROUND

- REPLACE HARNESS CONNECTORS ON JACK (1) ON TURRET GUN FIRING RELAY BOX AND JACK (2) ON TURRET POWER AND SEARCHLIGHT RELAY BOX
- REMOVE HARNESS CONNECTOR 100 FROM JACK (3) ON TURRET POWER AND SEARCHLIGHT RELAY BOX
- SET 'MASTER BATTERY' SWITCH TO 'ON'
- USING MULTIMETER, MEASURE DC VOLTAGE

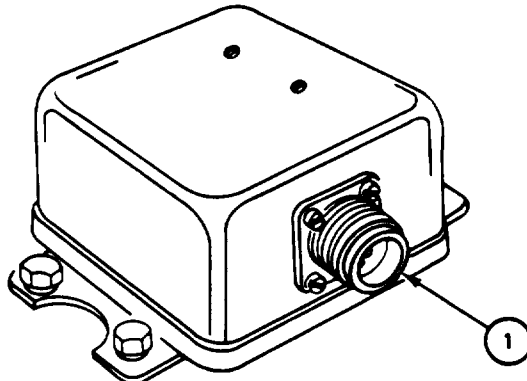

TURRET GUN FIRING RELAY BOX

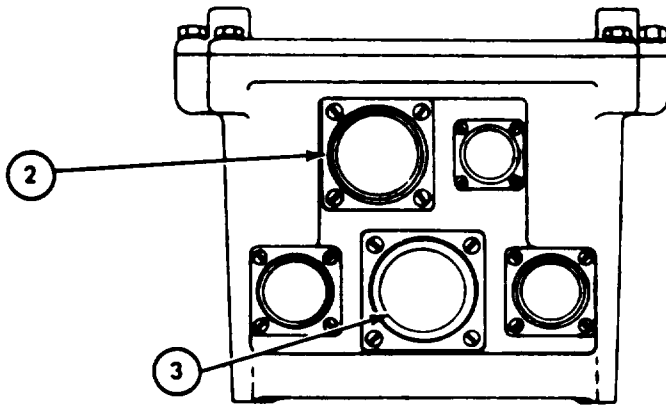

TURRET POWER AND SEARCHLIGHT RELAY BOX

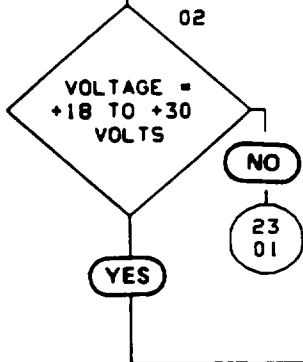

03

DEFECTIVE TURRET POWER AND SEARCHLIGHT RELAY BOX

- SET 'MASTER BATTERY' SWITCH TO 'OFF'
- REMOVE AND REPLACE TURRET POWER AND SEARCHLIGHT RELAY BOX (TM-20-2-3, PARA 9-2, 9-3)

3-1. 7.62MM COAX MACHINE GUN TROUBLESHOOTING (SHEET 23 OF 28)

22.02 →

01

CHECK CONTINUITY BETWEEN HARNESS CONNECTOR 100 ON TURRET ELECTRICAL SLIPRING AND HARNESS CONNECTOR 100 ON JACK (1) ON TURRET POWER AND SEARCHLIGHT RELAY BOX

•SET 'MASTER BATTERY' SWITCH TO 'OFF'

•REMOVE HARNESS CONNECTOR 100 FROM JACK (2) ON TURRET ELECTRICAL SLIPRING

•USING MULTIMETER, CHECK CONTINUITY

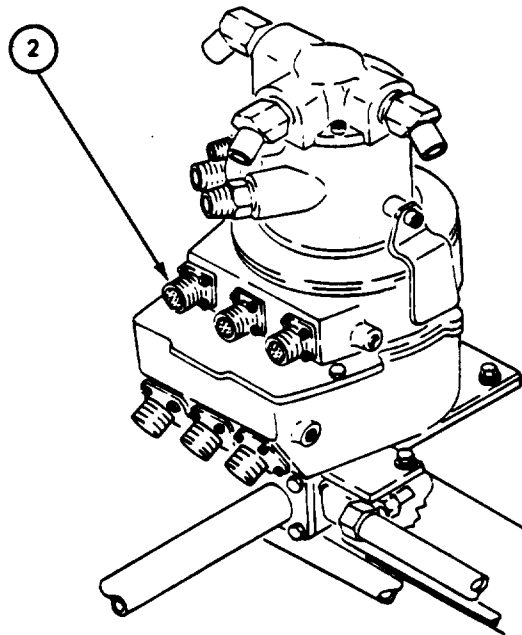

TURRET SLIPRING

02

RESISTANCE LESS THAN 2 OHMS

NO

04

DEFECTIVE SLIPRING TO TURRET POWER RELAY BOX WIRING HARNESS

•NOTIFY SUPPORT MAINTENANCE

YES

03

DEFECTIVE TURRET ELECTRICAL SLIPRING

•REPLACE HARNESS CONNECTOR 100 ON TURRET POWER AND SEARCHLIGHT RELAY BOX

REMOVE AND REPLACE TURRET ELECTRICAL SLIPRING (TM-20-2-3, PARA 3-7, 3-8)

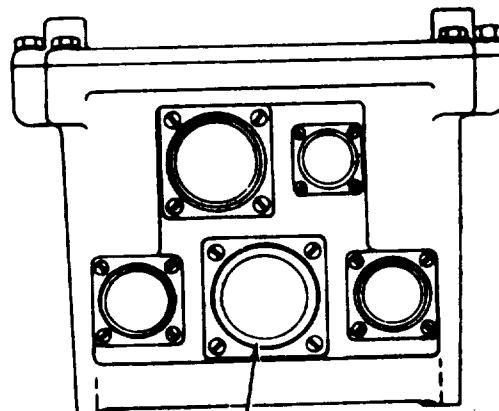

TURRET POWER AND SEARCHLIGHT RELAY BOX

3-1. 7.62MM COAX MACHINE GUN TROUBLESHOOTING (SHEET 24 OF 28)

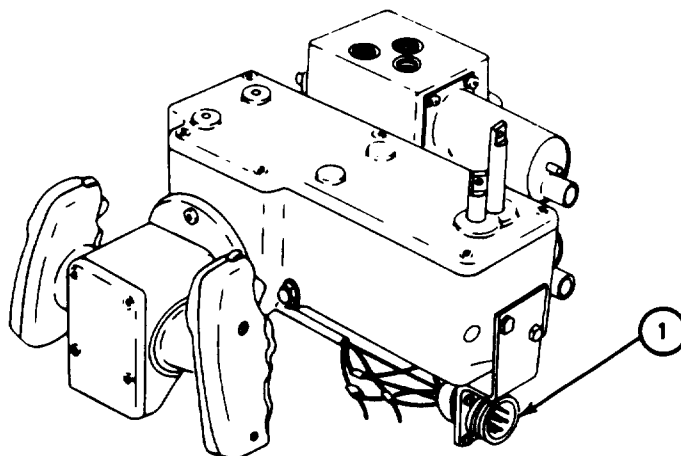
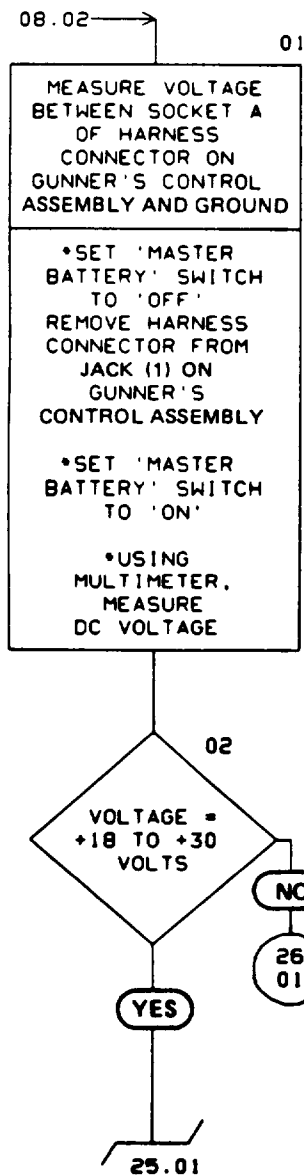

GUNNER'S CONTROL ASSEMBLY

3-1. 7.62MM COAX MACHINE GUN TROUBLESHOOTING (SHEET 25 OF 28)

24.02 →

01

CHECK CONTINUITY BETWEEN SOCKET B OF HARNESS CONNECTOR ON JACK (1) ON GUNNER'S CONTROL ASSEMBLY AND SOCKET G OF HARNESS CONNECTOR ON GUNNER'S CONTROL BOX

*SET 'MASTER BATTERY' SWITCH TO 'OFF'

*REMOVE HARNESS CONNECTOR (2) FROM JACK ON GUNNER'S CONTROL BOX

*USING MULTIMETER, CHECK CONTINUITY

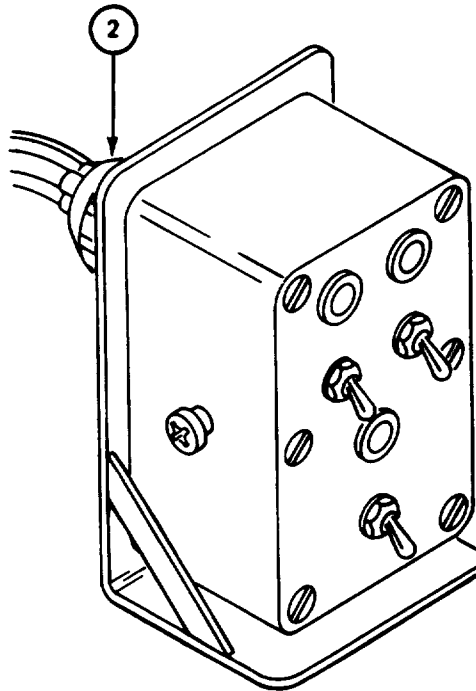

GUNNER'S CONTROL BOX

02

RESISTANCE LESS THAN 2 OHMS

NO

04

DEFECTIVE TURRET CONTROL WIRING HARNESS

*NOTIFY SUPPORT MAINTENANCE

YES

03

DEFECTIVE GUNNER'S CONTROL ASSEMBLY WIRING HARNESS

*SET 'MASTER BATTERY' SWITCH TO 'OFF'

*NOTIFY SUPPORT MAINTENANCE

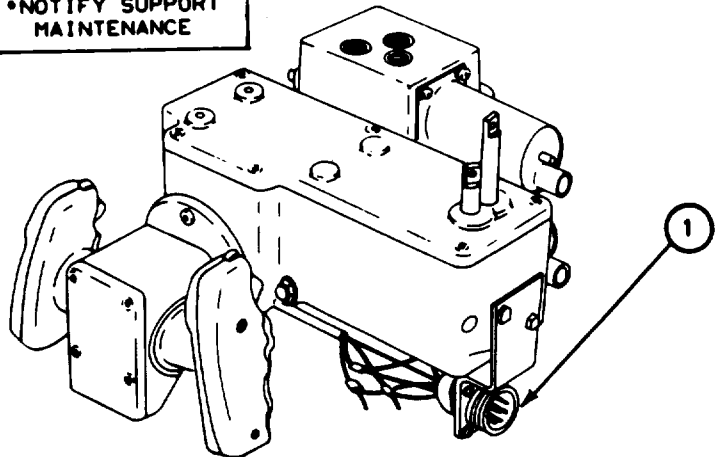

GUNNER'S CONTROL ASSEMBLY

3-1. 7.62MM COAX MACHINE GUN TROUBLESHOOTING (SHEET 26 OF 28)

24.02 →

01

CHECK CONTINUITY BETWEEN SOCKET A OF HARNESS CONNECTOR ON JACK (1) ON GUNNER'S CONTROL ASSEMBLY AND SOCKET B OF HARNESS CONNECTOR ON JACK ON COMMANDER'S CONTROL HANDLE
•SET 'MASTER BATTERY' SWITCH TO 'OFF'
•REMOVE HARNESS CONNECTOR FROM JACK (2) ON COMMANDER'S CONTROL HANDLE
•USING MULTIMETER, CHECK CONTINUITY

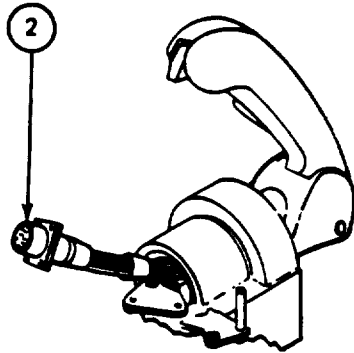

COMMANDER'S CONTROL HANDLE

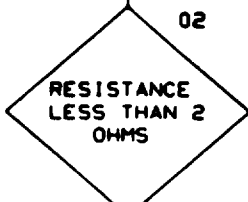

YES

NO

04

DEFECTIVE TURRET CONTROL WIRING HARNESS
•NOTIFY SUPPORT MAINTENANCE

03

DEFECTIVE COMMANDER'S CONTROL HANDLE
•SET 'MASTER BATTERY' SWITCH TO 'OFF'
•REMOVE AND REPLACE COMMANDER'S CONTROL HANDLE (TM-20-2-3, PARA 38-2, 38-3)

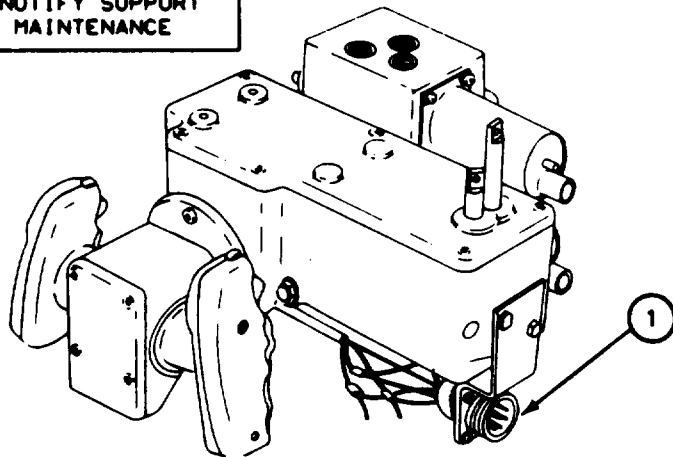

GUNNER'S CONTROL ASSEMBLY

3-1. 7.62MM COAX MACHINE GUN TROUBLESHOOTING (SHEET 27 OF 28)

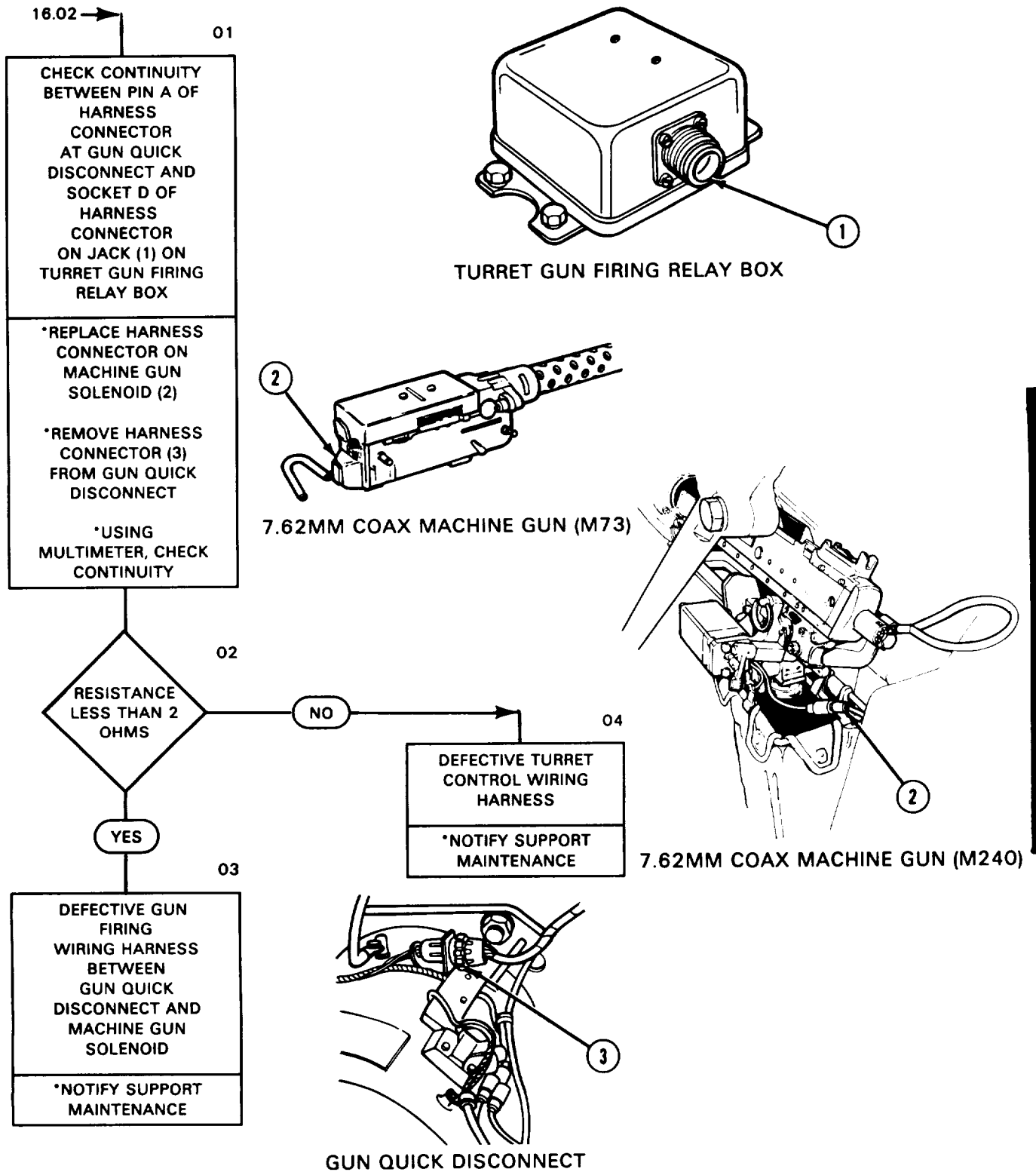

3-1. 7.62MM COAX MACHINE GUN TROUBLESHOOTING (SHEET 28 OF 28)

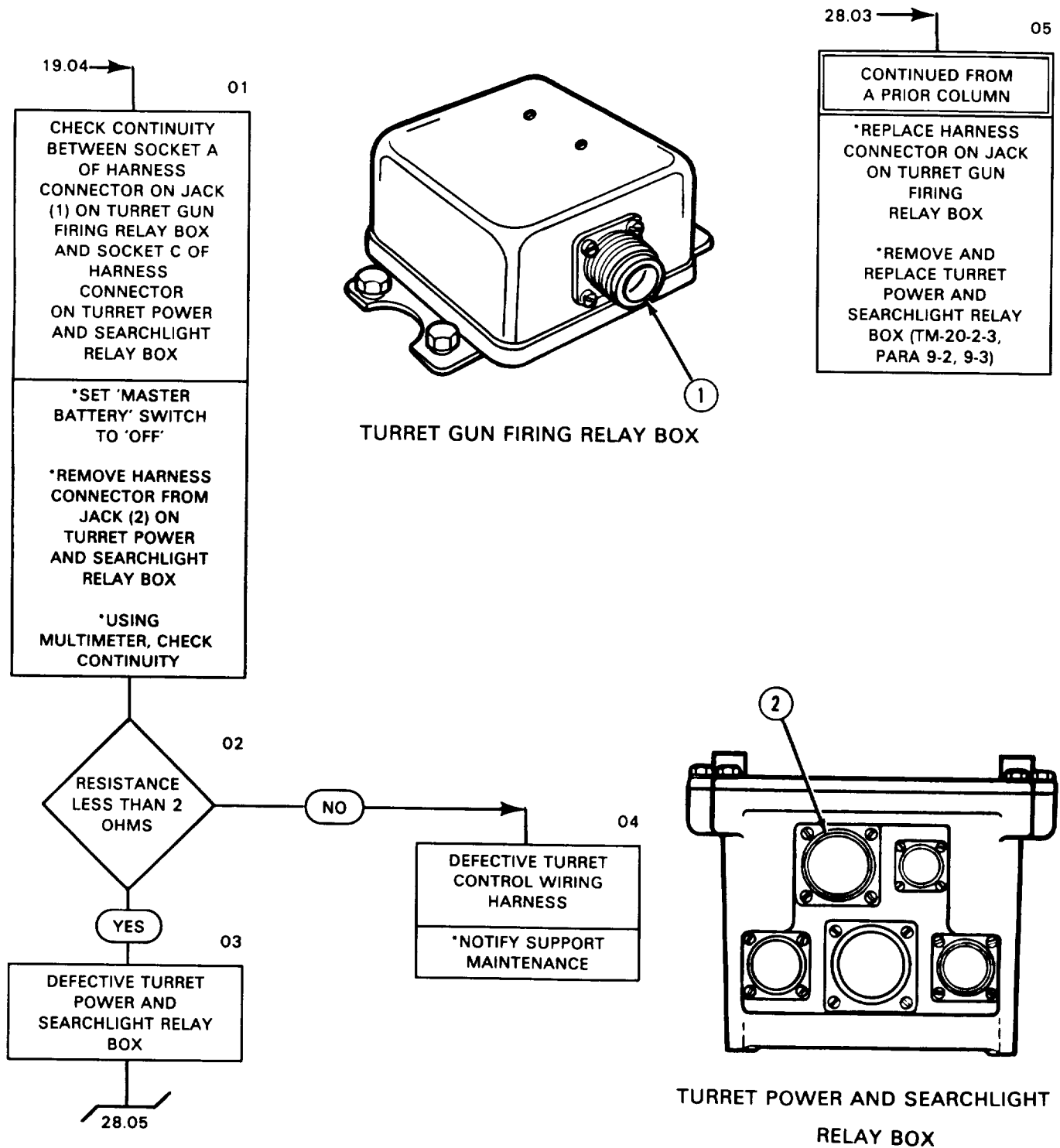

3-2. CALIBER .50 MACHINE GUN TROUBLESHOOTING (SHEET 1 OF 25)

SYMPTOM: (6) Caliber .50 machine gun fails to fire

TEST EQUIPMENT: Multimeter

PERSONNEL: Two

UNIT LOCATION:	FOLDOUT	CALLOUT
Master Control Panel	4	4
Cupola Safety Switch	2	14
Cupola Power Switch	2	1
Elevating Handle	2	18
Caliber .50 Machine Gun	2	16
Cupola Power Relay	2	1
Cupola Interconnecting Box	2	6
Turret Power and Searchlight Relay Box	1	9
Gunner's Dome Light	1	1
Turret Electrical Slipping	3	5

- REFERENCES:**
- (1) TM 9-2350-222-20-2-3 for removal and replacement of components
 - (2) ETM 643-091-9400R/JPG for procedures to:
Use multimeter
Disconnect electrical connectors
 - (3) TM 9-2350-222-10 for procedure to:
Remove ammunition

EQUIPMENT CONDITION: Vehicle parked, power off.
Caliber .50 machine gun mounted in cupola.

3-2. CAL .50 MACHINE GUN TROUBLESHOOTING (SHEET 2 OF 25)

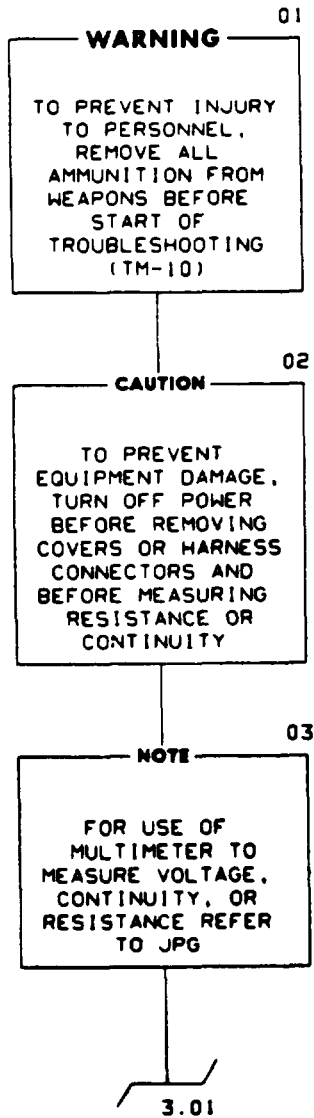

3-2. CAL .50 MACHINE GUN TROUBLESHOOTING (SHEET 3 OF 25)

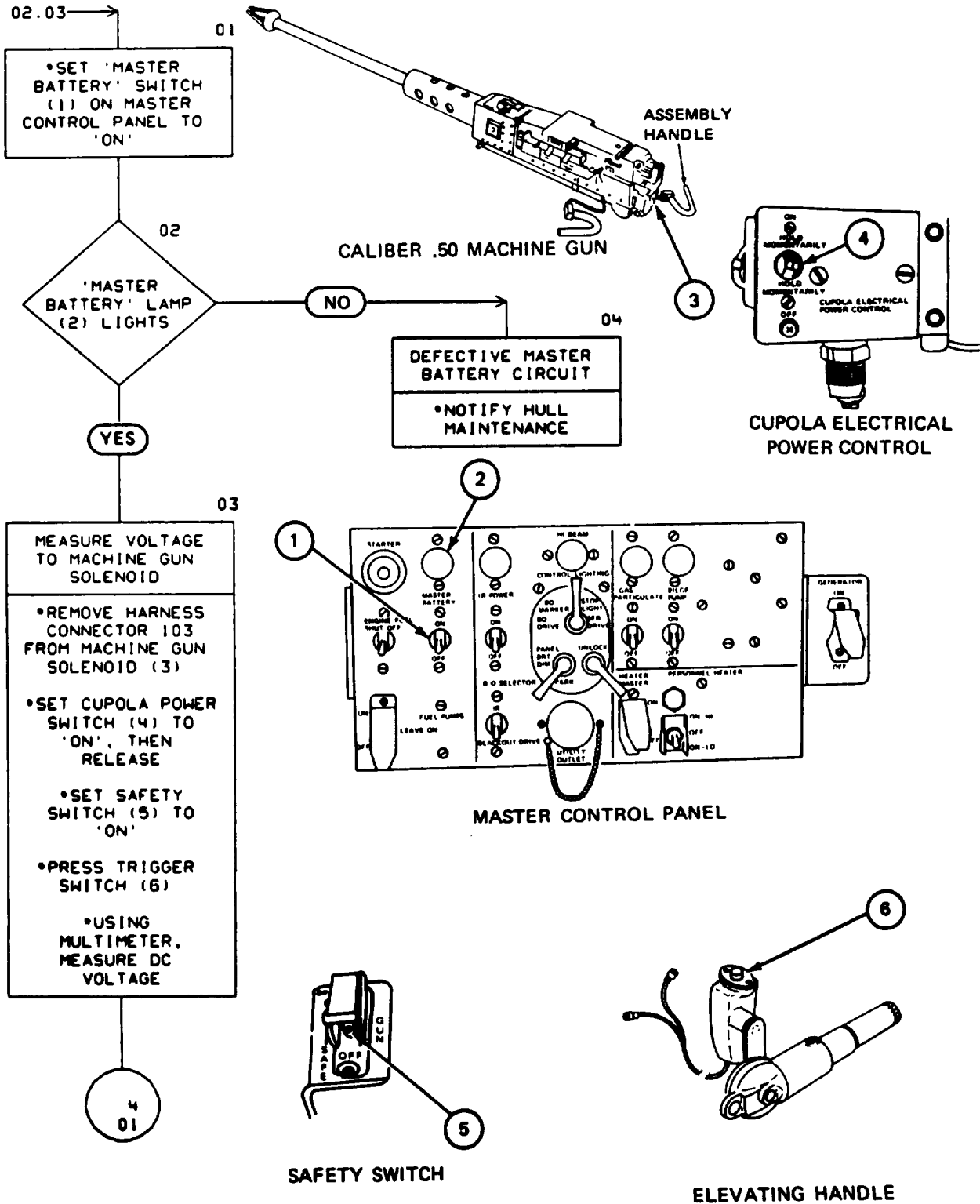

3-2. CAL .50 MACHINE GUN TROUBLESHOOTING (SHEET 4 OF 25)

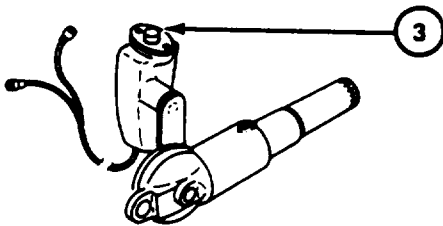
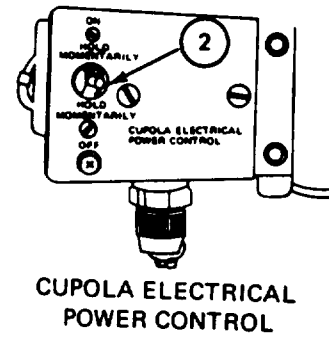
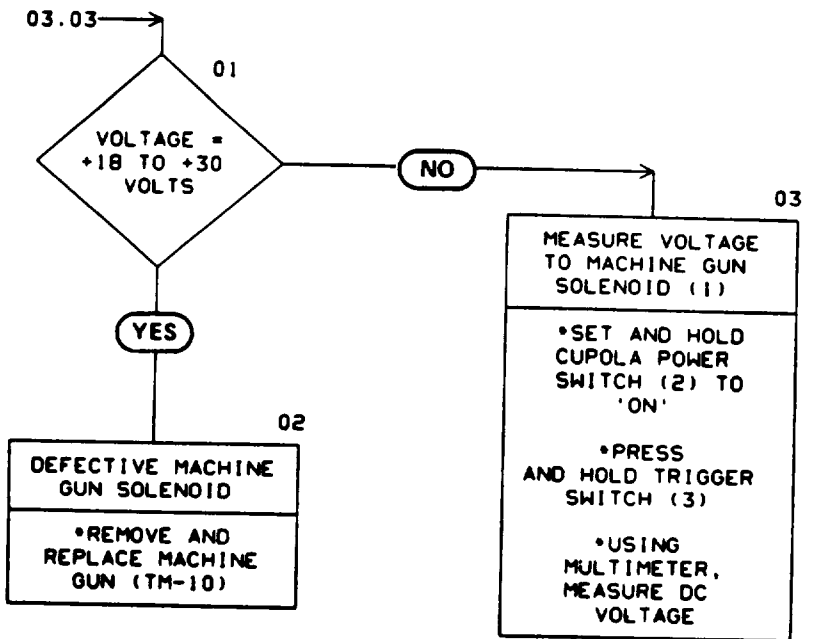

ELEVATING HANDLE

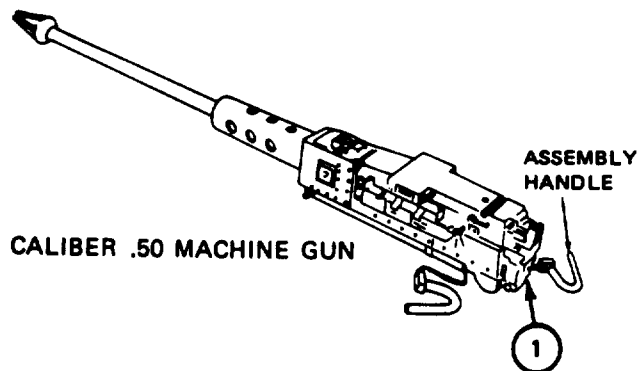
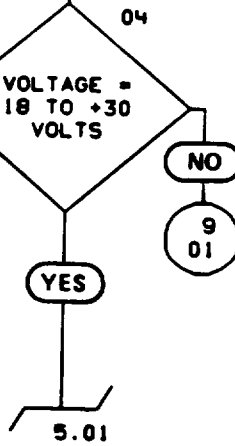

CALIBER .50 MACHINE GUN

3-2. CAL .50 MACHINE GUN TROUBLESHOOTING (SHEET 5 OF 25)

04.04 →

01

MEASURE VOLTAGE BETWEEN SOCKET A OF HARNESS CONNECTOR ON CUPOLA POWER RELAY AND GROUND

- *SET 'MASTER BATTERY' SWITCH TO 'OFF'
- *REMOVE HARNESS CONNECTOR (1) FROM JACK ON CUPOLA POWER RELAY
- *REPLACE HARNESS CONNECTOR 103 ON MACHINE GUN SOLENOID (2)
- *SET 'MASTER BATTERY' SWITCH TO 'ON'
- *SET AND HOLD CUPOLA POWER SWITCH (3) TO 'ON'
- *USING MULTIMETER, MEASURE DC VOLTAGE

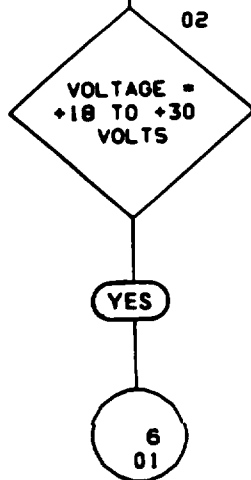
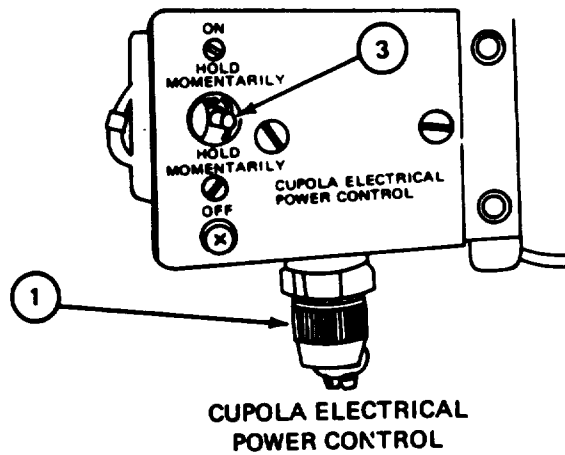
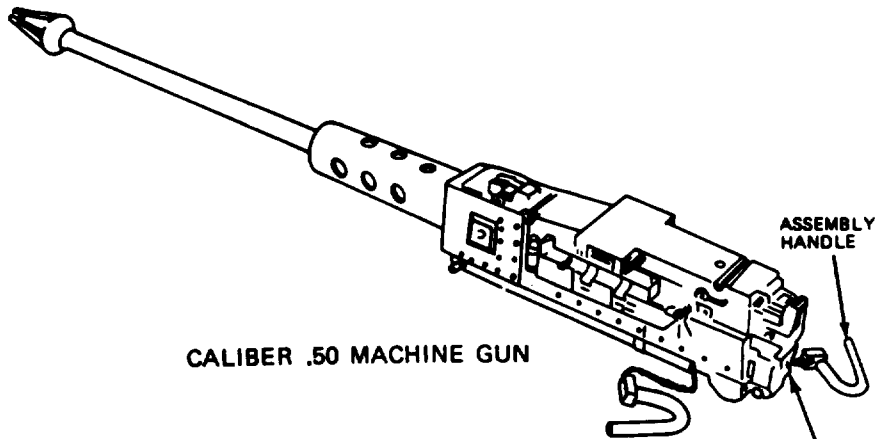

NO

03

DEFECTIVE BRANCHED WIRING HARNESS (10905888) BETWEEN SOCKET A OF HARNESS CONNECTOR ON CUPOLA POWER RELAY AND HARNESS CONNECTOR 111B ON CUPOLA POWER SWITCH

- *NOTIFY SUPPORT MAINTENANCE

3-2. CAL .50 MACHINE GUN TROUBLESHOOTING (SHEET 6 OF 25)

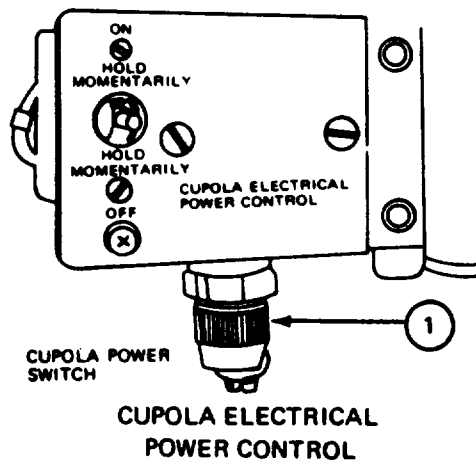
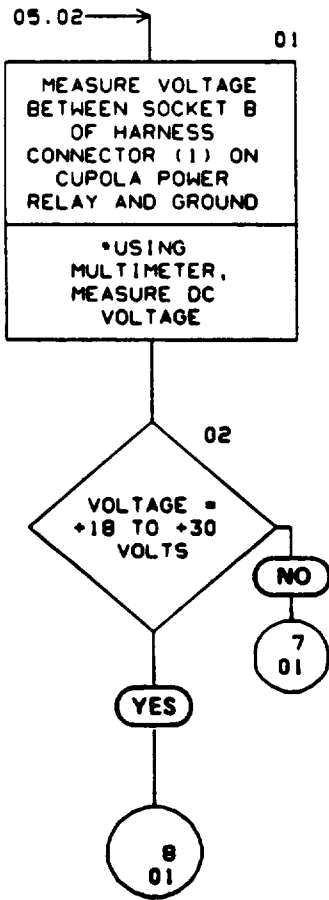

3-2. CAL .50 MACHINE GUN TROUBLESHOOTING (SHEET 7 OF 25)

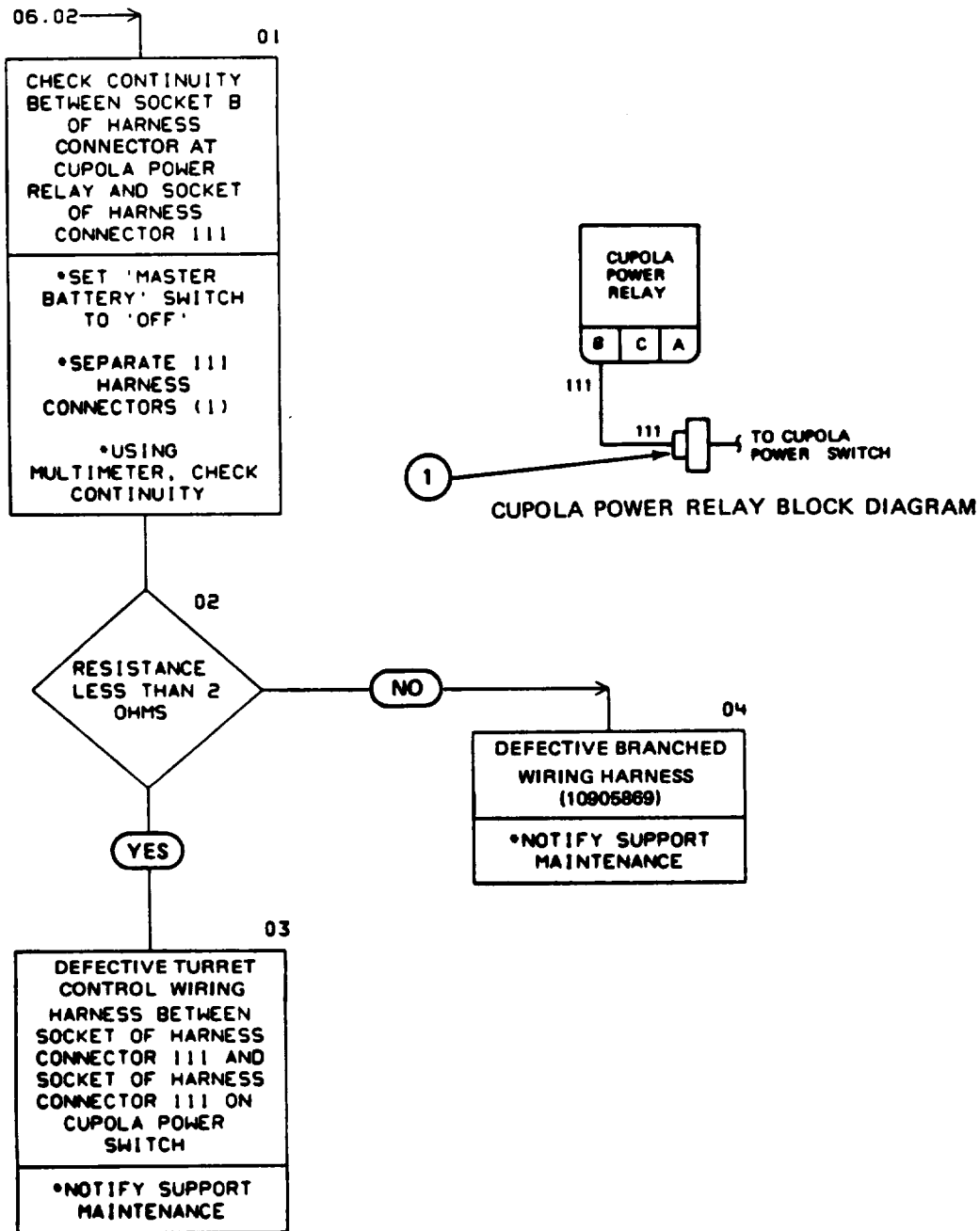

3-2. CAL .50 MACHINE GUN TROUBLESHOOTING (SHEET 8 OF 25)

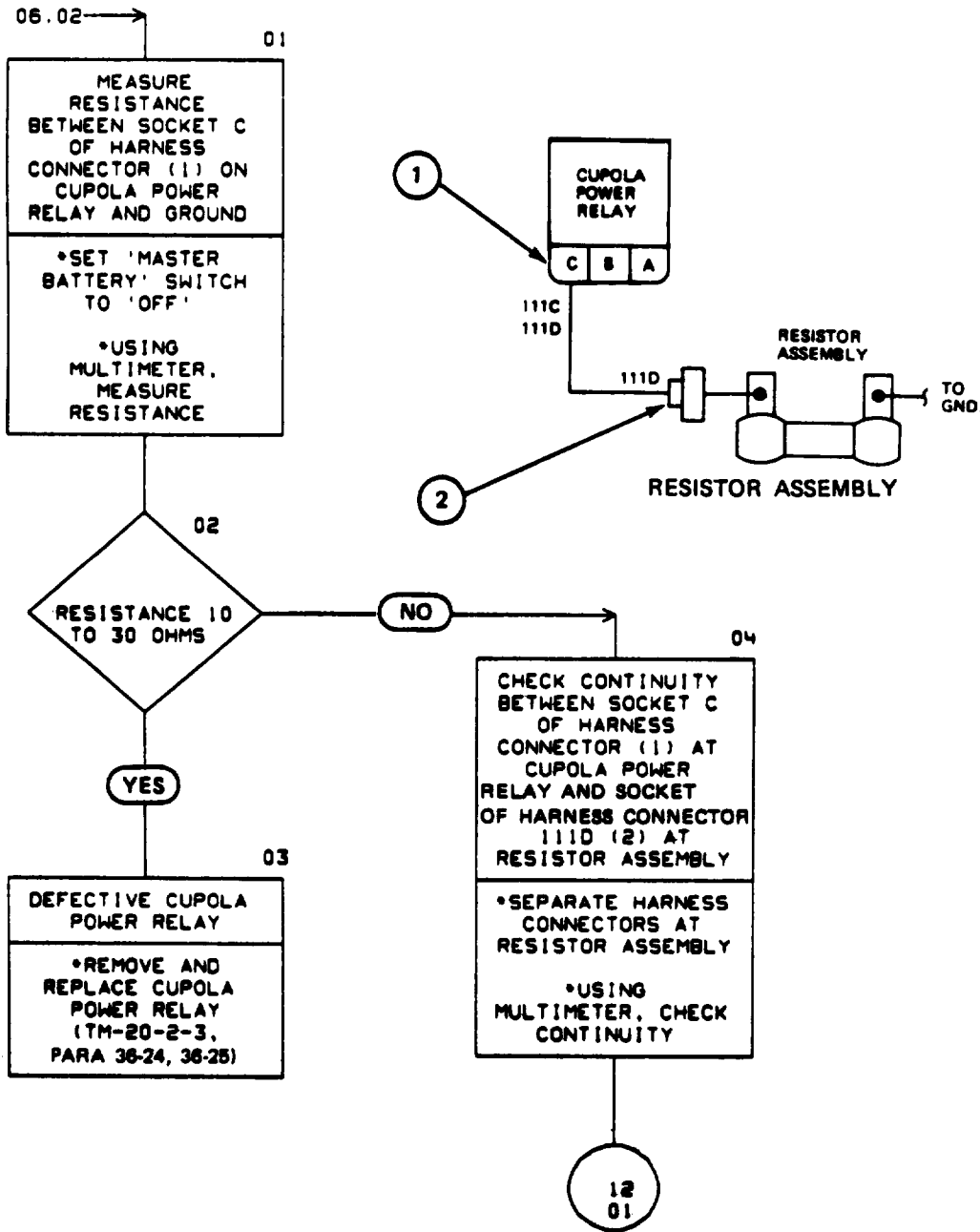

3-2. CAL .50 MACHINE GUN TROUBLESHOOTING (SHEET 9 OF 25)

04.04 →

01

MEASURE VOLTAGE BETWEEN SOCKET OF HARNESS CONNECTOR III ON CUPOLA POWER SWITCH AND GROUND

- SET 'MASTER BATTERY' SWITCH TO 'OFF'
- REPLACE HARNESS CONNECTOR ON MACHINE GUN SOLENOID (1)
- SET SAFETY SWITCH (2) TO 'OFF'
- REMOVE HARNESS CONNECTOR III (3) FROM CUPOLA POWER SWITCH
- SET 'MASTER BATTERY' SWITCH TO 'ON'
- USING MULTIMETER, MEASURE DC VOLTAGE

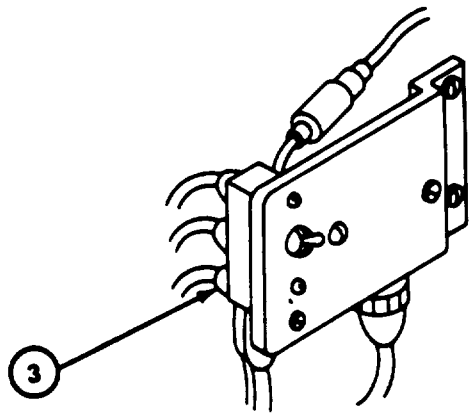
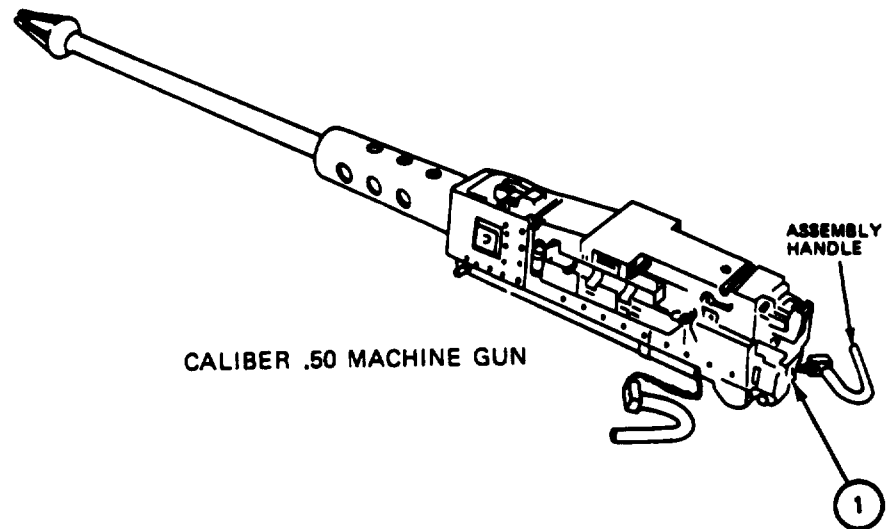

CUPOLA ELECTRICAL POWER CONTROL CONNECTORS

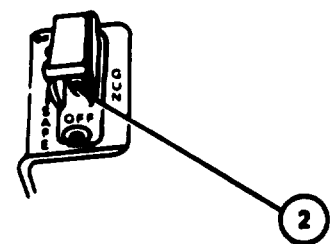
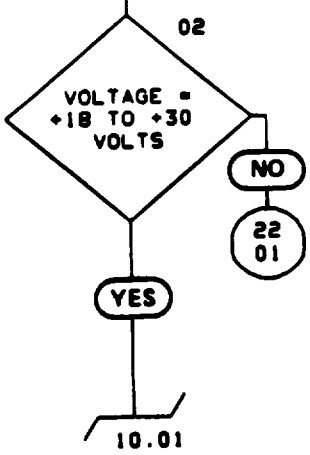

SAFETY SWITCH

3-2. CAL .50 MACHINE GUN TROUBLESHOOTING (SHEET 10 OF 25)

09.02 → 01

MEASURE VOLTAGE BETWEEN SOCKET B OF HARNESS CONNECTOR ON CUPOLA INTER-CONNECTING BOX AND GROUND

•SET 'MASTER BATTERY' SWITCH TO 'OFF'

•REPLACE HARNESS CONNECTOR 111 (1) ON CUPOLA POWER SWITCH

•REMOVE HARNESS CONNECTOR (2) FROM JACK ON CUPOLA INTERCONNECTING BOX

•SET 'MASTER BATTERY' SWITCH TO 'ON'

•SET CUPOLA POWER SWITCH (3) TO 'ON' THEN RELEASE

•USING MULTIMETER, MEASURE DC VOLTAGE

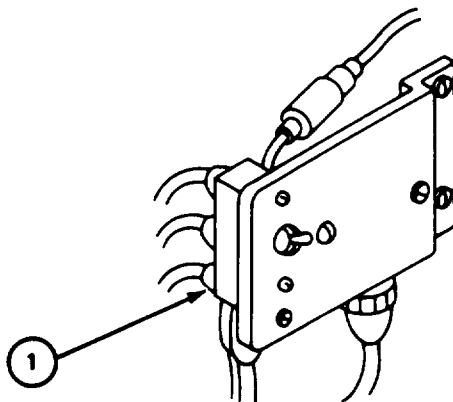
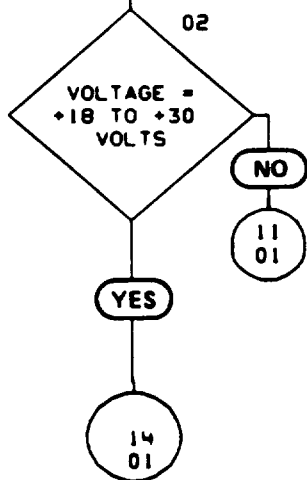

CUPOLA ELECTRICAL POWER CONTROL CONNECTORS

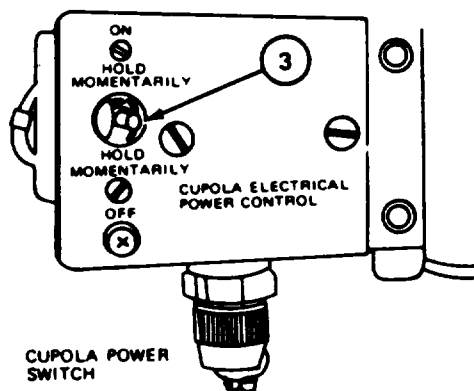

CUPOLA POWER SWITCH
CUPOLA ELECTRICAL POWER CONTROL

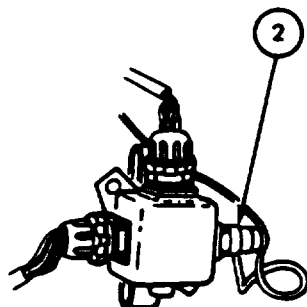

CUPOLA INTERCONNECTING BOX

3-2. CAL .50 MACHINE GUN TROUBLESHOOTING (SHEET 11 OF 25)

10.02 →

01

CHECK CONTINUITY BETWEEN SOCKET B OF HARNESS CONNECTOR (1) ON CUPOLA INTERCONNECTING BOX AND SOCKET OF HARNESS CONNECTOR 111B ON CUPOLA POWER SWITCH

• SET 'MASTER BATTERY' SWITCH TO 'OFF'

• REMOVE HARNESS CONNECTOR 111B (2) FROM CUPOLA POWER SWITCH

• USING MUTIMETER CHECK CONTINUITY

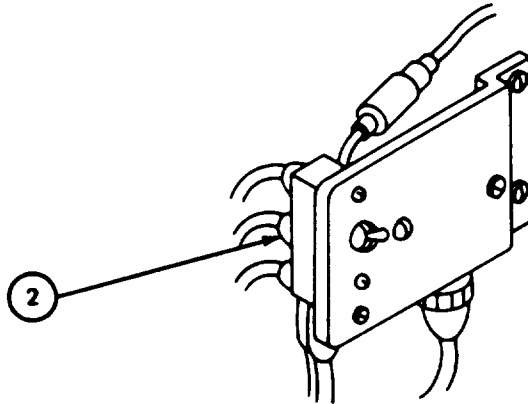

CUPOLA ELECTRICAL POWER CONTROL CONNECTORS



YES

NO

03

DEFECTIVE CUPOLA POWER SWITCH

• REMOVE AND REPLACE CUPOLA POWER SWITCH (TM-20-2-3, PARA 36-21, 36-22)

04

DEFECTIVE BRANCHED WIRING HARNESS (10905889)

• NOTIFY SUPPORT MAINTENANCE

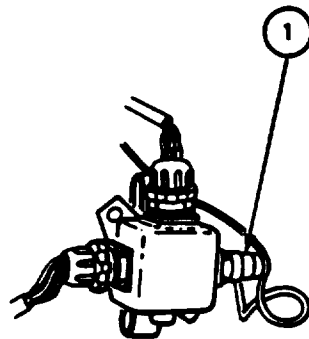

CUPOLA INTERCONNECTING BOX

3-2. CAL .50 MACHINE GUN TROUBLESHOOTING (SHEET 12 OF 25)

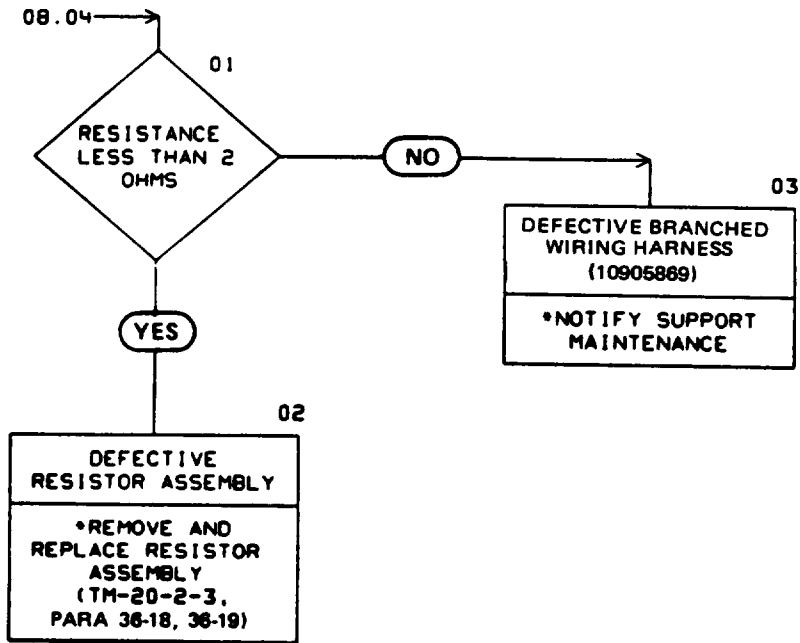

3-2. CAL .50 MACHINE GUN TROUBLESHOOTING (SHEET 13 OF 25)

22.02 → 01

CHECK CONTINUITY BETWEEN HARNESS CONNECTOR 111 (1) AT CUPOLA POWER SWITCH AND SOCKET A, CIRCUIT 111, OF HARNESS CONNECTOR ON TURRET POWER AND SEARCHLIGHT RELAY BOX

*SET 'MASTER BATTERY' SWITCH TO 'OFF'

*REMOVE HARNESS CONNECTOR FROM JACK (2) ON TURRET POWER AND SEARCHLIGHT RELAY BOX

*USING MULTIMETER, CHECK CONTINUITY

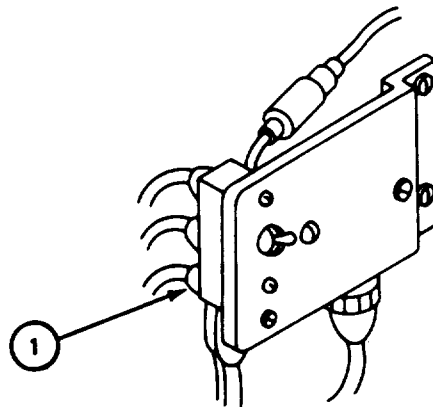

CUPOLA ELECTRICAL POWER CONTROL CONNECTORS

13.02 → 04

DEFECTIVE TURRET POWER AND SEARCHLIGHT RELAY BOX

*REPLACE HARNESS CONNECTOR 111 ON JACK ON CUPOLA POWER SWITCH

*REMOVE AND REPLACE TURRET POWER AND SEARCHLIGHT RELAY BOX (TM-20-2-3, PARA 9-2, 9-3)

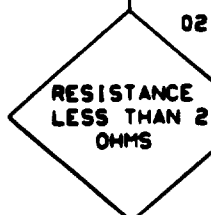

YES

13
04

NO

03

DEFECTIVE TURRET CONTROL WIRING HARNESS

*NOTIFY SUPPORT MAINTENANCE

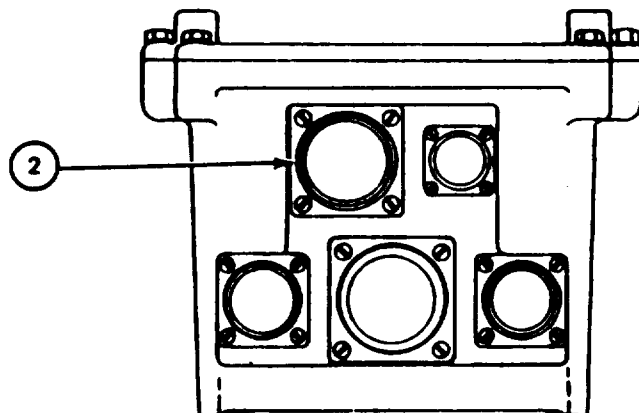

TURRET POWER AND SEARCHLIGHT RELAY BOX

3-2. CAL .50 MACHINE GUN TROUBLESHOOTING (SHEET 14 OF 25)

10.02* →

01

MEASURE VOLTAGE BETWEEN SOCKET OF HARNESS CONNECTOR 111 ON SAFETY SWITCH AND GROUND

NOTE
 POSITIVE SOCKET WILL HAVE WIRE COMING FROM CUPOLA RING. YOU WILL HAVE TO TRACE THE WIRE TO DETERMINE WHICH ONE IS POSITIVE

- SET 'MASTER BATTERY' SWITCH TO 'OFF'
- REPLACE HARNESS CONNECTOR (1) ON JACK ON CUPOLA INTERCONNECTING BOX
- REMOVE HARNESS CONNECTOR 111 FROM SAFETY SWITCH (2)
- SET 'MASTER BATTERY' SWITCH TO 'ON'
- SET CUPOLA POWER SWITCH (3) TO 'ON', THEN RELEASE
- USING MULTIMETER, MEASURE DC VOLTAGE

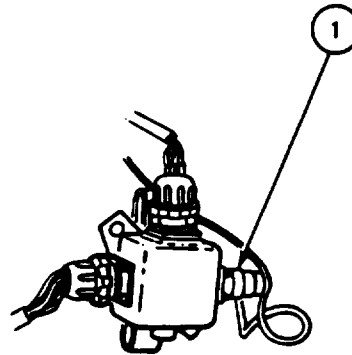

CUPOLA INTERCONNECTING BOX

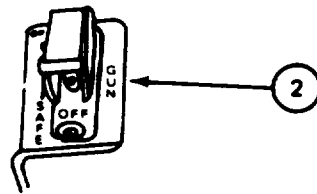

SAFETY SWITCH

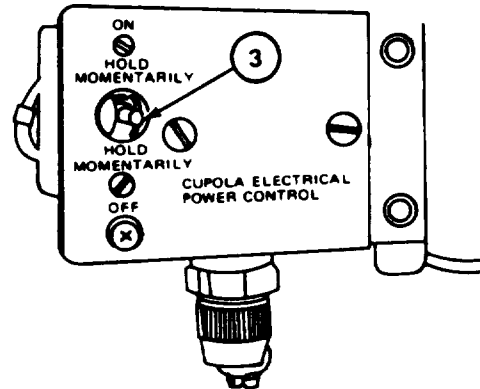

CUPOLA ELECTRICAL POWER CONTROL

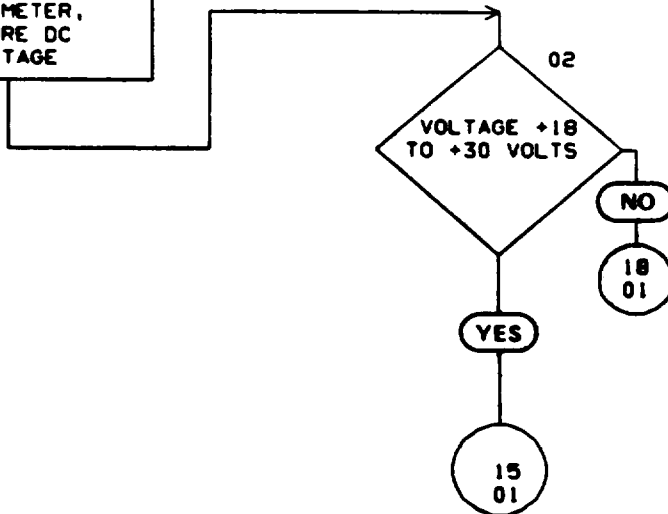

3-2. CAL .50 MACHINE GUN TROUBLESHOOTING (SHEET 15 OF 25)

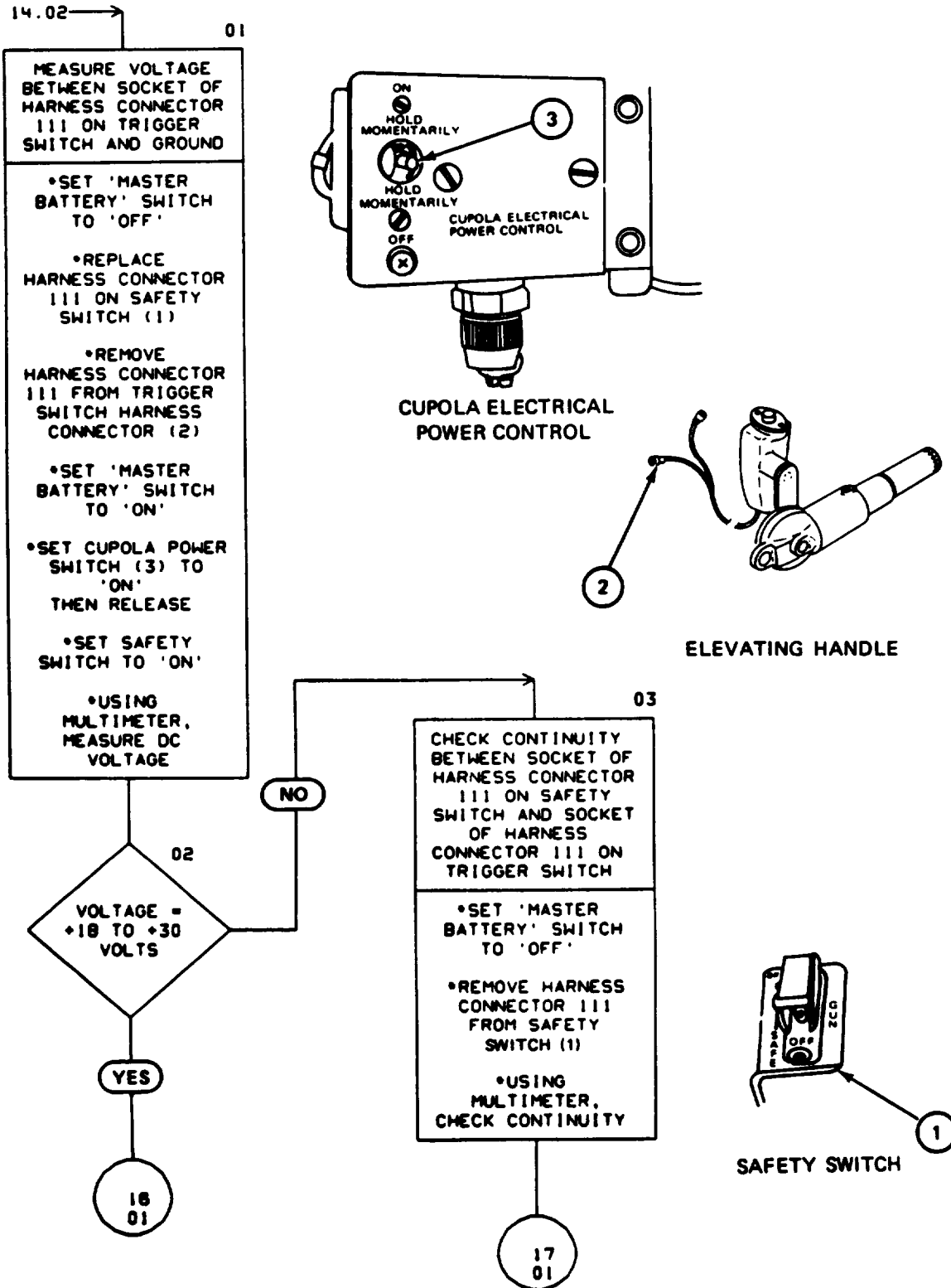

3-2. CAL .50 MACHINE GUN TROUBLESHOOTING (SHEET 16 OF 25)

15.02 → 01

CHECK CONTINUITY BETWEEN SOCKET OF HARNESS CONNECTOR 103 ON TRIGGER SWITCH AND SOCKET OF HARNESS CONNECTOR 103 ON MACHINE GUN SOLENOID

- SET 'MASTER BATTERY' SWITCH TO 'OFF'
- REPLACE HARNESS CONNECTOR 111 ON TRIGGER SWITCH HARNESS CONNECTOR (1)
- REMOVE HARNESS CONNECTORS 103 FROM TRIGGER SWITCH HARNESS CONNECTOR (2) AND MACHINE GUN SOLENOID (3)
- USING MULTIMETER, CHECK CONTINUITY

16.03 → NOTE 05

CONTINUED FROM A PRIOR COLUMN

- REMOVE AND REPLACE TRIGGER SWITCH (TM-20-2-3, PARA 36-73, 36-74)

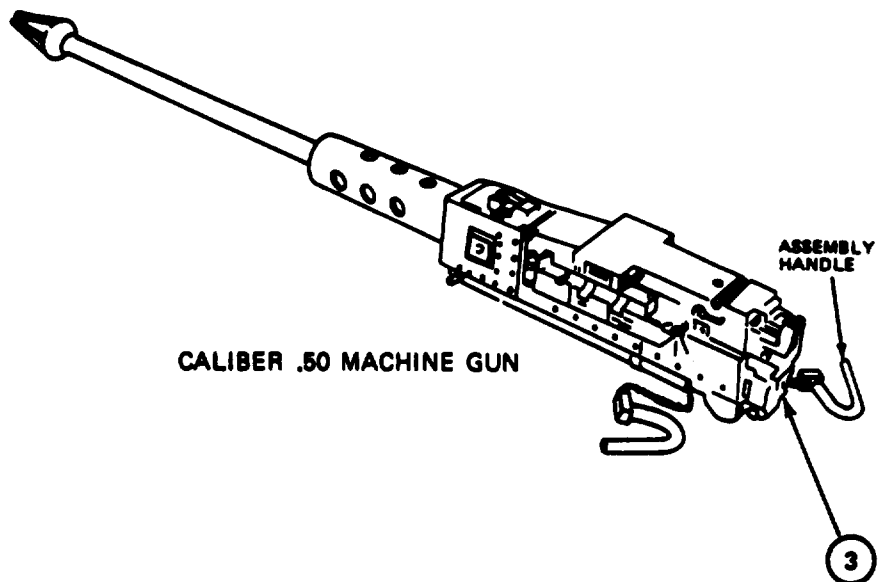

02

RESISTANCE LESS THAN 2 OHMS

YES

NO

04

DEFECTIVE ELECTRICAL LEAD (10024501)

- NOTIFY SUPPORT MAINTENANCE

03

DEFECTIVE TRIGGER SWITCH

16.05

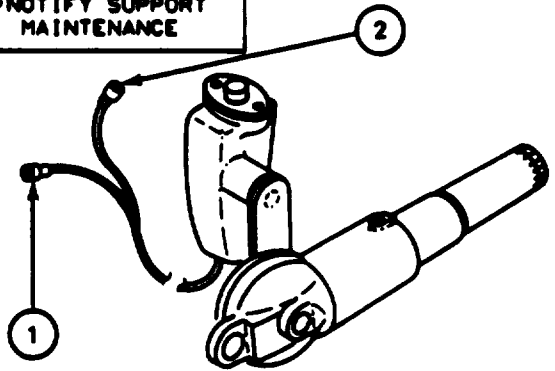

3-2. CAL .50 MACHINE GUN TROUBLESHOOTING (SHEET 17 OF 25)

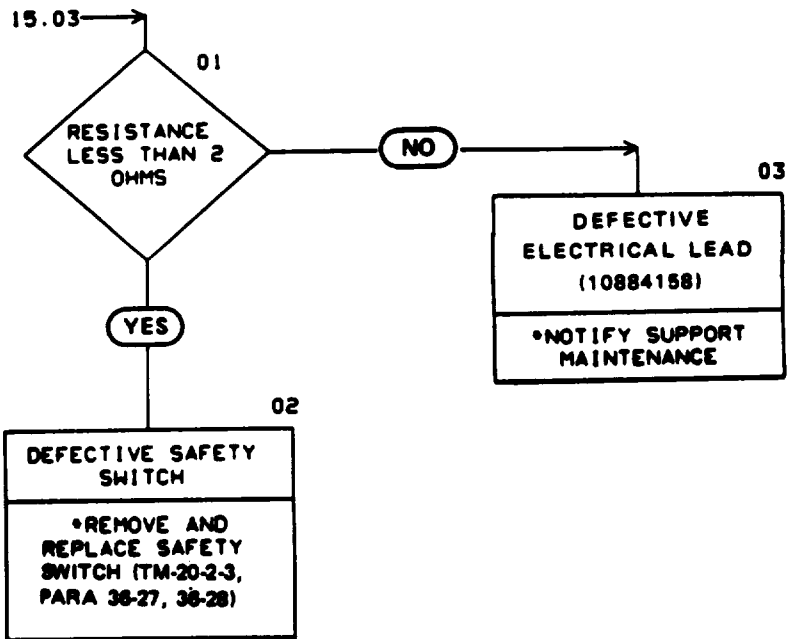

3-2. CAL .50 MACHINE GUN TROUBLESHOOTING (SHEET 18 OF 25)

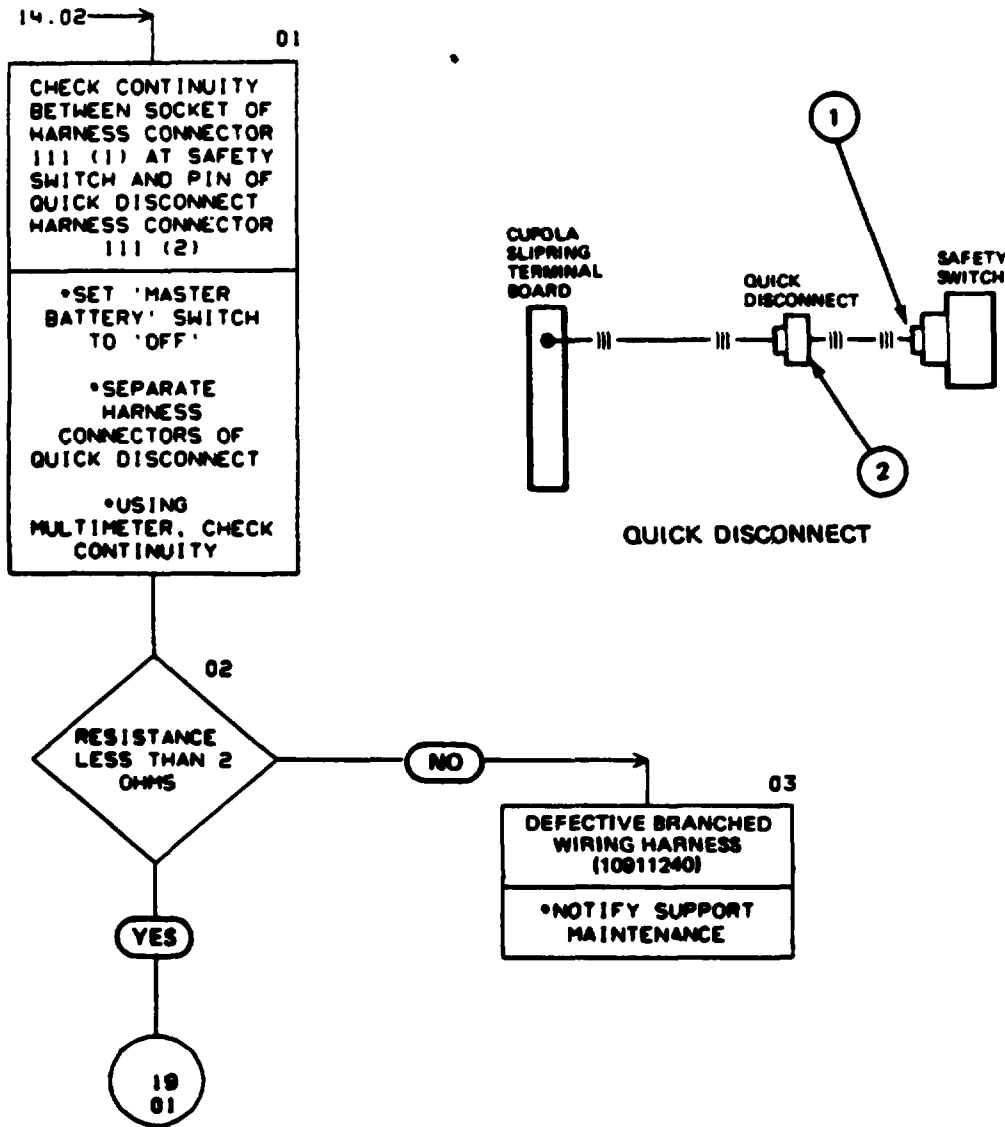

3-2. CAL .50 MACHINE GUN TROUBLESHOOTING (SHEET 19 OF 25)

18.02 →

01

CHECK CONTINUITY BETWEEN SOCKET OF HARNESS CONNECTOR III (1) AT QUICK DISCONNECT AND PIN B OF HARNESS CONNECTORS ON CUPOLA INTERCONNECTING BOX

• REMOVE HARNESS CONNECTORS (2) AND (3) FROM JACKS ON CUPOLA INTERCONNECTING BOX

• USING MULTIMETER, CHECK CONTINUITY WHILE ROTATING CUPOLA (TM-10) UNTIL READING IS RECEIVED OR UNTIL CUPOLA HAS ROTATED FULL CIRCLE

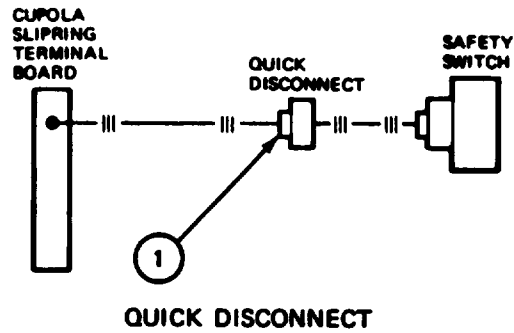

02

RESISTANCE LESS THAN 2 OHMS FROM BOTH CONNECTORS

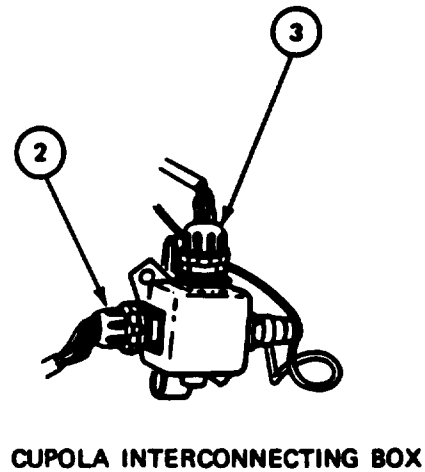
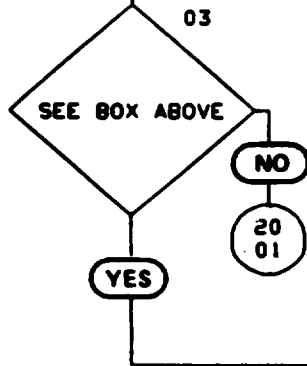

04

DEFECTIVE CUPOLA INTERCONNECTING BOX

• REMOVE AND REPLACE CUPOLA INTERCONNECTING BOX (TM-20-2-3, PARA 38-15, 38-18)

3-2. CAL .50 MACHINE GUN TROUBLESHOOTING (SHEET 20 OF 25)

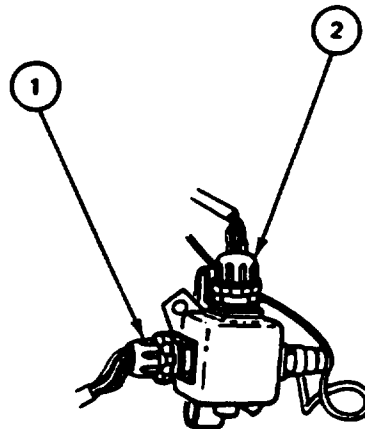
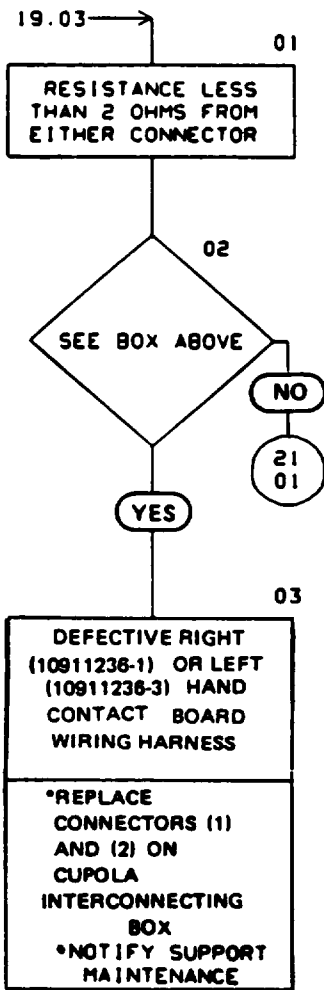

CUPOLA INTERCONNECTING BOX

3-2. CAL .50 MACHINE GUN TROUBLESHOOTING (SHEET 21 OF 25)

20.02 →

01

CHECK CONTINUITY BETWEEN SOCKET OF QUICK DISCONNECT HARNESS CONNECTOR (1) AND CONTACT 2 (2) OF TERMINAL BOARD ON CUPOLA SLIPRING

• REPLACE HARNESS CONNECTOR 111 (3) ON SAFETY SWITCH

• ROTATE CUPOLA (TM-10) UNTIL SLOT (4) BY AZIMUTH LOCK IS ALIGNED WITH TERMINAL BOARD

• USING MULTIMETER, CHECK CONTINUITY

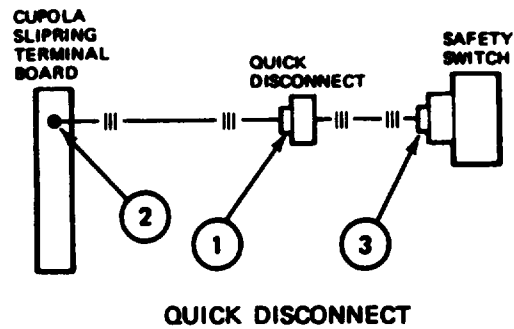

02

RESISTANCE LESS THAN 2 OHMS

YES

03

DEFECTIVE CUPOLA TERMINAL BOARD AND PAD ASSEMBLY

• NOTIFY SUPPORT MAINTENANCE

NO

04

DEFECTIVE WIRING HARNESS (10873581)

• NOTIFY SUPPORT MAINTENANCE

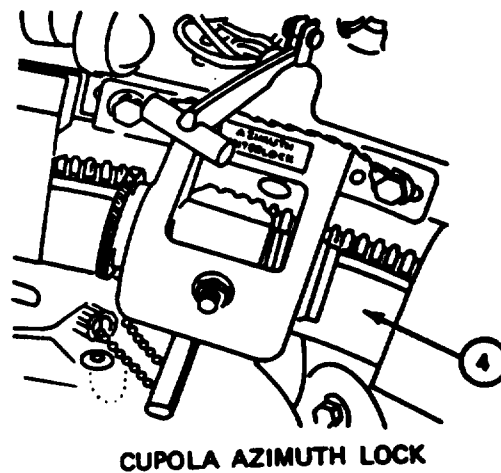

3-2. CAL .50 MACHINE GUN TROUBLESHOOTING (SHEET 22 OF 25)

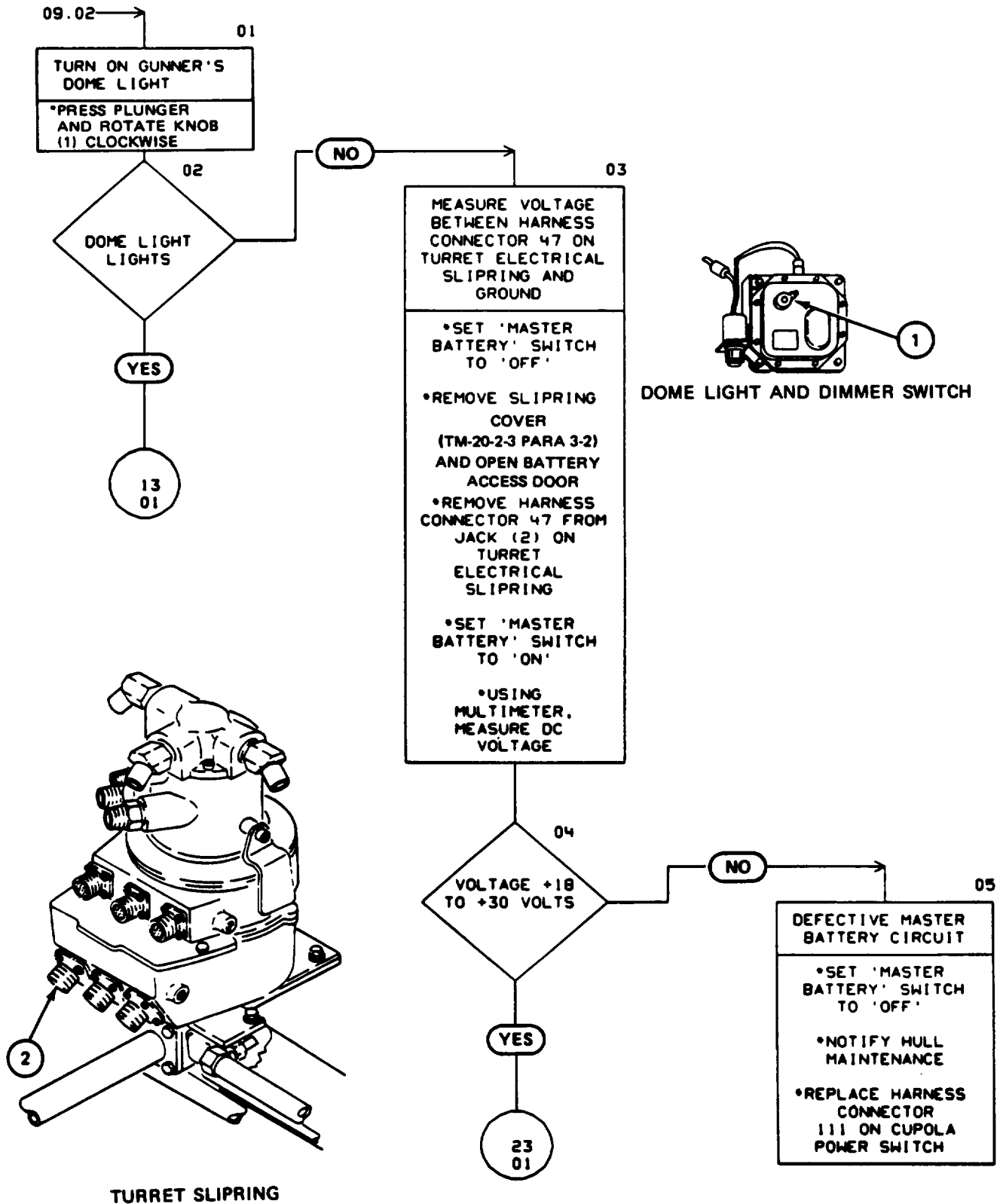

3-2. CAL .50 MACHINE GUN TROUBLESHOOTING (SHEET 23 OF 25)

22.04 →

01

MEASURE VOLTAGE BETWEEN SOCKET A OF HARNESS CONNECTOR 100 ON TURRET POWER AND SEARCHLIGHT RELAY BOX AND GROUND

- SET 'MASTER BATTERY' SWITCH TO 'OFF'
- REPLACE HARNESS CONNECTOR 47 ON JACK (1) ON TURRET ELECTRICAL SLIPRING
- REMOVE GUNNER'S FOOT PLATFORM
- REMOVE HARNESS CONNECTOR, CIRCUIT 100, FROM JACK (2) ON TURRET POWER AND SEARCHLIGHT RELAY BOX
- SET 'MASTER BATTERY' SWITCH TO 'ON'
- USING MULTIMETER, MEASURE DC VOLTAGE

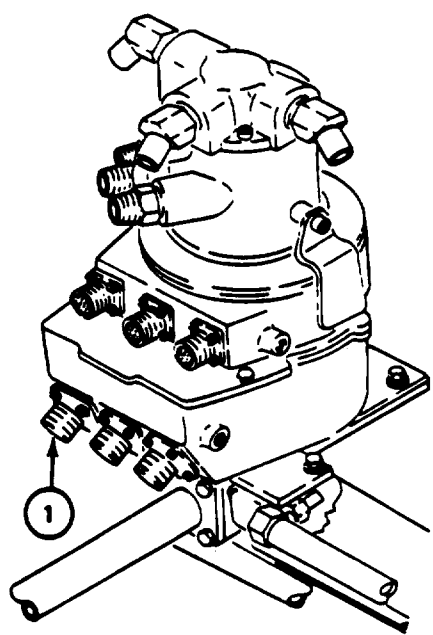

TURRET SLIPRING

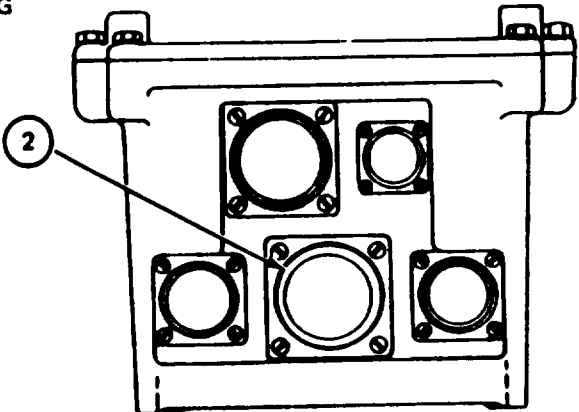

TURRET POWER AND SEARCHLIGHT RELAY BOX

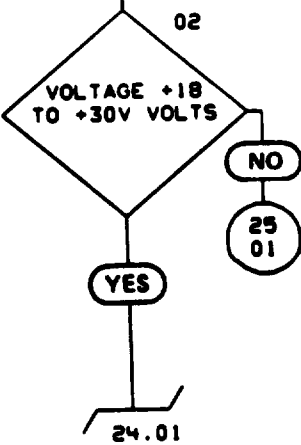

3-2. CAL .50 MACHINE GUN TROUBLESHOOTING (SHEET 24 OF 25)

23.02 → 01

CHECK CONTINUITY BETWEEN HARNESS CONNECTOR 111 (1) AT CUPOLA POWER SWITCH AND SOCKET A, CIRCUIT 111, OF HARNESS CONNECTOR ON TURRET POWER AND SEARCHLIGHT RELAY BOX

•SET 'MASTER BATTERY' SWITCH TO 'OFF'

•REPLACE HARNESS CONNECTOR 100 ON JACK (2) ON TURRET POWER AND SEARCHLIGHT RELAY BOX

•REMOVE HARNESS CONNECTOR, CIRCUIT 111 FROM JACK (3) ON TURRET POWER AND SEARCHLIGHT RELAY BOX

•USING MULTIMETER, CHECK CONTINUITY

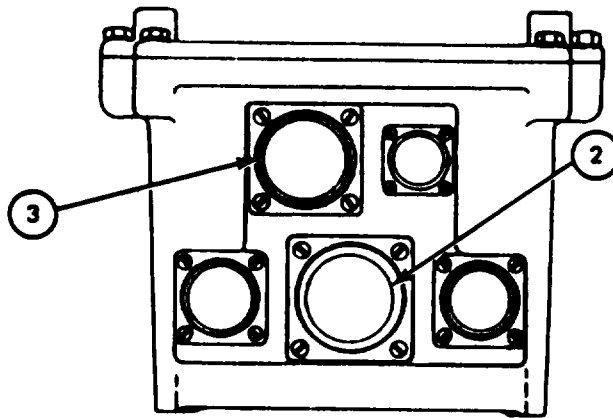

TURRET POWER AND SEARCHLIGHT RELAY BOX

02
RESISTANCE LESS THAN 2 OHMS

YES

NO

03
DEFECTIVE TURRET TURRET CONTROL WIRING HARNESS
•NOTIFY SUPPORT MAINTENANCE

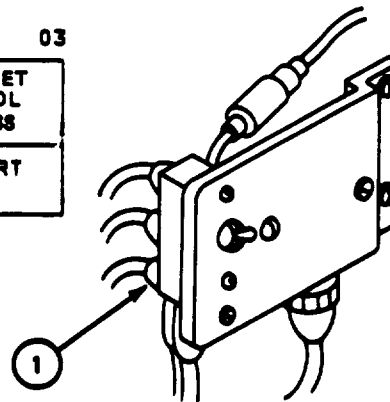

CUPOLA ELECTRICAL POWER CONTROL CONNECTORS

04
DEFECTIVE TURRET POWER AND SEARCHLIGHT RELAY BOX
•REPLACE HARNESS CONNECTOR 111 (1) ON CUPOLA POWER SWITCH
•REMOVE AND REPLACE TURRET POWER AND SEARCHLIGHT RELAY BOX (TM-20-2-3, PARA 9-2, 9-3)

3-2. CAL .50 MACHINE GUN TROUBLESHOOTING (SHEET 25 OF 25)

23.02 →

01

CHECK CONTINUITY BETWEEN HARNESS CONNECTOR 100 ON TURRET ELECTRICAL SLIPRING AND SOCKET A OF HARNESS CONNECTOR 100 ON JACK (1) ON TURRET POWER AND SEARCHLIGHT RELAY BOX

•SET 'MASTER BATTERY' SWITCH TO 'OFF'

•REMOVE HARNESS CONNECTOR 100 FROM JACK (2) ON TURRET ELECTRICAL SLIPRING

•USING MULTIMETER, CHECK CONTINUITY

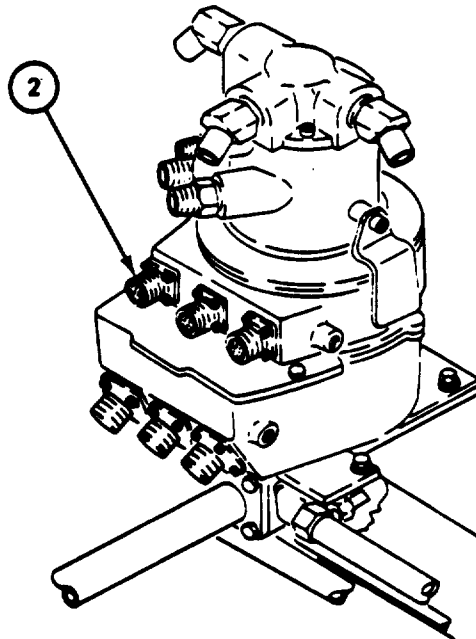

TURRET SLIPRING

02

RESISTANCE LESS THAN 2 OHMS

NO

04

DEFECTIVE SLIPRING TO TURRET POWER RELAY BOX WIRING HARNESS

•NOTIFY SUPPORT MAINTENANCE

YES

03

DEFECTIVE TURRET ELECTRICAL SLIPRING

•CONNECT HARNESS CONNECTOR 100 TO JACK (1) ON TURRET POWER AND SEARCHLIGHT RELAY BOX

•REMOVE AND REPLACE TURRET ELECTRICAL SLIPRING (TM-20-2-3, PARA 3-7, 3-8)

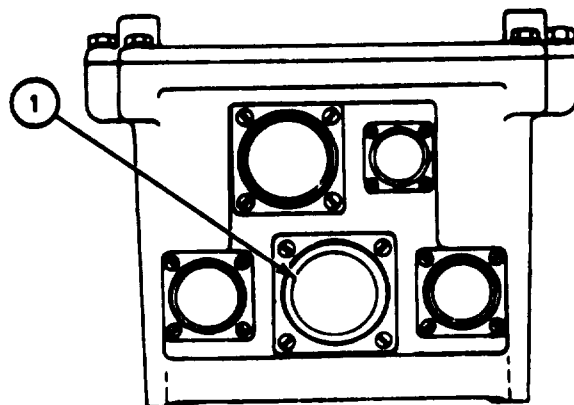

TURRET POWER AND SEARCHLIGHT RELAY BOX

3-3. MAIN GUN TROUBLESHOOTING (SHEET 1 OF 56)

- SYMPTOM:** (8) Main gun fails to fire with gunner's trigger
 (9) Main gun fails to fire with commander's trigger
 (10) Main gun fails to fire with trigger on Manual Elevation Hand Pump
 (11) Main gun fails to fire with any trigger
 (12) Firing pulse is longer than 0.5 seconds

TEST EQUIPMENT: Multimeter
 Firing circuit tester

PERSONNEL: Two

UNIT LOCATION:	FOLDOUT	CALLOUT
Turret Gun Firing Relay Box	1	22
Master Control Panel	4	4
Gunner's Control Box	1	2
Gunner's Control Handle	1	19
Loader's Safety Switch	3	6
Manual Elevation Hand Pump	1	13
Commander's Control Handle	2	12
Blasting Machine	1	15
Safety Relay Switch	1	12
Gunner's Dome Light	1	1
Turret Power and Searchlight Relay Box	1	9
Turret Electrical Slipring	3	5
Breech Ring	3	4
Gun Quick Disconnect	1	20

- REFERENCES:** (1) TM 9-2350-222-20-2-3 for removal and replacement of components
 (2) ETM 643-091-9400R/JPG for procedures to:
 Use multimeter
 Disconnect electrical connectors
 (3) TM 9-2350-222-10 for procedures to:
 Remove ammunition
 Traverse turret

EQUIPMENT CONDITION: Vehicle parked, power off.

3-3. MAIN GUN FIRING TROUBLESHOOTING (SHEET 2 OF 56)

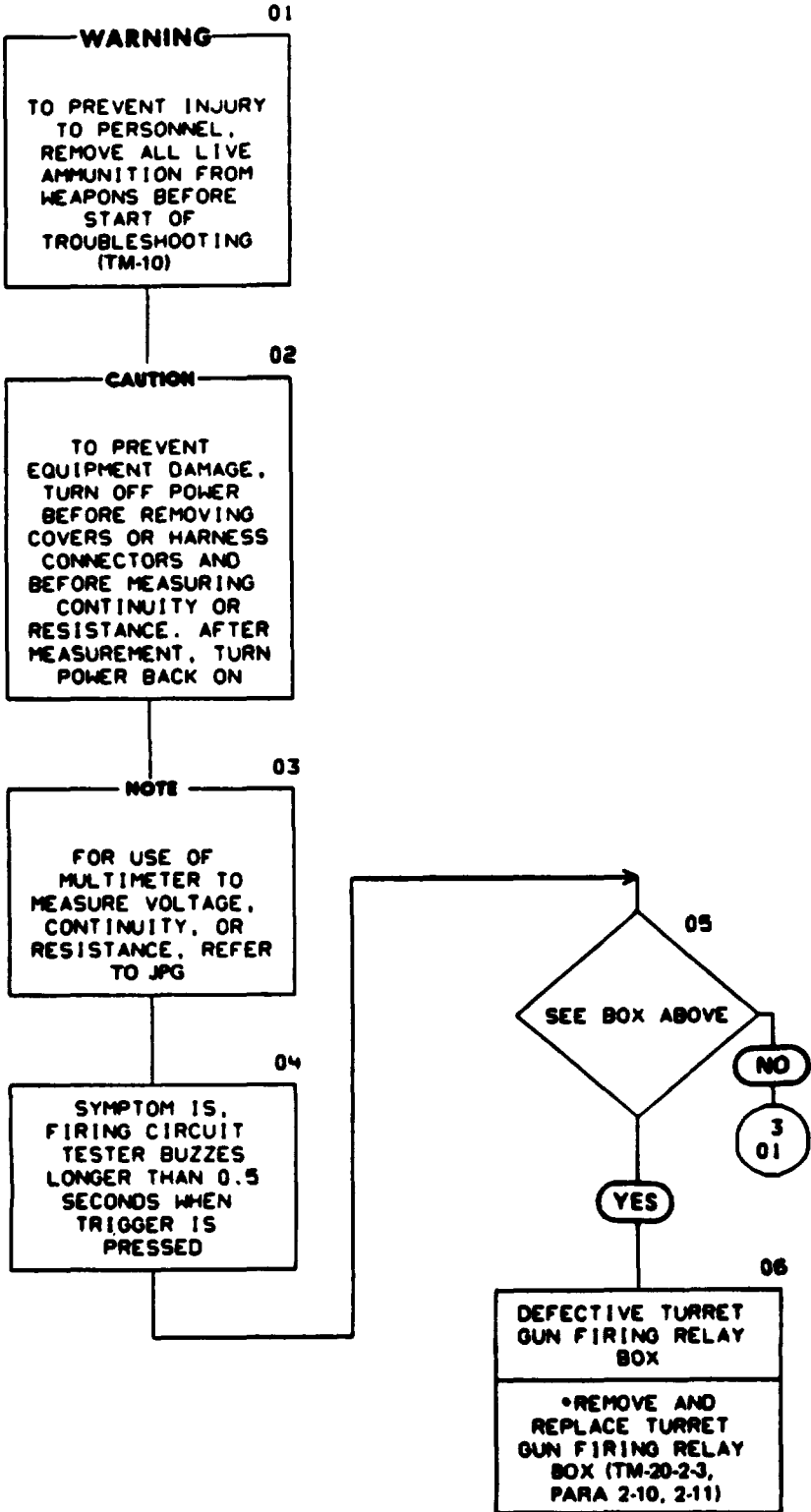

3-3. MAIN GUN FIRING TROUBLESHOOTING (SHEET 3 OF 56)

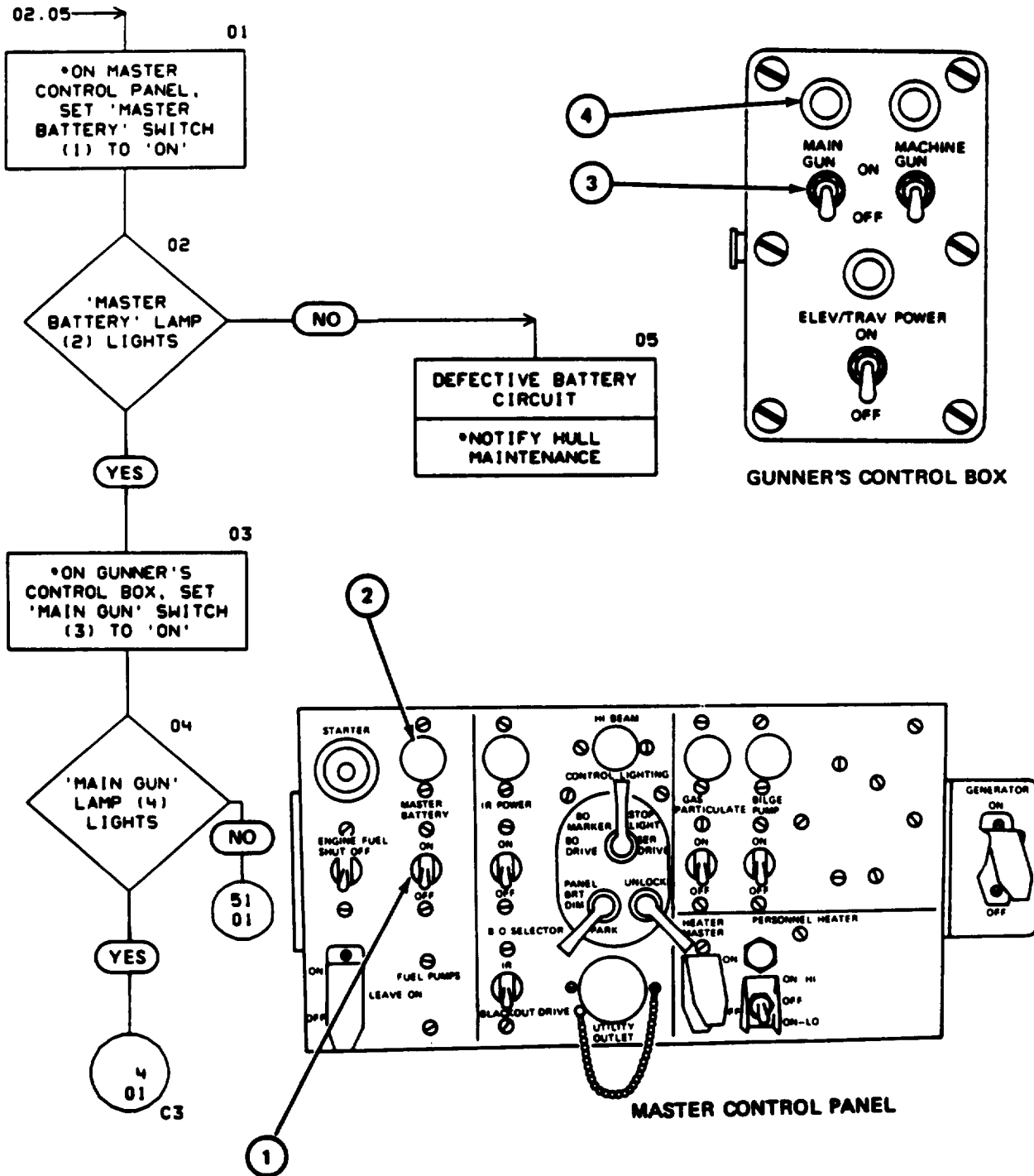

3-3. MAIN GUN FIRING TROUBLESHOOTING (SHEET 4 OF 56)

03.04 →

01

INSTALL FIRING CIRCUIT TESTER

*GRASP BREECH OPERATING HANDLE (1) WITH RIGHT HAND. PRESS PLUNGER (2). PULL HANDLE (1) STRAIGHT OUT AND SWING DOWNWARD UNTIL BREECHBLOCK IS FULLY OPEN

*RELEASE PLUNGER (2). SWING HANDLE (1) UPWARD AND PUSH FORWARD UNTIL IT LATCHES

*PUT FIRING CIRCUIT TESTER (3) IN BREECH CHAMBER (TM-10)

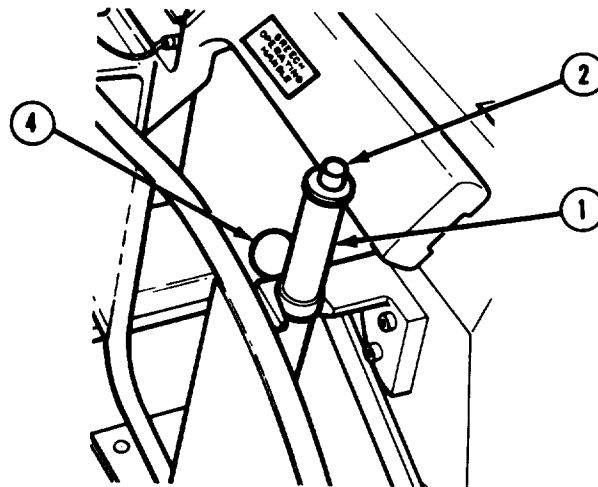

BREECHLOCK RELEASE LEVER AND BREECH OPERATING HANDLE

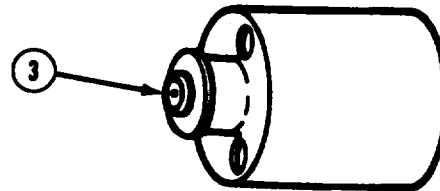

FIRING CIRCUIT TESTER

02

WARNING

BE SURE THAT BREECH OPERATING HANDLE IS LATCHED BEFORE CLOSING BREECH. IF NOT LATCHED, HANDLE WILL SPRING UP VIOLENTLY WHEN BREECH IS CLOSED.

03

*PULL BREECHBLOCK RELEASE LEVER (4) UPWARD TO CLOSE BREECH

*SET LOADER'S SAFETY SWITCH (5) TO 'FIRE'

EARLY MODEL

HARNES CONNECTORS 113B, 113C, AND 113G

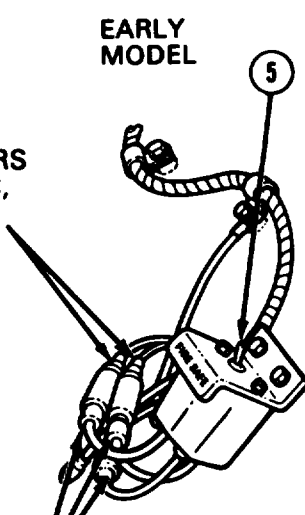

LOADER'S SAFETY SWITCH CONNECTORS 113B, 113C, AND 113G

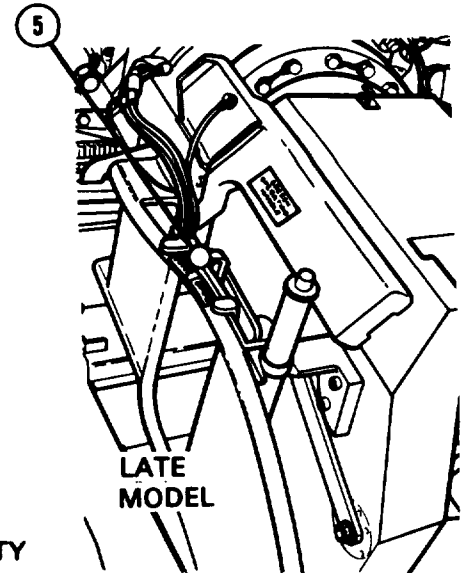

LATE MODEL

LOADER'S SAFETY SWITCH

3-3. MAIN GUN FIRING TROUBLESHOOTING (SHEET 5 OF 56)

04.03 →

01

NOTE

FIRING CIRCUIT IS NOT OPERATING NORMALLY IF FIRING CIRCUIT TESTER BUZZES LONGER THAN 0.5 SECONDS WITH TRIGGER PRESSED. IF YOU SEE THIS PROBLEM WHILE CHECKING TRIGGER CIRCUITS IN FOLLOWING STEPS, IGNORE IT AND GO ON UNTIL YOU HAVE FINISHED THIS PRECEDURE. THEN REPEAT THIS PROCEDURE. THEN REPEAT THIS PROCEDURE USING THE FOLLOWING SYMPTOM, FIRING CIRCUIT TESTER BUZZES LONGER THAN 0.5 SECONDS WHEN TRIGGER IS PRESSED.

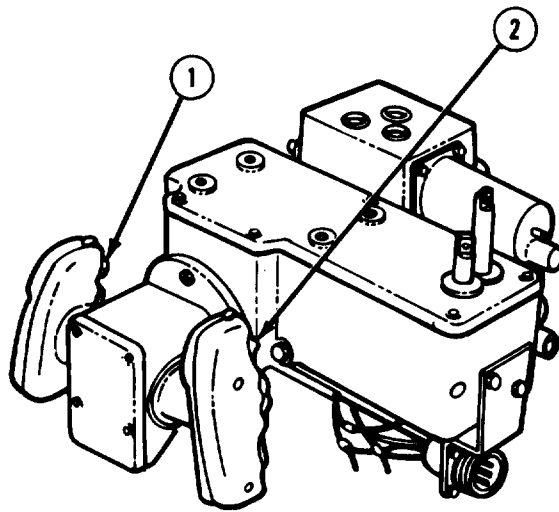

GUNNER'S CONTROL ASSEMBLY

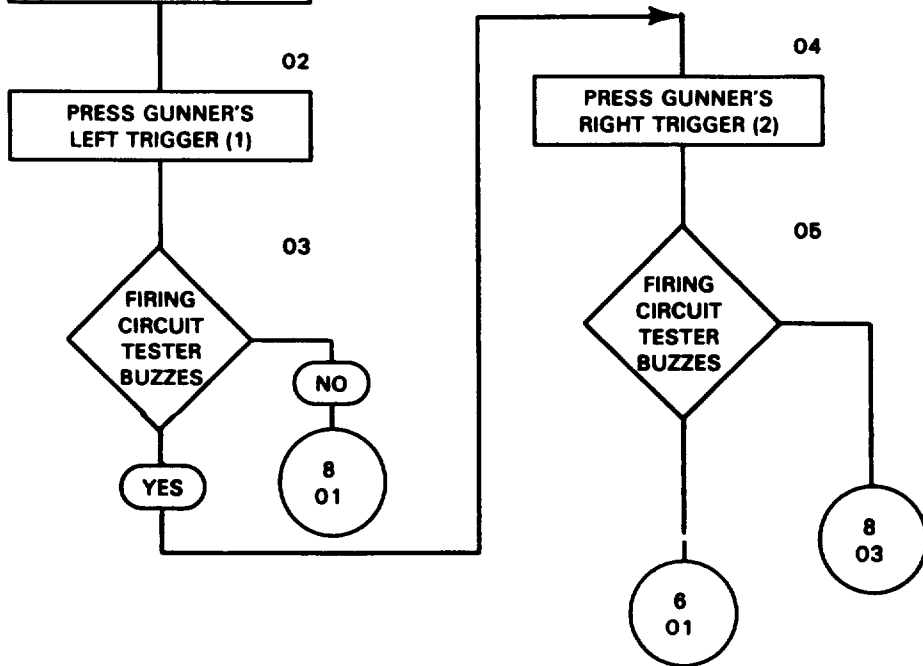

3-3. MAIN GUN FIRING TROUBLESHOOTING (SHEET 6 of 56)

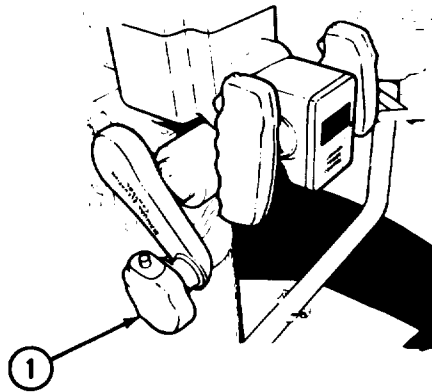
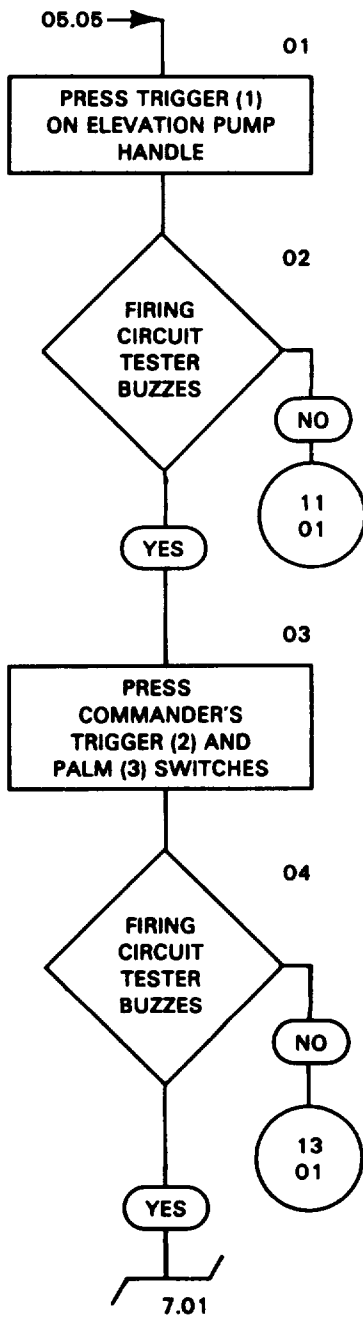

MANUAL ELEVATION PUMP HANDLE

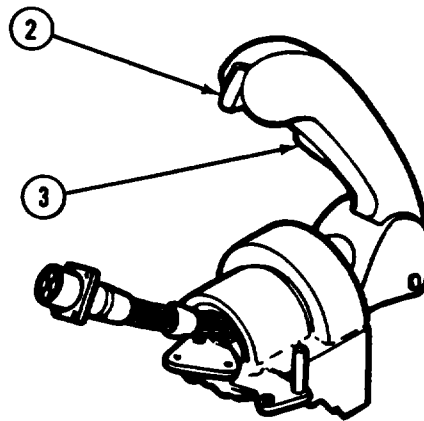

COMMANDER'S CONTROL HANDLE

3-3. MAIN GUN FIRING TROUBLESHOOTING (SHEET 7 OF 56)

06.04 →

01

DEFECTIVE AMMUNITION

*SET LOADER'S SAFETY SWITCH (1) TO 'SAFE'

*SET 'MASTER BATTERY' SWITCH TO 'OFF'

*ON GUNNER'S CONTROL BOX, SET 'MAIN GUN' SWITCH (2) TO 'OFF'

*GRASP BREECH OPERATING HANDLE (3) WITH RIGHT HAND. PRESS PLUNGER (4). PULL HANDLE (3) STRAIGHT OUT AND SWING DOWNWARD UNTIL BREECHBLOCK IS FULLY OPEN

*RELEASE PLUNGER (4). SWING HANDLE (3) UPWARD AND PUSH FORWARD UNTIL IT LATCHES

*REMOVE FIRING CIRCUIT TESTER (5) FROM BREECH

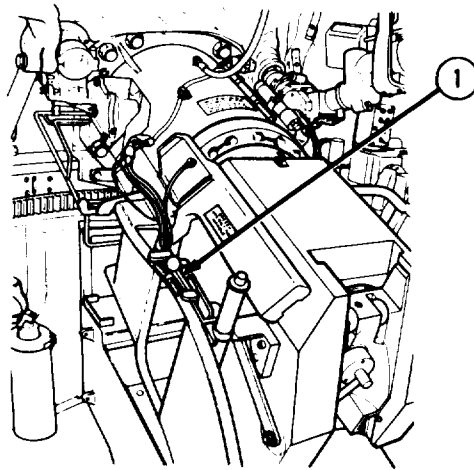

LOADER'S SAFETY SWITCH
LATE MODEL

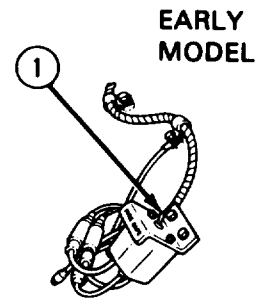

EARLY MODEL
LOADER'S SAFETY SWITCH

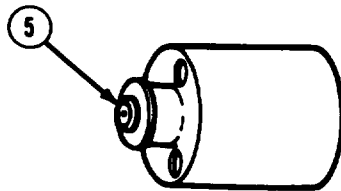

FIRING CIRCUIT TESTER

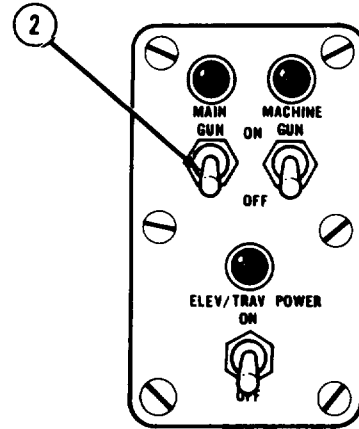

GUNNER'S CONTROL BOX

02

WARNING

BE SURE THAT BREECH OPERATING HANDLE IS LATCHED BEFORE CLOSING BREECH. IF NOT LATCHED, HANDLE WILL SPRING UP VIOLENTLY WHEN BREECH IS CLOSED.

07.02 →

03

*PULL BREECHBLOCK RELEASE LEVER (6) UPWARD TO CLOSE BREECH

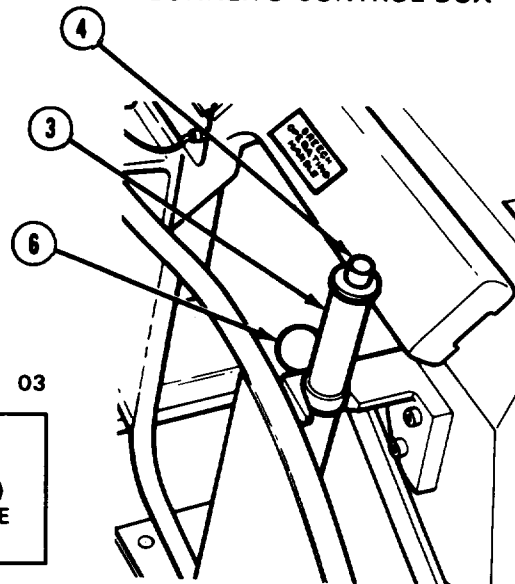

BREECHLOCK RELEASE LEVER AND BREECH OPERATING HANDLE

7.03

3-3. MAIN GUN FIRING TROUBLESHOOTING (SHEET 8 OF 56)

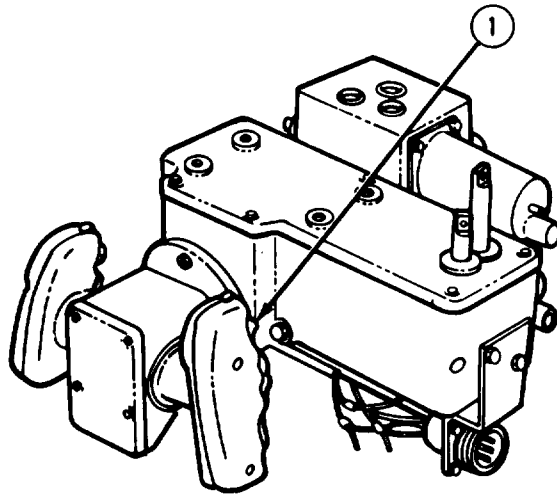
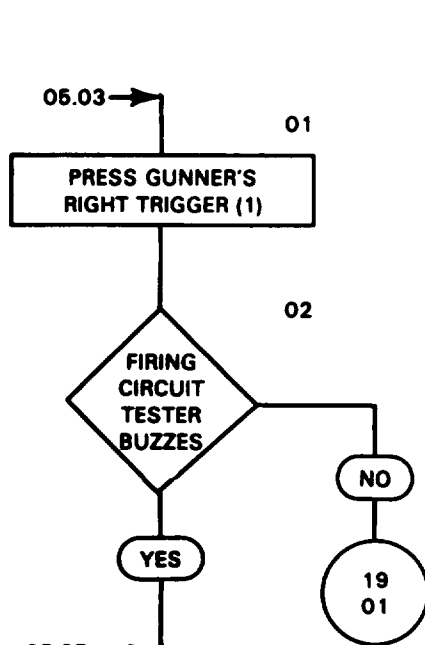

GUNNER'S CONTROL ASSEMBLY

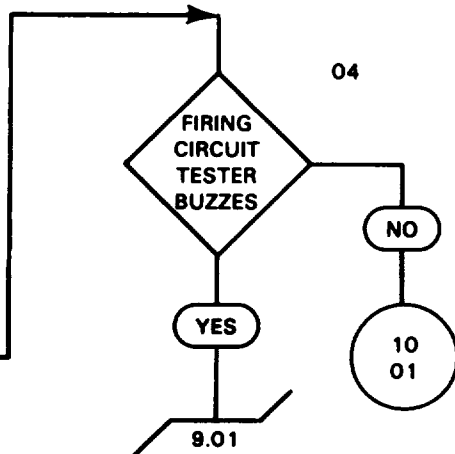
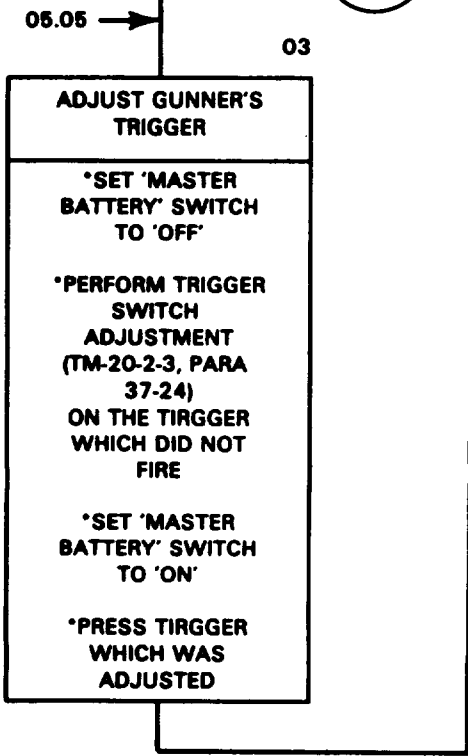

3-3. MAIN GUN FIRING TROUBLESHOOTING (SHEET 9 OF 56)

08.04 →

01

FAULT CORRECTED

- *SET LOADER'S SAFETY SWITCH (1) TO 'SAFE'
- *SET 'MASTER BATTERY' SWITCH TO 'OFF'
- *ON GUNNER'S CONTROL BOX, SET 'MAIN GUN' SWITCH (2) TO 'OFF'
- *GRASP BREECH OPERATING HANDLE (3) WITH RIGHT HAND. PRESS PLUNGER (4). PULL HANDLE (3) STRAIGHT OUT AND SWING DOWNWARD UNTIL THE BREECHBLOCK IS FULLY OPEN
- *RELEASE PLUNGER (4). SWING HANDLE (3) UPWARD AND PUSH FORWARD UNTIL IT LATCHES
- *REMOVE FIRING CIRCUIT TESTER (5) FROM BREECH

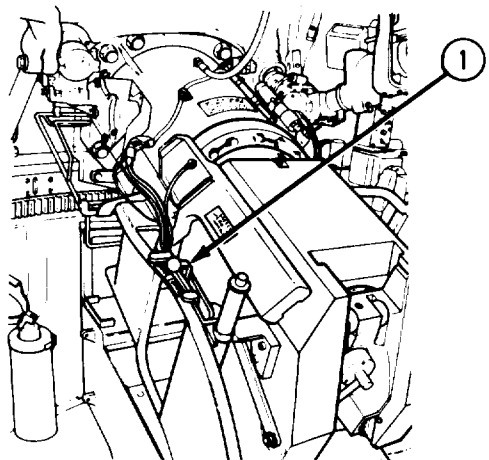

LOADER'S SAFETY SWITCH
LATE MODEL

EARLY MODEL

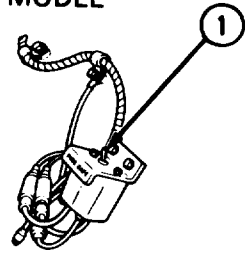

LOADER'S SAFETY SWITCH

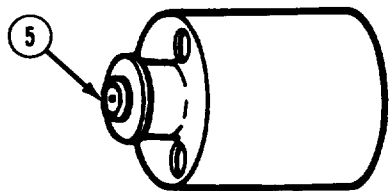

FIRING CIRCUIT TESTER

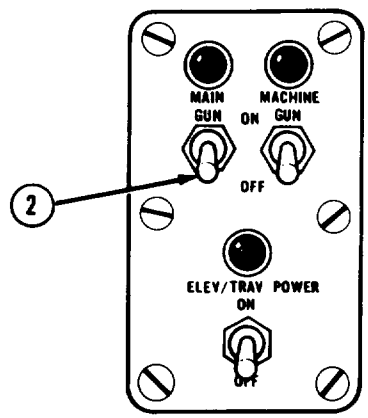

GUNNER'S CONTROL BOX

02

WARNING

BE SURE THAT BREECH OPERATING HANDLE IS LATCHED BEFORE CLOSING BREECH. IF NOT LATCHED, HANDLE WILL SPRING UP VIOLENTLY WHEN BREECH IS CLOSED.

03

*PULL BREECHBLOCK RELEASE LEVER (6) UPWARD TO CLOSE BREECH

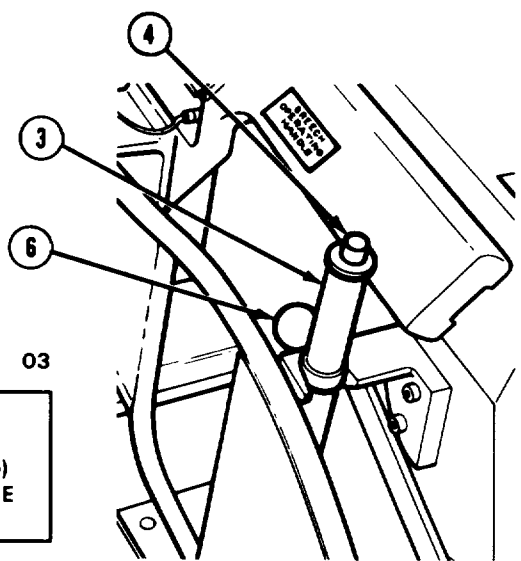

BREECHLOCK RELEASE LEVER AND BREECH OPERATING HANDLE

3-3. MAIN GUN FIRING TROUBLESHOOTING (SHEET 10 OF 56)

08.04 →

01

REMOVE FIRING
CIRCUIT TESTER

*SET LOADER'S
SAFETY SWITCH (1)
TO 'SAFE'

*SET 'MASTER
BATTERY' SWITCH
TO 'OFF'

*ON GUNNER'S
CONTROL BOX, SET
'MAIN GUN' SWITCH
(2) TO 'OFF'

*GRASP BREECH
OPERATING HANDLE
(3) WITH RIGHT
HAND. PRESS
PLUNGER (4). PULL
HANDLE (3)
STRAIGHT OUT AND
SWING DOWNWARD
UNTIL BREECHBLOCK
IS FULLY OPEN

*RELEASE PLUNGER
(4).
SWING HANDLE (3)
UPWARD AND PUSH
FORWARD UNTIL IT
LATCHES

*REMOVE FIRING
CIRCUIT TESTER
FROM BREECH (5)

02

WARNING

BE SURE THAT
BREECH OPERATING
HANDLE IS LATCHED
BEFORE CLOSING
BREECH. IF NOT
LATCHED, HANDLE
WILL SPRING UP
VIOLENTLY WHEN
BREECH IS CLOSED.

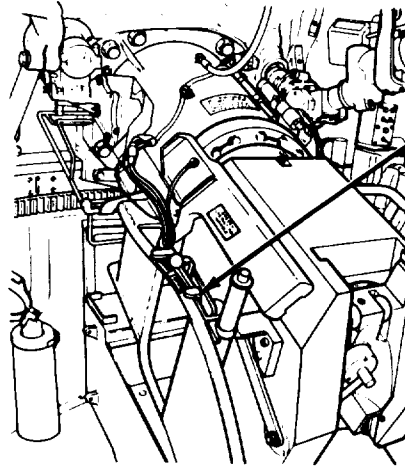

LOADER'S SAFETY SWITCH
LATE MODEL

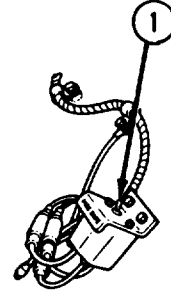

EARLY
MODEL

LOADER'S SAFETY SWITCH

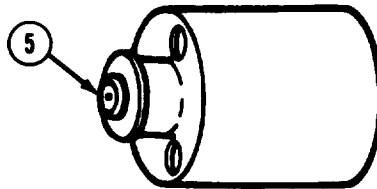

FIRING CIRCUIT TESTER

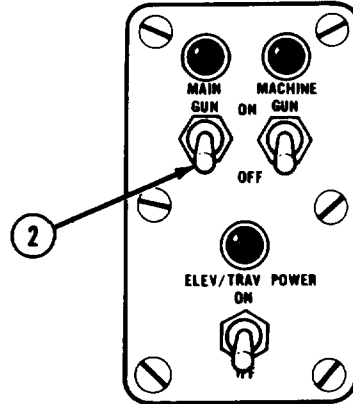

GUNNER'S CONTROL BOX

03

*PULL
BREECHBLOCK
RELEASE LEVER (6)
UPWARD TO CLOSE
BREECH

04

DEFECTIVE
GUNNER'S CONTROL
ASSEMBLY

*REMOVE AND
REPLACE GUNNER'S
CONTROL
ASSEMBLY
(TM-20-2-3,
PARA 37-18, 37-19)

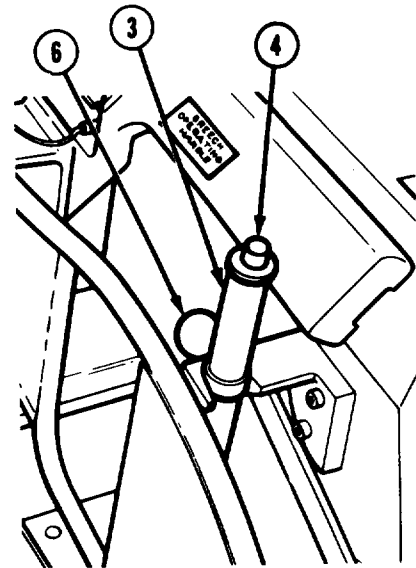

BREECHLOCK RELEASE LEVER AND
BREECH OPERATING HANDLE

3-3. MAIN GUN FIRING TROUBLESHOOTING (SHEET 11 OF 56)

06.02 →

01

REMOVE FIRING
CIRCUIT TESTER

*SET LOADER'S
SAFETY SWITCH (1)
TO 'SAFE'

*SET 'MASTER
BATTERY' SWITCH
TO 'OFF'

*ON GUNNER'S
CONTROL BOX, SET
'MAIN GUN' SWITCH
(2) TO 'OFF'

*GRASP BREECH
OPERATING HANDLE
(3) WITH RIGHT
HAND. PRESS
PLUNGER (4). PULL
HANDLE (3)
STRAIGHT OUT AND SWING
DOWNWARD UNTIL
THE BREECHBLOCK
IS FULLY OPEN

*RELEASE PLUNGER
(4). SWING HANDLE
(3) UPWARD AND
PUSH
FORWARD UNTIL IT
LATCHES

*REMOVE FIRING
CIRCUIT TESTER
(5) FROM BREECH

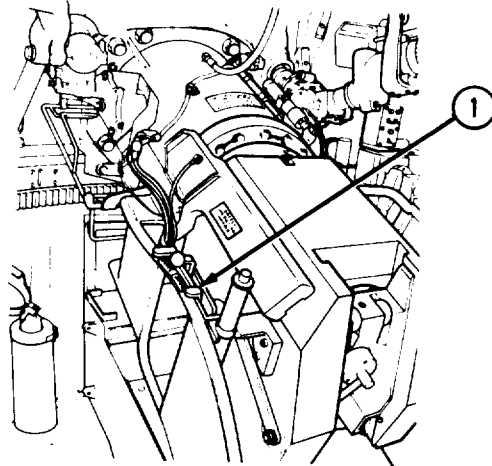

LOADER'S SAFETY SWITCH
LATE MODEL

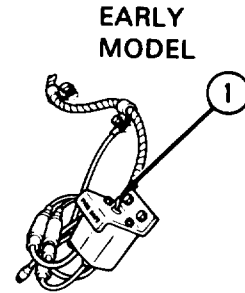

EARLY
MODEL
LOADER'S SAFETY SWITCH

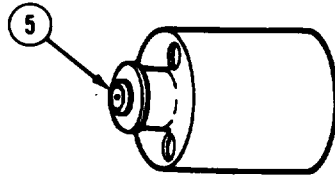

FIRING CIRCUIT TESTER

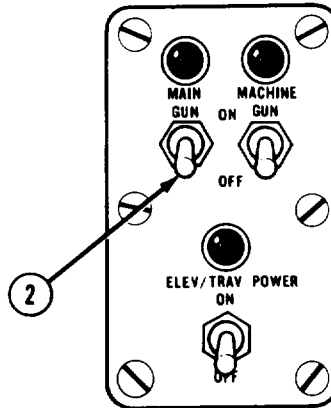

GUNNER'S CONTROL BOX

WARNING

02

BE SURE THAT
BREECH OPERATING
HANDLE IS LATCHED
BEFORE CLOSING
BREECH. IF NOT
LATCHED, HANDLE
WILL SPRING UP
VIOLENTLY WHEN
BREECH IS CLOSED.

*PULL
BREECHBLOCK
RELEASE LEVER (6)
UPWARD TO CLOSE
BREECH

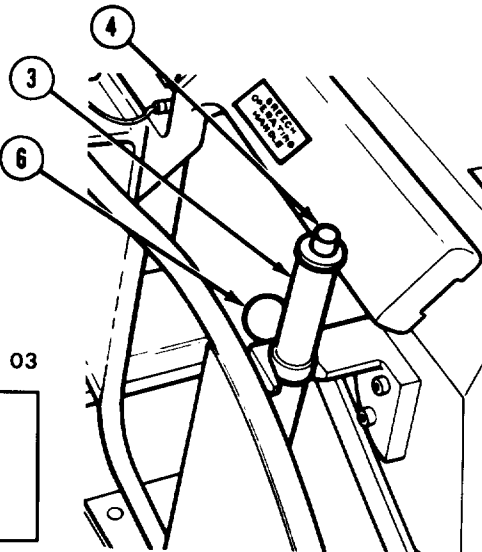

BREECHLOCK RELEASE LEVER AND
BREECH OPERATING HANDLE

12
01

3-3. MAIN GUN FIRING TROUBLESHOOTING (SHEET 12 OF 58)

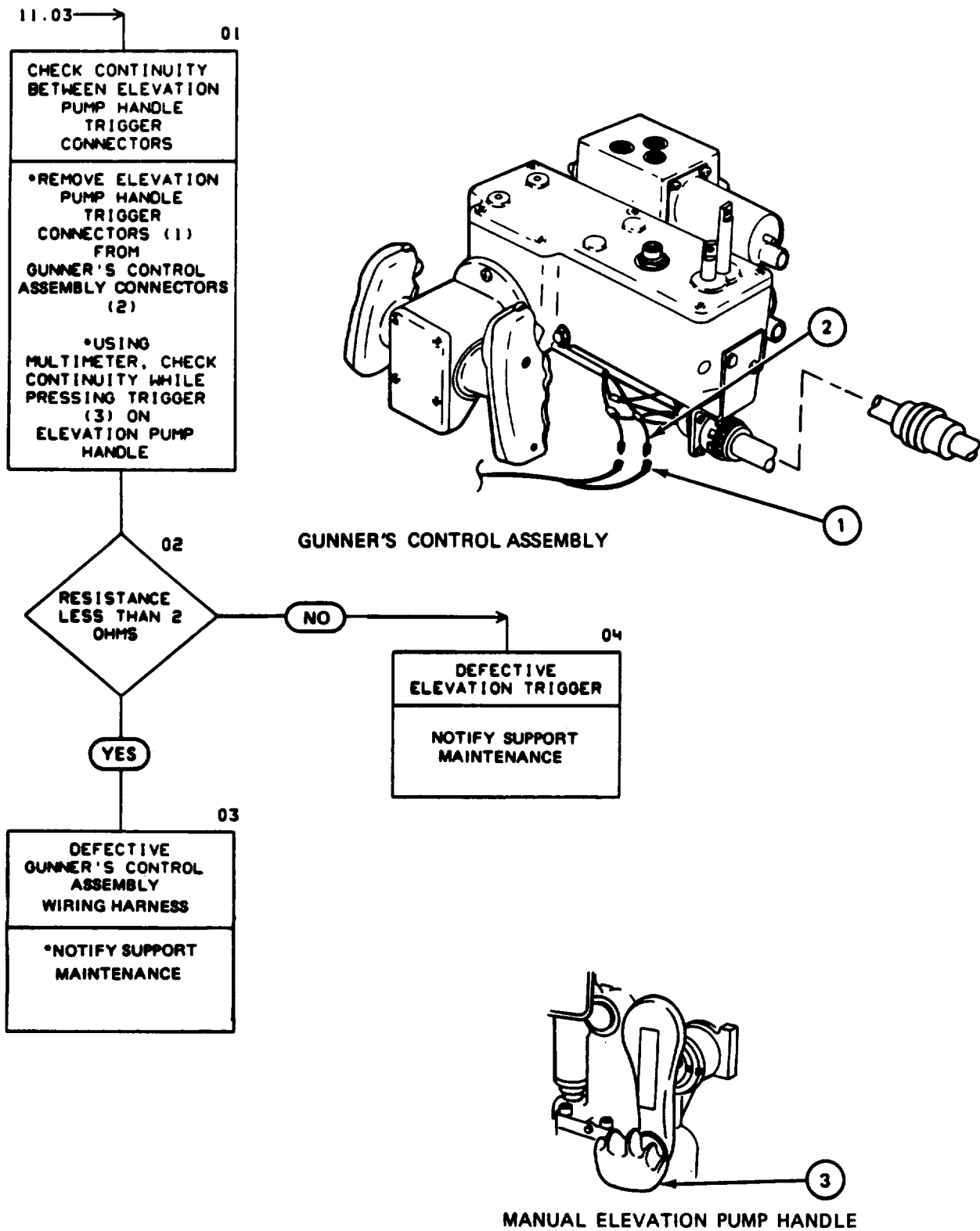

3-3. MAIN GUN FIRING TROUBLESHOOTING (SHEET 13 OF 56)

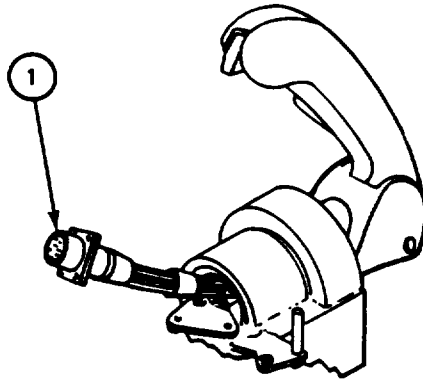
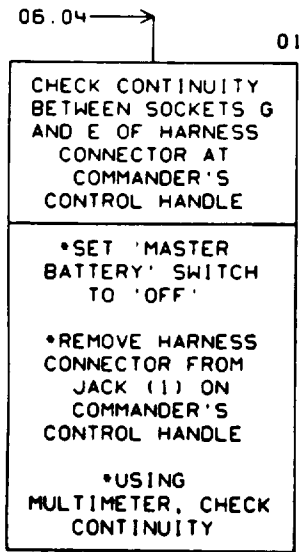

COMMANDER'S CONTROL HANDLE

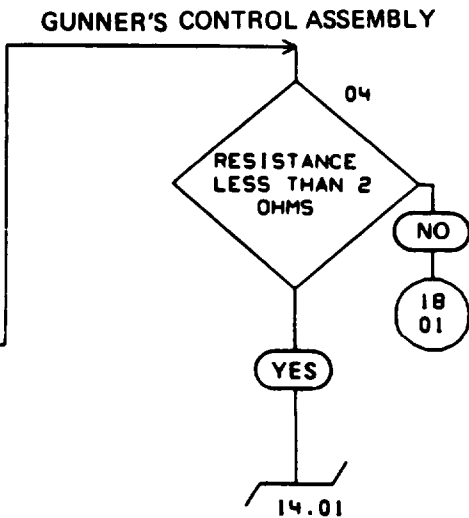
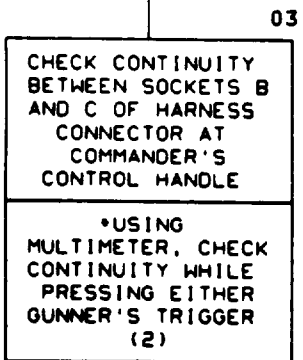
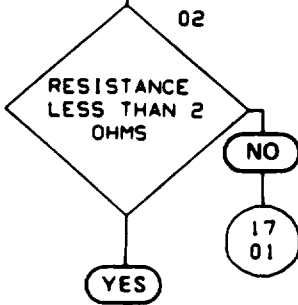
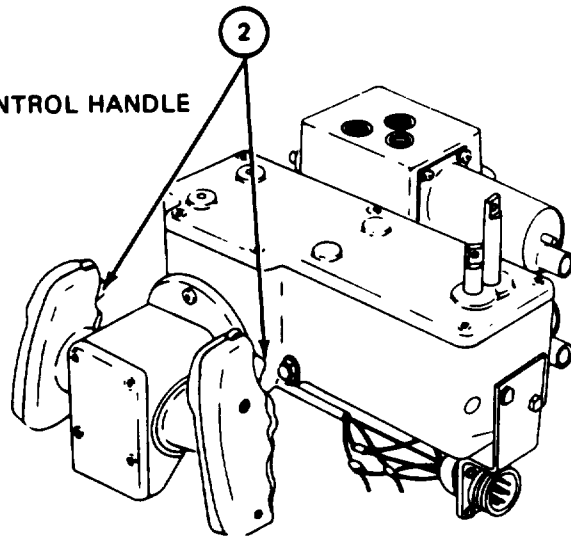

3-3. MAIN GUN FIRING TROUBLESHOOTING (SHEET 14 OF 56)

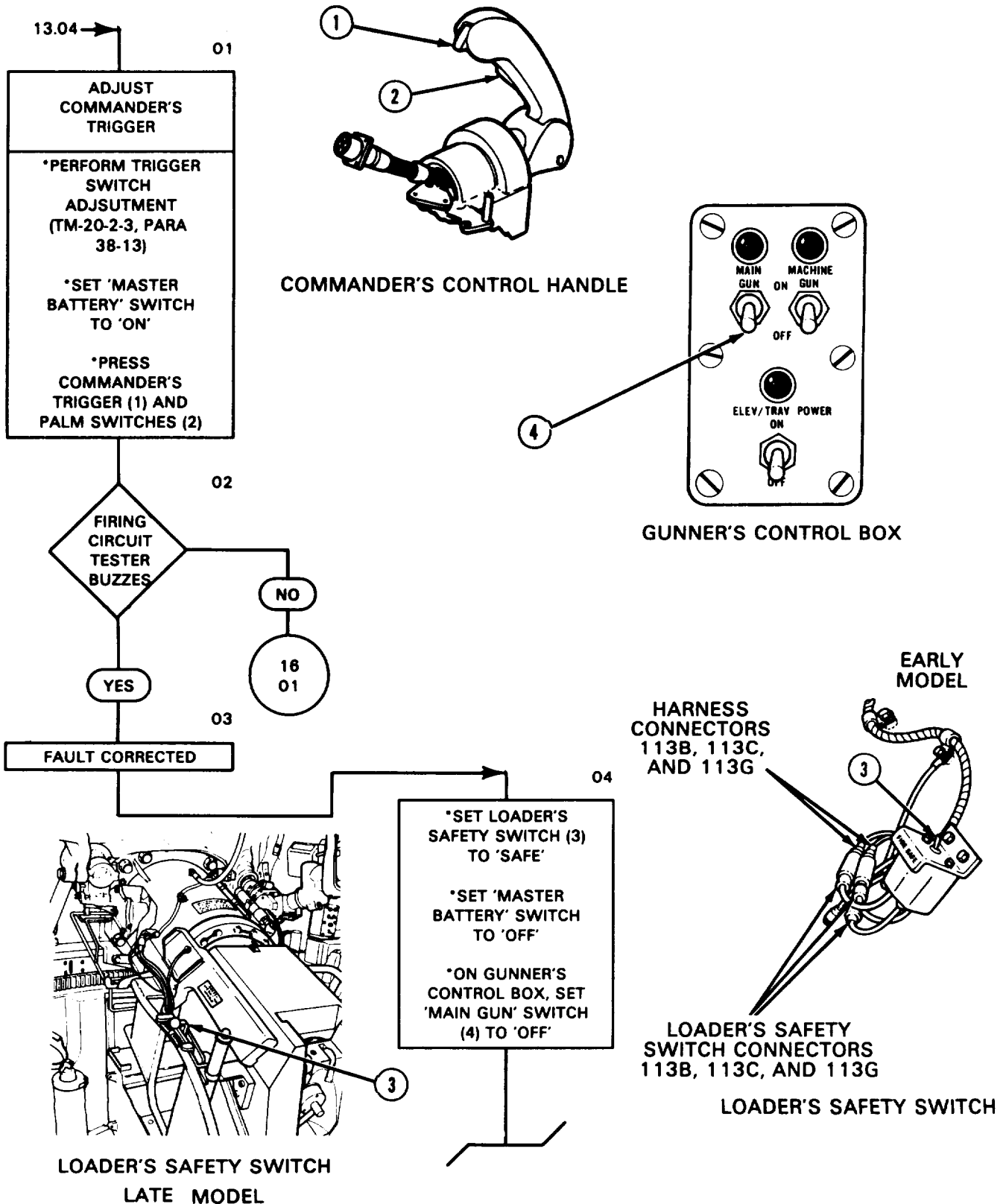

3-3. MAIN GUN FIRING TROUBLESHOOTING (SHEET 15 OF 56)

14.04 →

01

REMOVE FIRING
CIRCUIT TESTER

*GRASP BREECH
OPERATING HANDLE
(1) WITH RIGHT
HAND. PRESS
PLUNGER (2). PULL
HANDLE (1)
STRAIGHT OUT AND
SWING
DOWNWARD UNTIL
THE BREECHBLOCK
IS FULLY OPEN

*RELEASE PLUNGER
(2). SWING HANDLE
(1) UPWARD AND
PUSH
FORWARD UNTIL IT
LATCHES

*REMOVE FIRING
CIRCUIT TESTER
(3) FROM BREECH

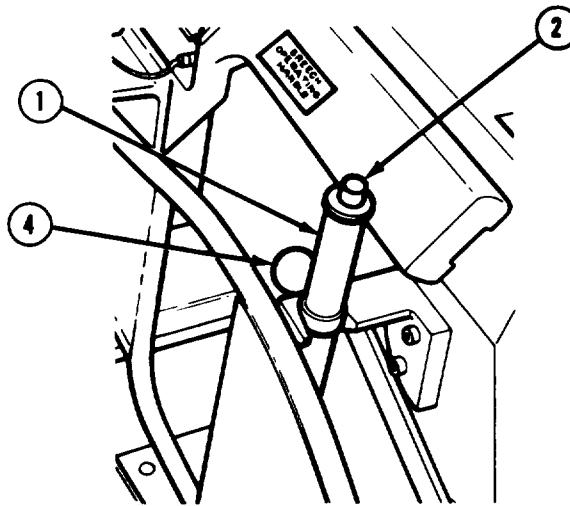

BREECHLOCK RELEASE LEVER AND
BREECH OPERATING HANDLE

WARNING

02

BE SURE THAT
BREECH OPERATING
HANDLE IS LATCHED
BEFORE CLOSING
BREECH. IF NOT
LATCHED. HANDLE
WILL SPRING UP
VIOLENTLY WHEN
BREECH IS CLOSED.

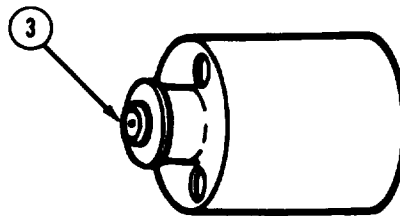

FIRING CIRCUIT TESTER

03

*PULL BREECHBLOCK
RELEASE LEVER (6)
UPWARD TO CLOSE
BREECH

3-3. MAIN GUN FIRING TROUBLESHOOTING (SHEET 16 OF 56)

14.02 →

01

REMOVE FIRING CIRCUIT TESTER

*SET LOADER'S SAFETY SWITCH (1) TO 'SAFE'

*SET 'MASTER BATTERY' SWITCH TO 'OFF'

*ON GUNNER'S CONTROL BOX, SET 'MAIN GUN' SWITCH (2) TO 'OFF'

*GRASP BREECH OPERATING HANDLE (3) WITH RIGHT HAND. PRESS PLUNGER (4). PULL HANDLE (3) STRAIGHT OUT AND SWING DOWNWARD UNTIL BREECHBLOCK IS COMPLETELY OPEN

*RELEASE PLUNGER (4). SWING HANDLE (3) UPWARD AND PUSH FORWARD UNTIL IT LATCHES

*REMOVE FIRING CIRCUIT TESTER (5) FROM BREECH

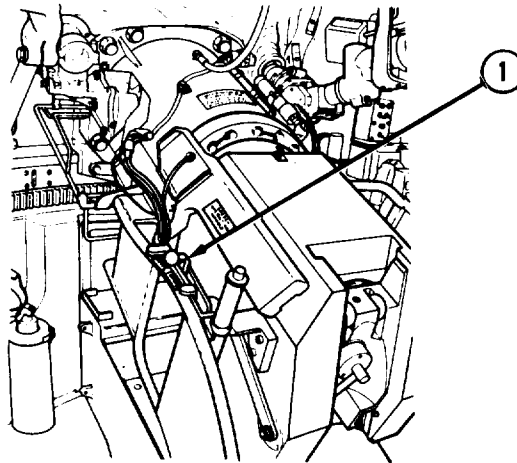

LOADER'S SAFETY SWITCH
LATE MODEL

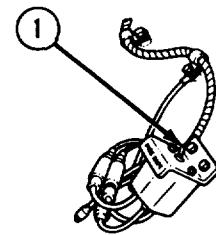

EARLY MODEL

LOADER'S SAFETY SWITCH

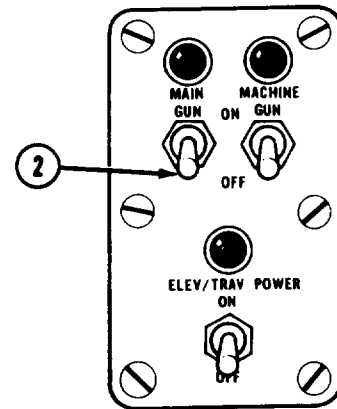

GUNNER'S CONTROL BOX

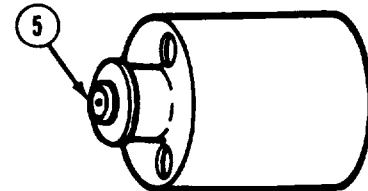

FIRING CIRCUIT TESTER

02

WARNING

BE SURE THAT BREECH OPERATING HANDLE IS LATCHED BEFORE CLOSING BREECH. IF NOT LATCHED, HANDLE WILL SPRING UP VIOLENTLY WHEN BREECH IS CLOSED.

03

*PULL BREECHBLOCK RELEASE LEVER (6) UPWARD TO CLOSE BREECH

04

DEFECTIVE COMMANDER'S CONTROL HANDLE

*REMOVE AND REPLACE COMMANDER'S CONTROL HANDLE (TM-20-2-3, PARA 38-2, 38-3)

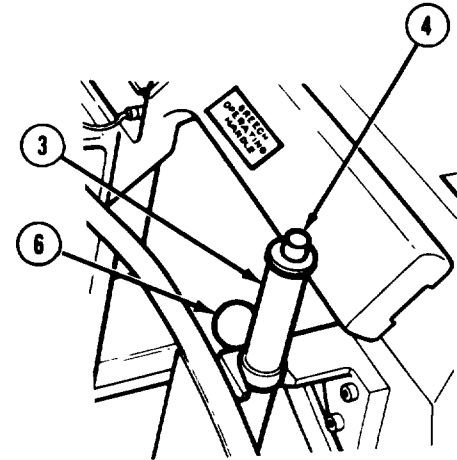

BREECHLOCK RELEASE LEVER AND BREECH OPERATING HANDLE

3-3. MAIN GUN FIRING TROUBLESHOOTING (SHEET 17 OF 56)

13.02 →

01

REMOVE FIRING CIRCUIT TESTER

*SET LOADER'S SAFETY SWITCH (1) TO 'SAFE'

*ON GUNNER'S CONTROL BOX, SET 'MAIN GUN' SWITCH (2) TO 'OFF'

*GRASP BREECH OPERATING HANDLE (3) WITH RIGHT HAND. PRESS PLUNGER (4). PULL HANDLE (3) STRAIGHT OUT AND SWING DOWNWARD UNTIL BREECHBLOCK IS COMPLETELY OPEN

*RELEASE PLUNGER (4). SWING HANDLE (3) UPWARD AND PUSH FORWARD UNTIL IT LATCHES

*REMOVE FIRING CIRCUIT TESTER (5) FROM BREECH

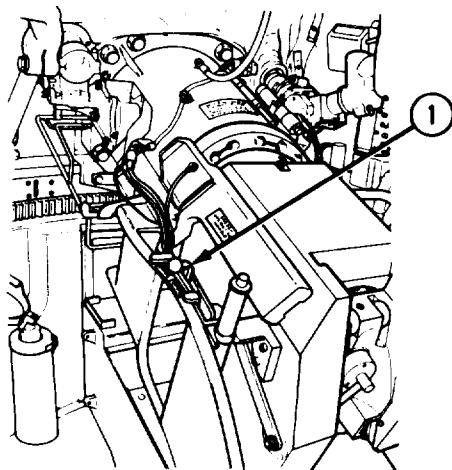

LOADER'S SAFETY SWITCH LATE MODEL

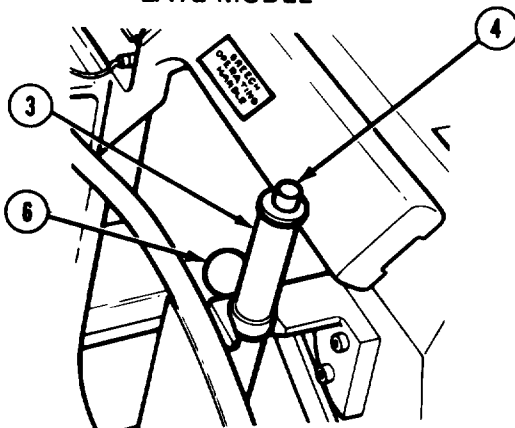

BREECHLOCK RELEASE LEVER AND BREECH OPERATING HANDLE

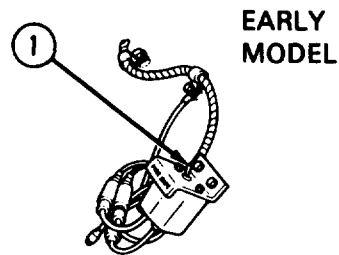

EARLY MODEL

LOADER'S SAFETY SWITCH

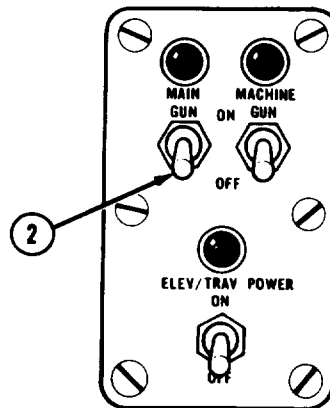

GUNNER'S CONTROL BOX

02

WARNING

BE SURE THAT BREECH OPERATING HANDLE IS LATCHED BEFORE CLOSING BREECH. IF NOT LATCHED, HANDLE WILL SPRING UP VIOLENTLY WHEN BREECH IS CLOSED.

03

*PULL BREECHBLOCK RELEASE LEVER (6) UPWARD TO CLOSE BREECH

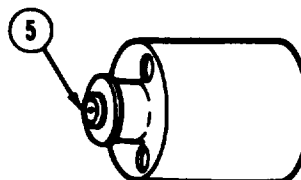

FIRING CIRCUIT TESTER

04

DEFECTIVE WIRING HARNESS

*NOTIFY SUPPORT MAINTENANCE

3-3. MAIN GUN FIRING TROUBLESHOOTING (SHEET 18 OF 56)

13.04 → 01

REMOVE FIRING CIRCUIT TESTER

*SET LOADER'S SAFETY SWITCH (1) TO 'SAFE'

*ON GUNNER'S CONTROL BOX, SET 'MAIN GUN' SWITCH (2) TO 'OFF'

*GRASP BREECH OPERATING HANDLE (3) WITH RIGHT HAND. PRESS PLUNGER (4). PULL HANDLE (3) STRAIGHT OUT AND SWING DOWNWARD UNTIL BREECHBLOCK IS COMPLETELY OPEN

*RELEASE PLUNGER (4) SWING HANDLE (3) UPWARD AND PUSH FORWARD UNTIL IT LATCHES

*REMOVE FIRING CIRCUIT TESTER (5) FROM BREECH

02

WARNING

BE SURE THAT BREECH OPERATING HANDLE IS LATCHED BEFORE CLOSING BREECH. IF NOT LATCHED, HANDLE WILL SPRING UP VIOLENTLY WHEN BREECH IS CLOSED.

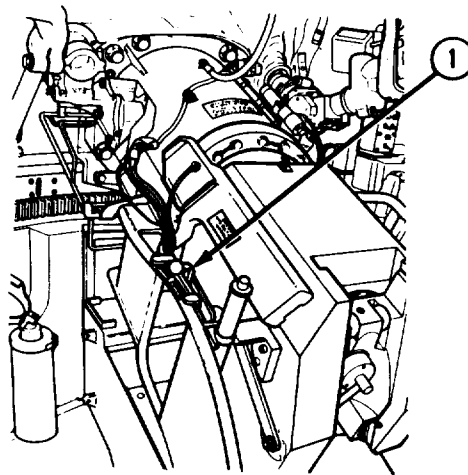

LOADER'S SAFETY SWITCH LATE MODEL

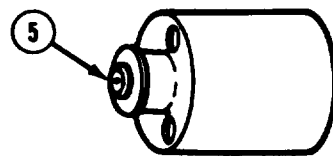

FIRING CIRCUIT TESTER

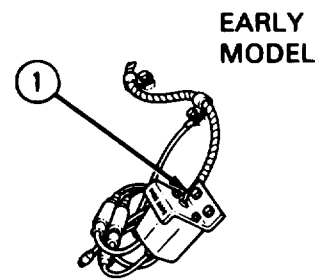

EARLY MODEL
LOADER'S SAFETY SWITCH

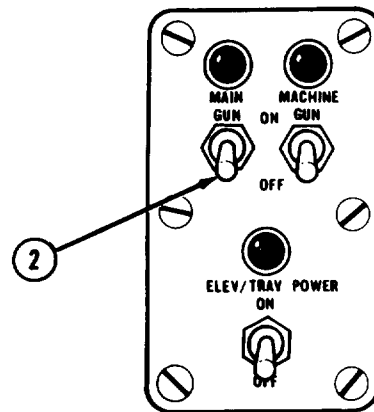

GUNNER'S CONTROL BOX

03

*PULL BREECHBLOCK RELEASE LEVER (6) UPWARD TO CLOSE BREECH

04

TURRET CONTROL WIRING HARNESS IS DEFECTIVE BETWEEN SOCKET C AT COMMANDER'S CONTROL HANDLE AND SOCKET G AT GUNNER'S CONTROL BOX

*NOTIFY SUPPORT MAINTENANCE

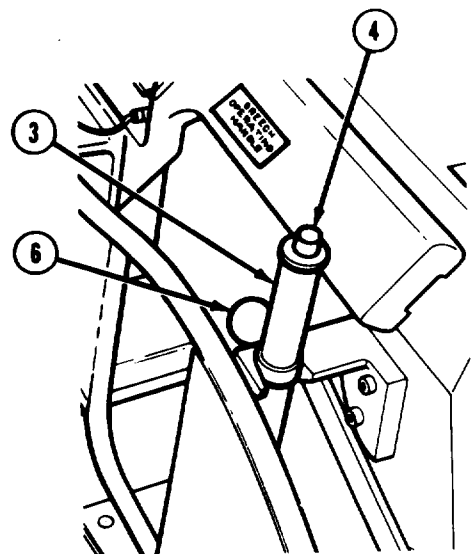

BREECHLOCK RELEASE LEVER AND BREECH OPERATING HANDLE

3-3. MAIN GUN FIRING TROUBLESHOOTING (SHEET 19 OF 56)

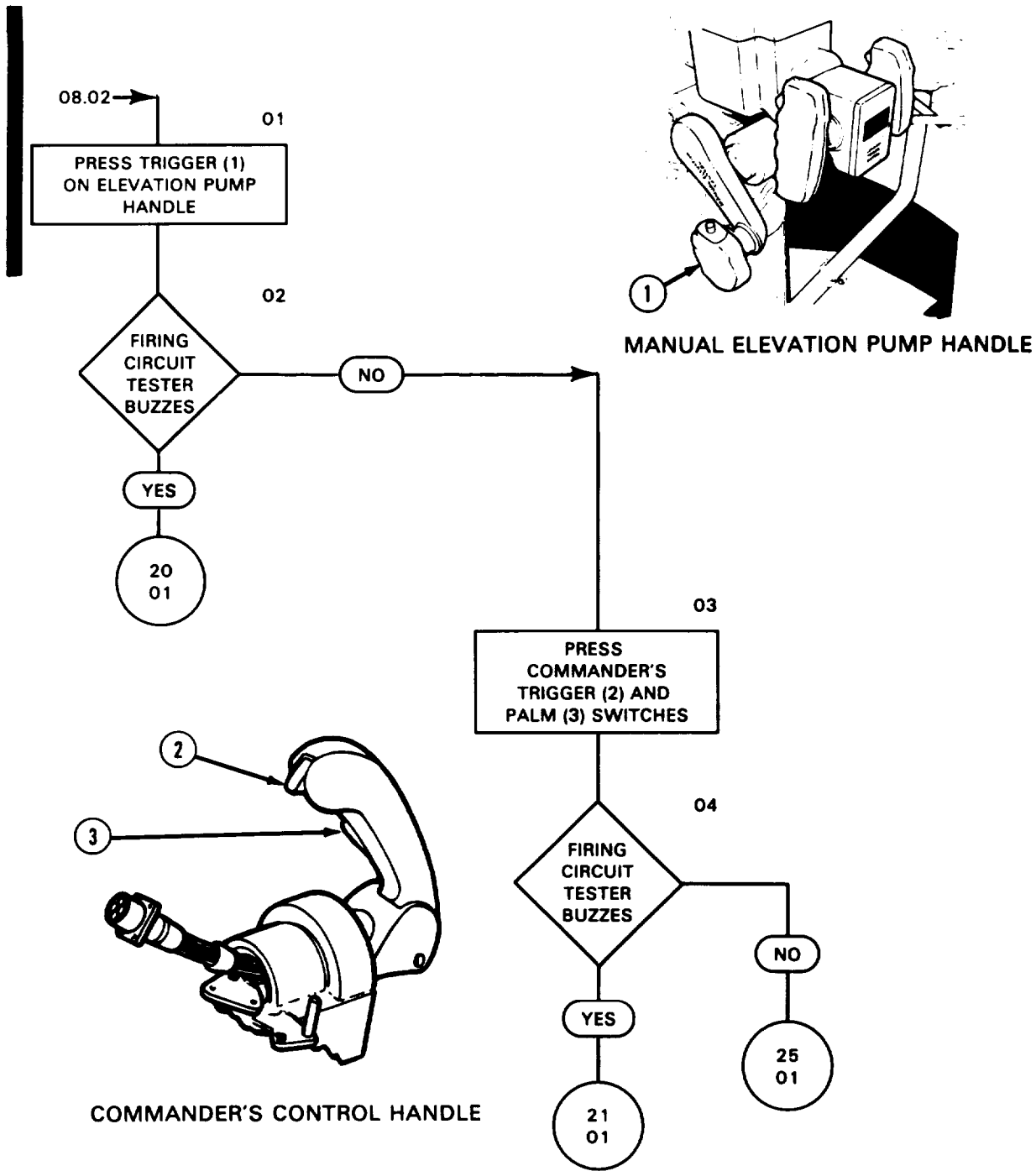

3-3. MAIN GUN FIRING TROUBLESHOOTING (SHEET 20 OF 56)

19.02 →

01

REMOVE FIRING CIRCUIT TESTER

*SET LOADER'S SAFETY SWITCH (1) TO 'SAFE'

*SET 'MASTER BATTERY' SWITCH TO 'OFF'

*ON GUNNER'S CONTROL BOX, SET 'MAIN GUN' SWITCH (2) TO 'OFF'

*GRASP BREECH OPERATING HANDLE (3) WITH RIGHT HAND. PRESS PLUNGER (4). PULL HANDLE (3) STRAIGHT OUT AND SWING DOWNWARD UNTIL BREECHBLOCK IS FULLY OPEN

*RELEASE PLUNGER (4). SWING HANDLE (3) UPWARD AND PUSH FORWARD UNTIL IT LATCHES

*REMOVE FIRING CIRCUIT TESTER (5) FROM BREECH

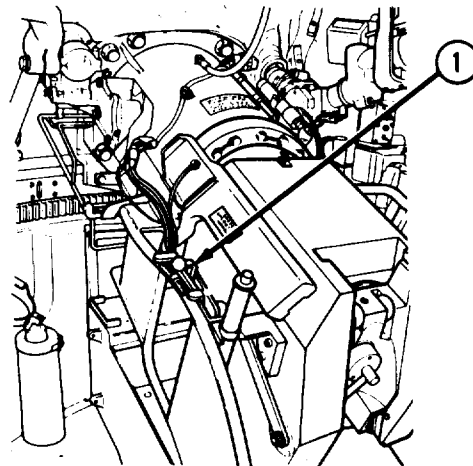

LOADER'S SAFETY SWITCH
LATE MODEL

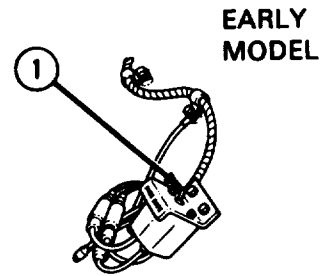

EARLY MODEL
LOADER'S SAFETY SWITCH

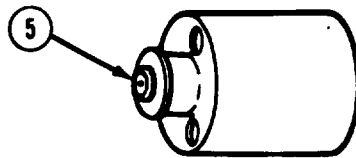

FIRING CIRCUIT TESTER

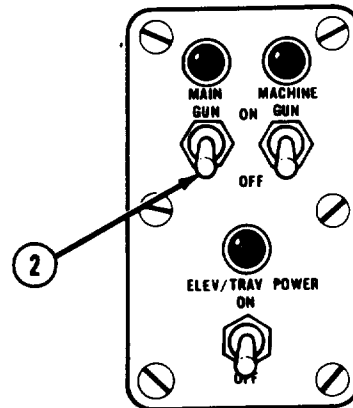

GUNNER'S CONTROL BOX

02

WARNING

BE SURE THAT BREECH OPERATING HANDLE IS LATCHED BEFORE CLOSING BREECH. IF NOT LATCHED, HANDLE WILL SPRING UP VIOLENTLY WHEN BREECH IS CLOSED.

03

*PULL BREECHBLOCK RELEASE LEVER (8) UPWARD TO CLOSE BREECH

04

DEFECTIVE GUNNER'S CONTROL ASSEMBLY

*REMOVE AND REPLACE GUNNER'S CONTROL ASSEMBLY (TM-20-2-3, PARA 37-18, 37-19)

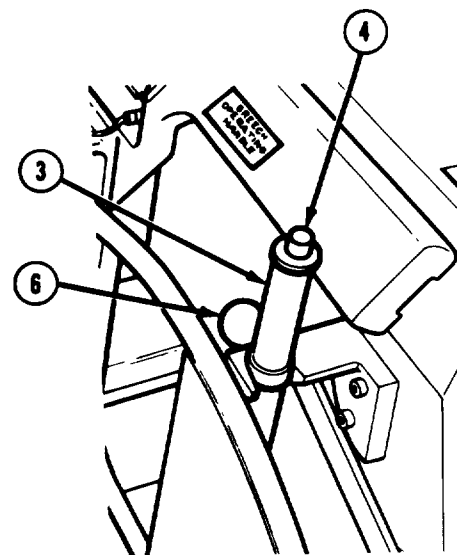

BREECHLOCK RELEASE LEVER AND BREECH OPERATING HANDLE

3-3. MAIN GUN FIRING TROUBLESHOOTING (SHEET 21 OF 56)

19.04 →

01

REMOVE FIRING CIRCUIT TESTER

*SET LOADER'S SAFETY SWITCH (1) TO 'SAFE'

*SET 'MASTER BATTERY' SWITCH TO 'OFF'

*ON GUNNER'S CONTROL BOX, SET 'MAIN GUN' SWITCH (2) TO 'OFF'

*GRASP BREECH OPERATING HANDLE (3) WITH RIGHT HAND. PRESS PLUNGER (4). PULL HANDLE (5) STRAIGHT OUT AND SWING DOWNWARD UNTIL THE BREECHBLOCK IS FULLY OPEN

*RELEASE PLUNGER (4). SWING HANDLE (3) UPWARD AND PUSH FORWARD UNTIL IT LATCHES

*REMOVE FIRING CIRCUIT TESTER (5) FROM BREECH

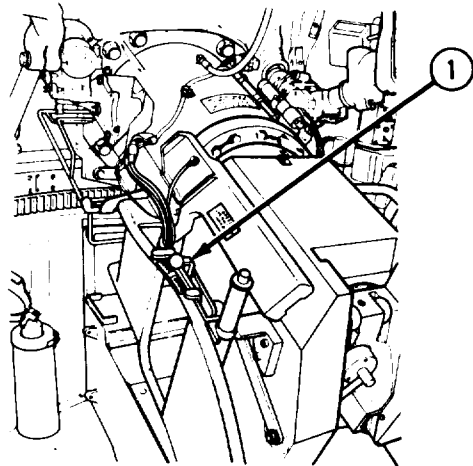

LOADER'S SAFETY SWITCH
LATE MODEL

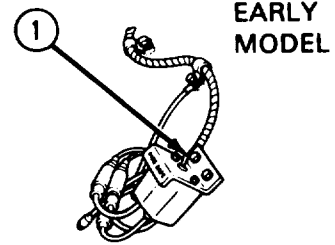

EARLY MODEL
LOADER'S SAFETY SWITCH

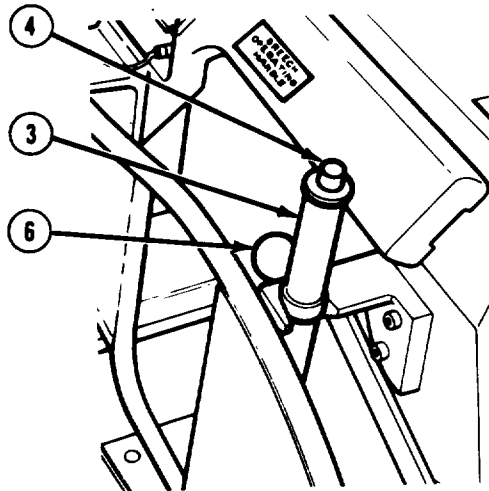

BREECHLOCK RELEASE LEVER AND
BREECH OPERATING HANDLE

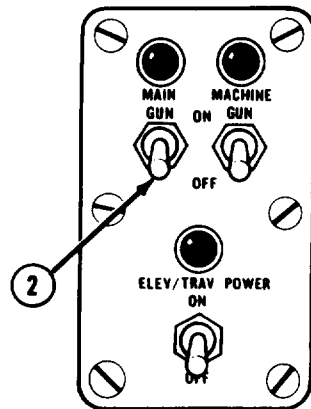

GUNNER'S CONTROL BOX

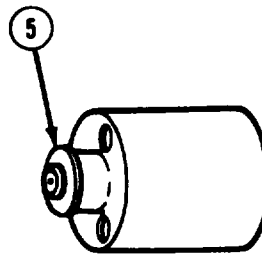

FIRING CIRCUIT TESTER

WARNING

02

BE SURE THAT BREECH OPERATING HANDLE IS LATCHED BEFORE CLOSING BREECH. IF NOT LATCHED, HANDLE WILL SPRING UP VIOLENTLY WHEN BREECH IS CLOSED.

03

*PULL BREECHBLOCK RELEASE LEVER (6) UPWARD TO CLOSE BREECH

22.01

3-3. MAIN GUN FIRING TROUBLESHOOTING (SHEET 22 OF 56)

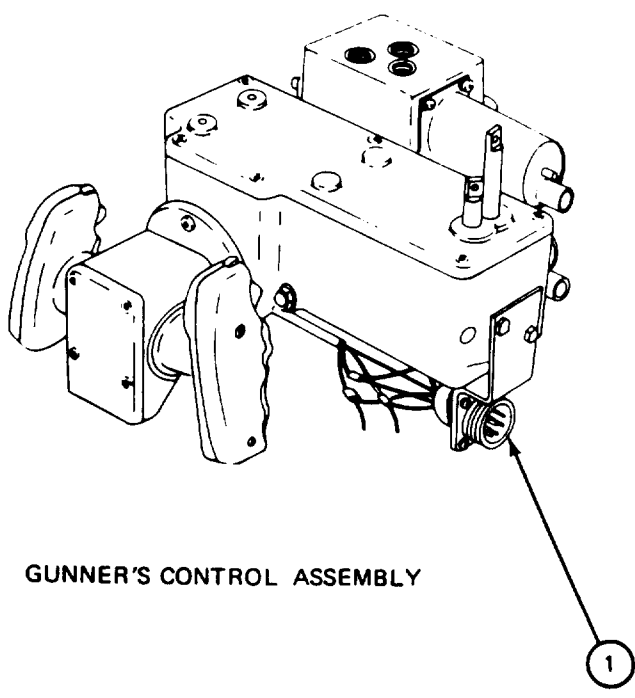
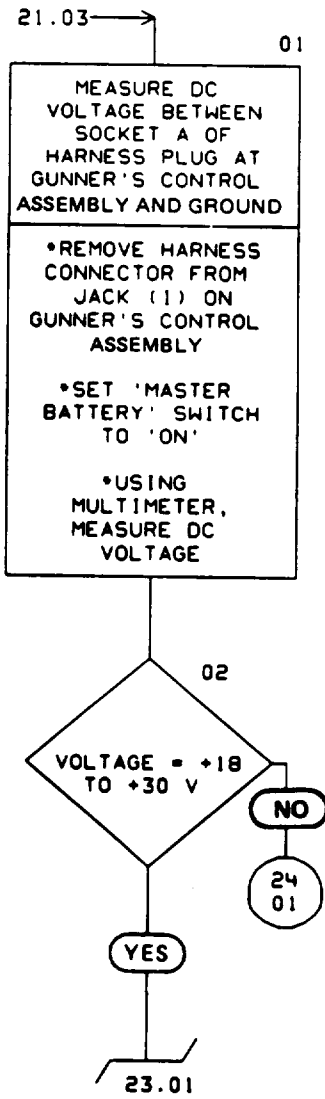

3-3. MAIN GUN FIRING TROUBLESHOOTING (SHEET 23 OF 56)

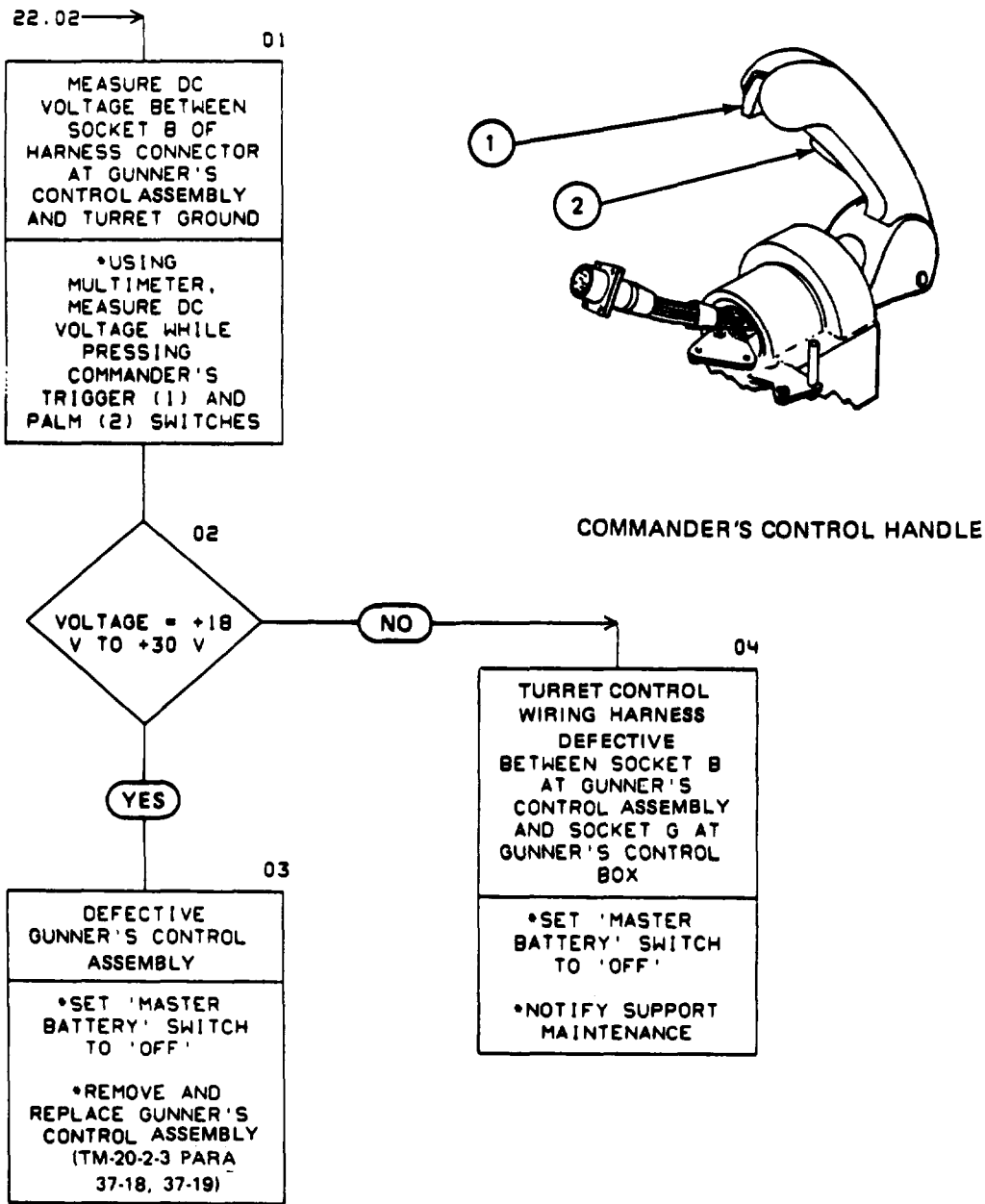

3-3. MAIN GUN FIRING TROUBLESHOOTING (SHEET 24 OF 56)

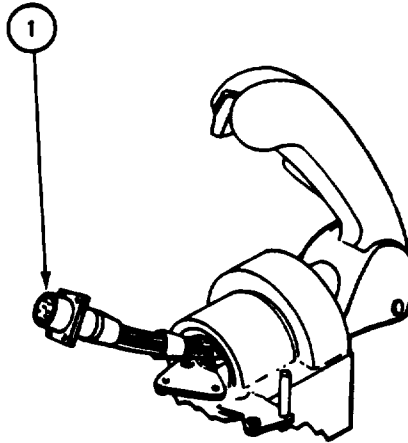
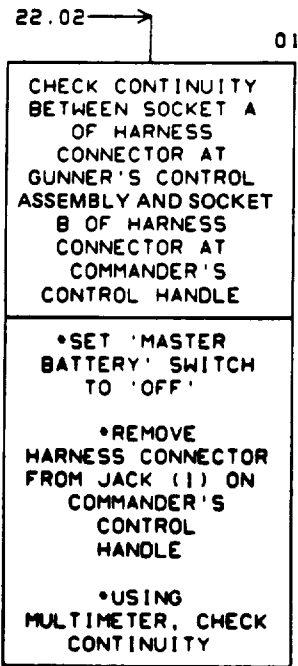

COMMANDER'S CONTROL HANDLE

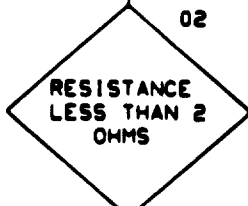

YES

NO

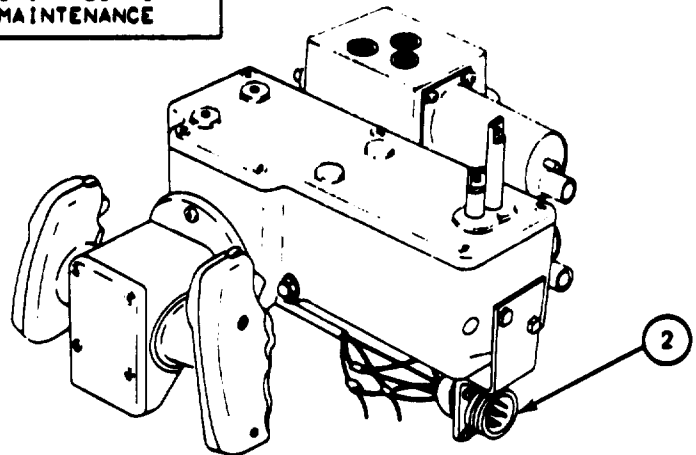
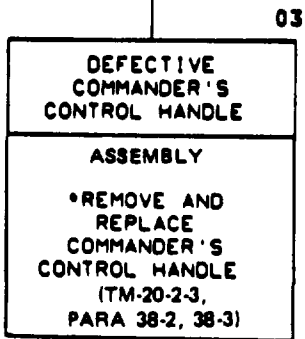
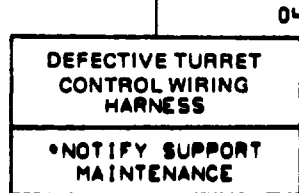

GUNNER'S CONTROL ASSEMBLY

3-3. MAIN GUN FIRING TROUBLESHOOTING (SHEET 25 OF 56)

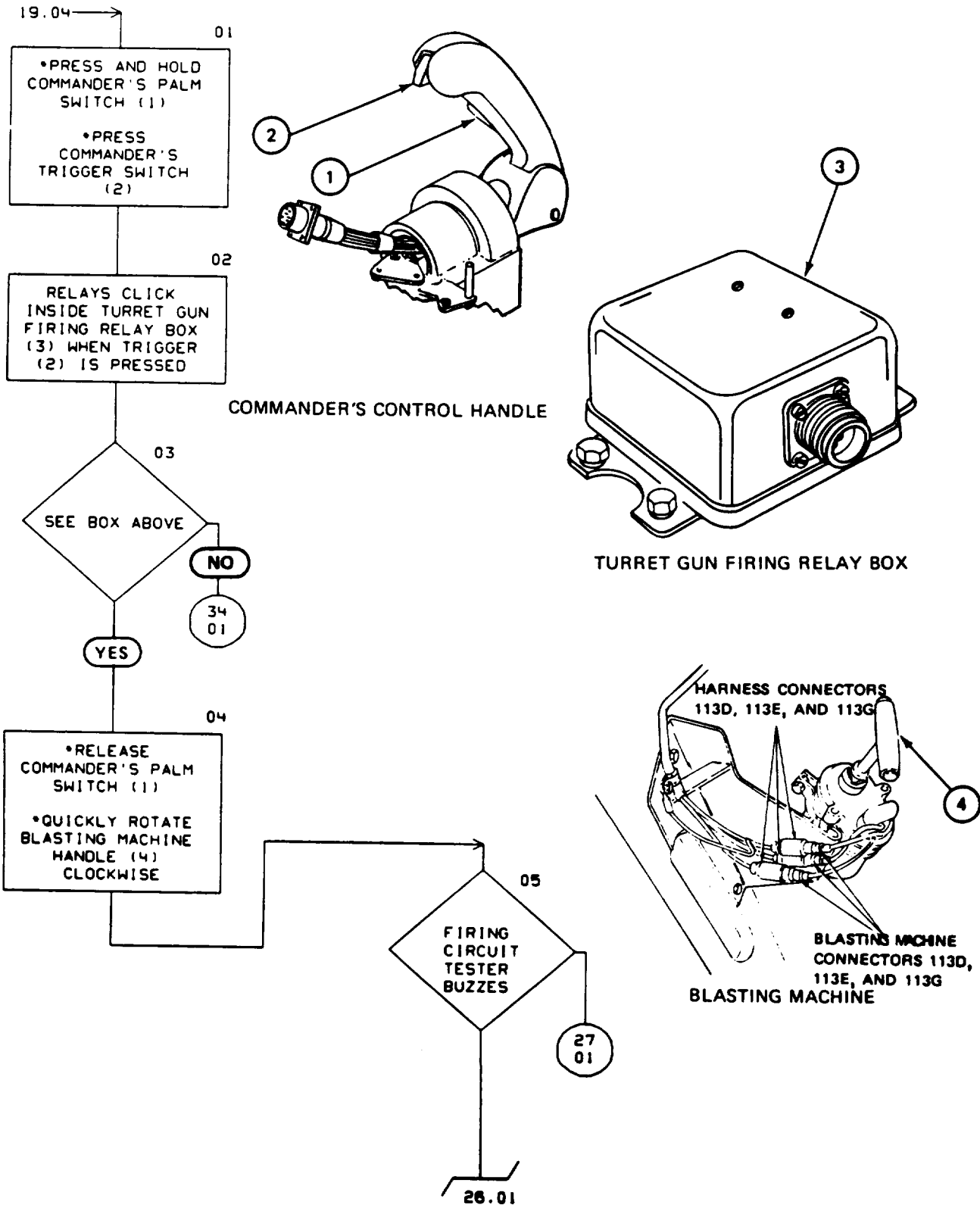

3-3. MAIN GUN FIRING TROUBLESHOOTING (SHEET 26 OF 56)

25.05 → 01

REMOVE FIRING CIRCUIT TESTER

- SET 'MASTER BATTERY' SWITCH TO 'OFF'
- GRASP BREECH OPERATING HANDLE (1) WITH RIGHT HAND. PRESS PLUNGER (2). PULL HANDLE (1) STRAIGHT OUT AND SWING DOWNWARD UNTIL THE BREECHBLOCK IS FULLY OPEN
- RELEASE PLUNGER (2). SWING HANDLE (1) UPWARD AND PUSH FORWARD UNTIL IT LATCHES
- REMOVE FIRING CIRCUIT TESTER (3) FROM BREECH

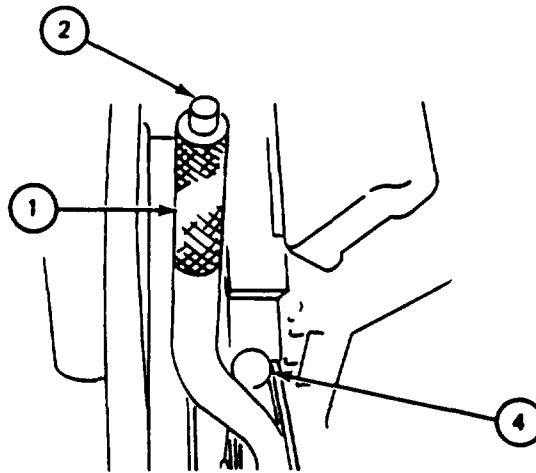

BREECHLOCK RELEASE LEVER AND BREECH OPERATING HANDLE

WARNING

BE SURE THAT BREECH OPERATING HANDLE IS LATCHED BEFORE CLOSING BREECH. IF NOT LATCHED, HANDLE WILL SPRING UP VIOLENTLY WHEN BREECH IS CLOSED

02

•PULL BREECHBLOCK RELEASE LEVER (4) UPWARD TO CLOSE BREECH

03

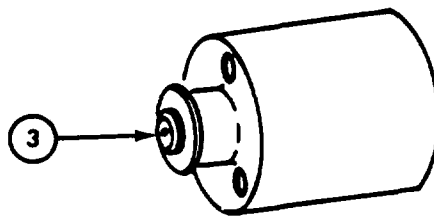

FIRING CIRCUIT TESTER

31
02

3-3. MAIN GUN FIRING TROUBLESHOOTING (SHEET 27 OF 56)

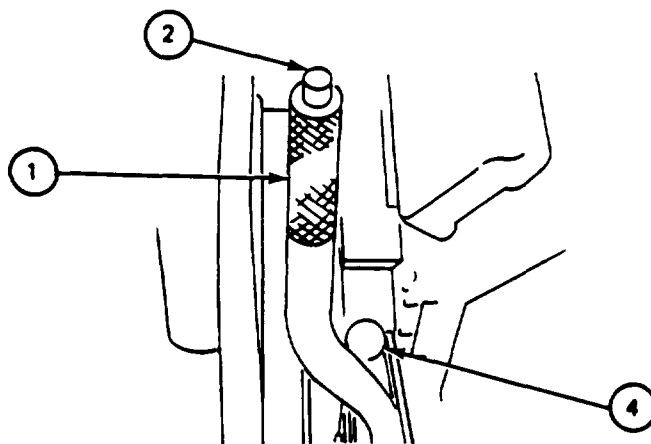
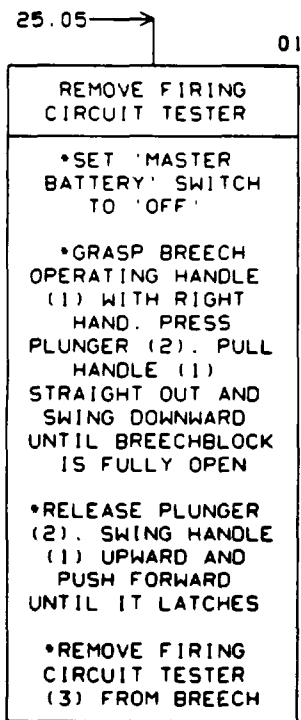

BREECHLOCK RELEASE LEVER AND BREECH OPERATING HANDLE

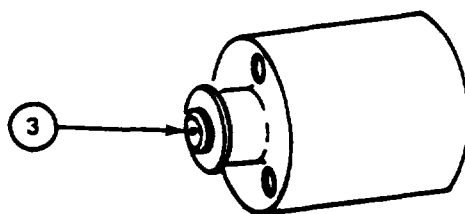
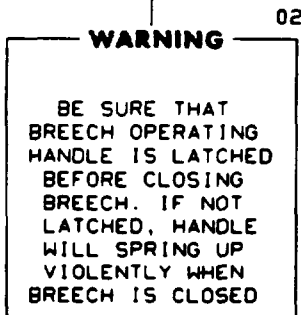

FIRING CIRCUIT TESTER

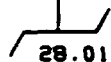

3-3. MAIN GUN FIRING TROUBLESHOOTING (SHEET 28 OF 56)

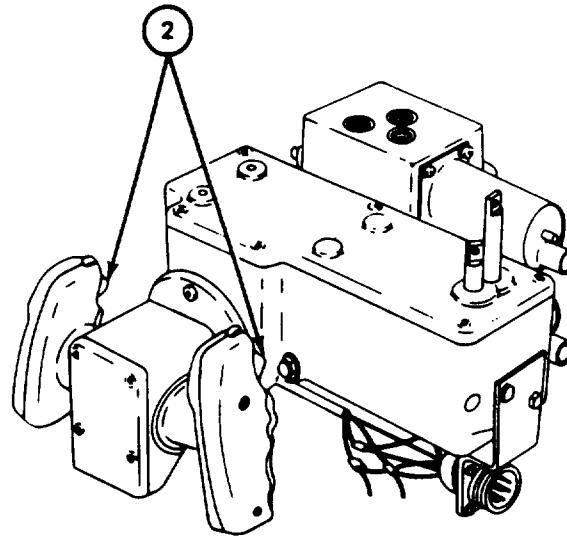
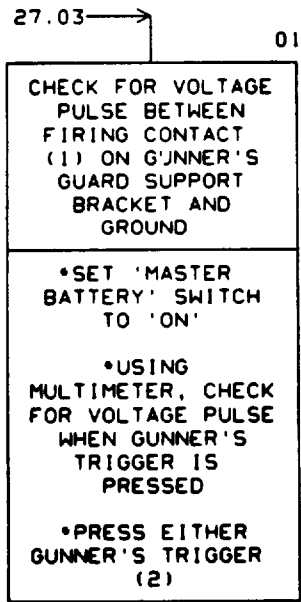

GUNNER'S CONTROL ASSEMBLY

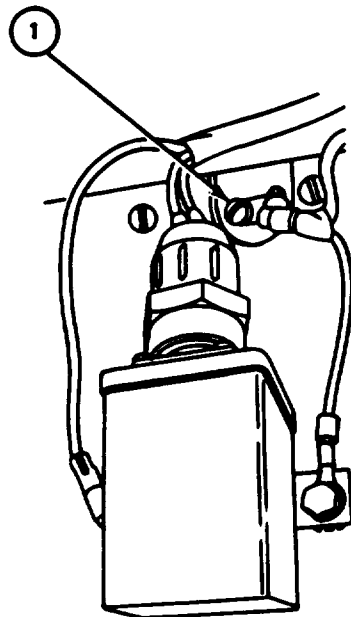
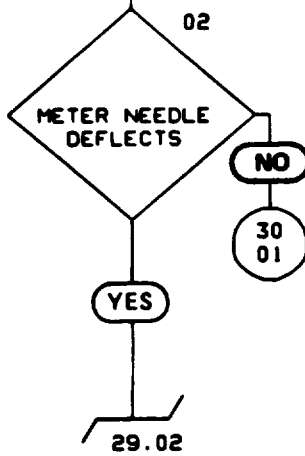

SAFETY RELAY SWITCH AND FIRING CONTACT

3-3. MAIN GUN FIRING TROUBLESHOOTING (SHEET 29 OF 56)

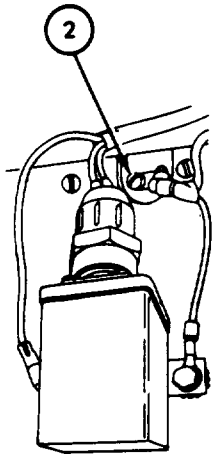

SAFETY RELAY SWITCH AND FIRING CONTACT

28.02 → 02

CHECK CONTINUITY BETWEEN BREECH RING CONTACT (1) AND FIRING CONTACT (2)

*SET 'MASTER BATTERY' SWITCH TO 'OFF'

*GRASP BREECH OPERATING HANDLE (3) WITH RIGHT HAND. PRESS PLUNGER (4). PULL HANDLE (3) STRAIGHT OUT AND SWING DOWNWARD UNTIL BREECHBLOCK IS FULLY OPEN

*RELEASE PLUNGER (4). SWING HANDLE (3) UPWARD AND PUSH FORWARD UNTIL IT LATCHES

*USING MULTIMETER, CHECK CONTINUITY

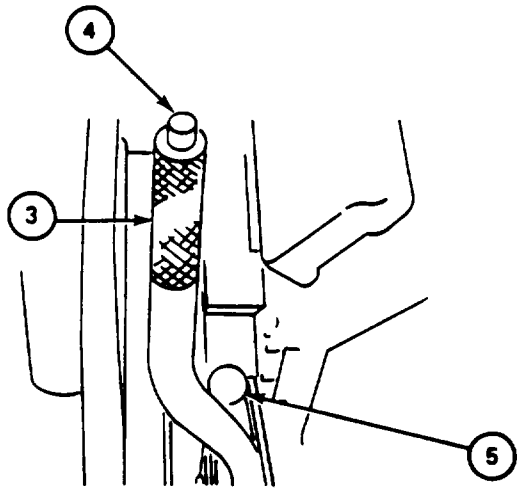

BREECHLOCK RELEASE LEVER AND BREECH OPERATING HANDLE

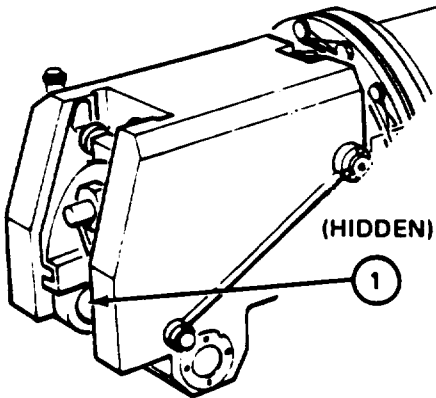

MAIN GUN BREECH

03

RESISTANCE LESS THAN 2 OHMS

YES

NO

01

DEFECTIVE BREECH RING FIRING CIRCUIT

*INSPECT AND REPAIR BREECH RING FIRING CIRCUIT AS NECESSARY (TM-20-2-3, PARA 32-2)

29
05

04

DEFECTIVE BREECHBLOCK FIRING CIRCUIT

*INSPECT AND REPAIR BREECHBLOCK FIRING CIRCUIT AS NECESSARY (TM-20-2-3, PARA 32-2)

29.01 → 05

WARNING

BE SURE THAT BREECH OPERATING HANDLE IS LATCHED BEFORE CLOSING BREECH. IF NOT LATCHED, HANDLE WILL SPRING UP VIOLENTLY WHEN BREECH IS CLOSED

06

CLOSE BREECH

*PULL BREECHBLOCK RELEASE LEVER (5) UPWARD

3-3. MAIN GUN FIRING TROUBLESHOOTING (SHEET 30 OF 56)

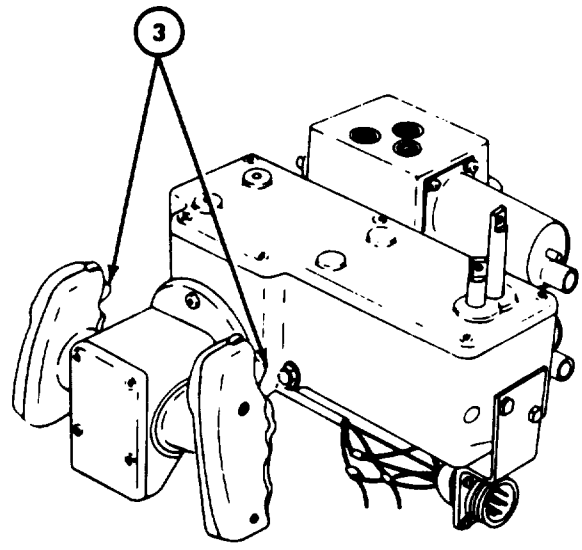
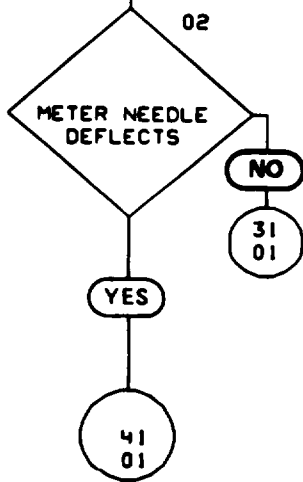
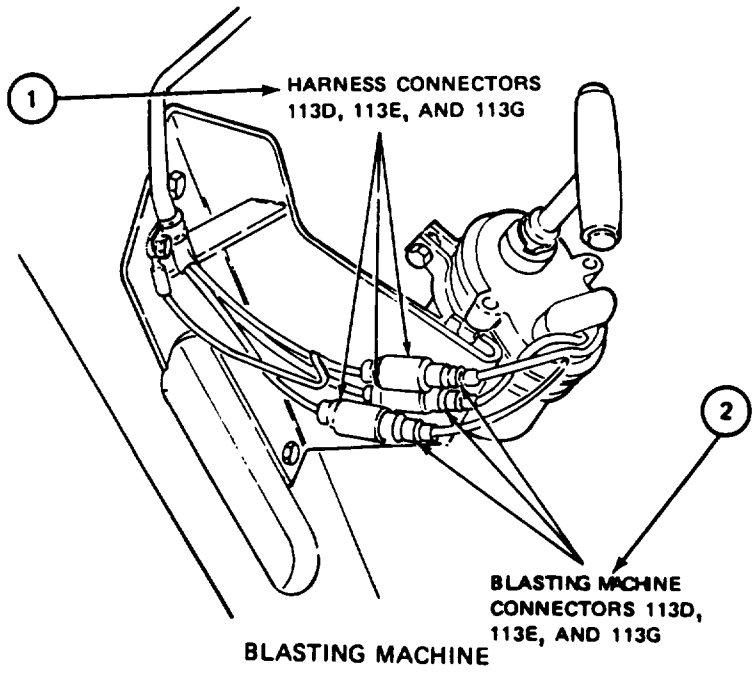
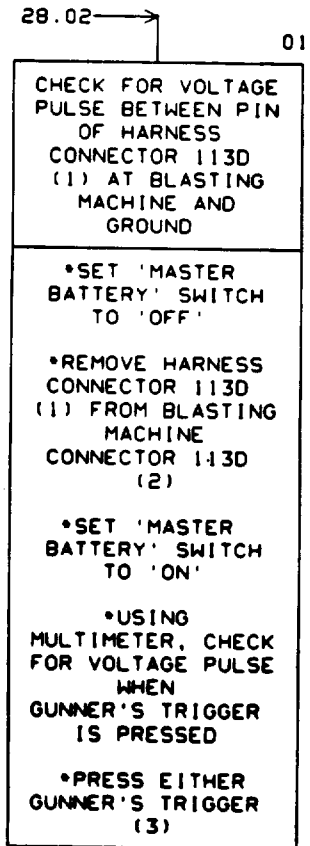

GUNNER'S CONTROL ASSEMBLY

3-3. MAIN GUN FIRING TROUBLESHOOTING (SHEET 31 OF 56)

30.02 →

01

•SET 'MASTER BATTERY' SWITCH TO 'OFF'

•CONNECT HARNESS CONNECTOR 113D (1) TO BLASTING MACHINE CONNECTOR 113D (2)

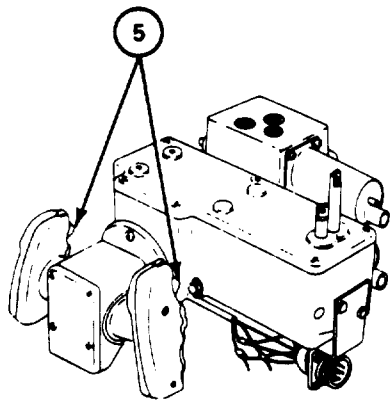

GUNNER'S CONTROL ASSEMBLY

26.03 →

02

CHECK DC VOLTAGE PULSE BETWEEN PIN B OF GUN QUICK DISCONNECT CONNECTOR (3) AND GROUND

•SEPARATE THE TWO CONNECTORS OF THE GUN QUICK DISCONNECT (3) AND (4)

•SET 'MASTER BATTERY' SWITCH TO 'ON'

•USING MULTIMETER, CHECK FOR DC VOLTAGE PULSE WHEN GUNNER'S TRIGGER IS PRESSED

•PRESS EITHER GUNNER'S TRIGGER (5)

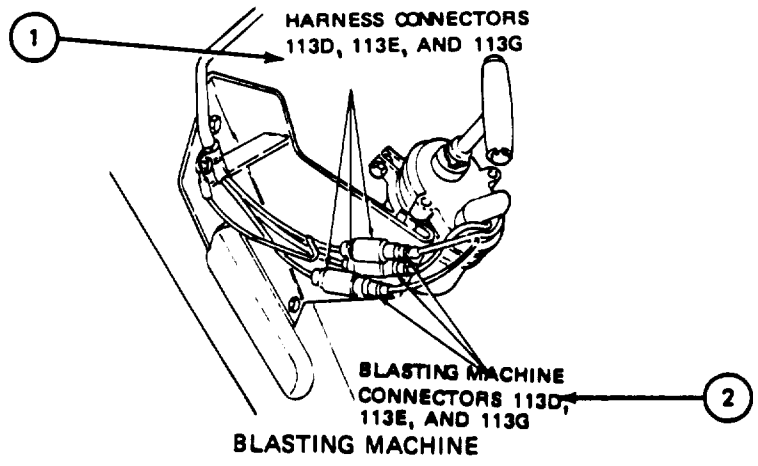

BLASTING MACHINE

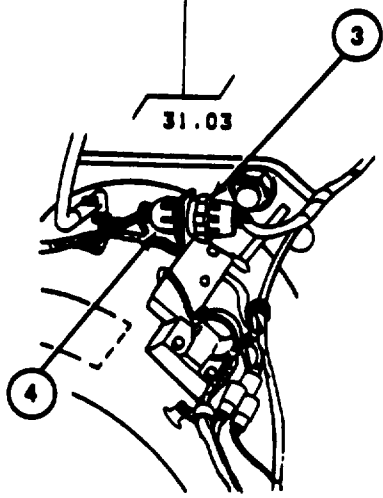

GUN QUICK DISCONNECT

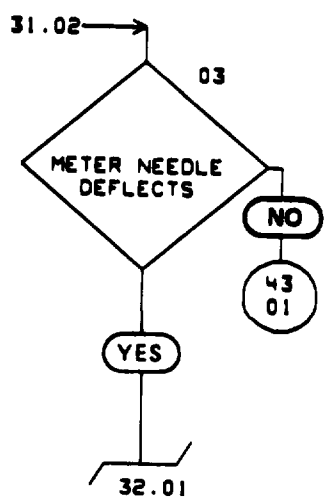

3-3. MAIN GUN FIRING TROUBLESHOOTING (SHEET 32 OF 56)

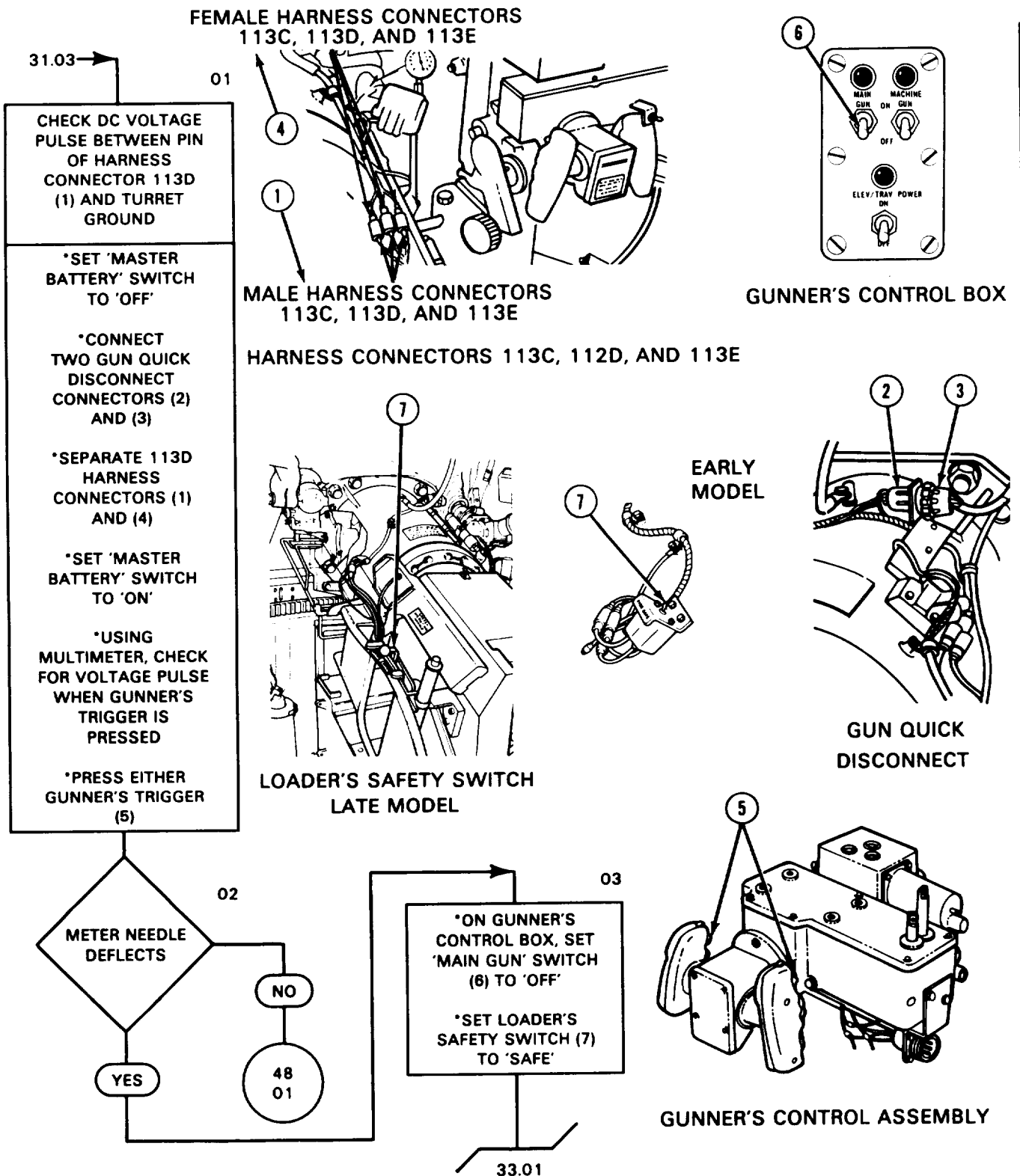

3-3. MAIN GUN FIRING TROUBLESHOOTING (SHEET 33 OF 56)

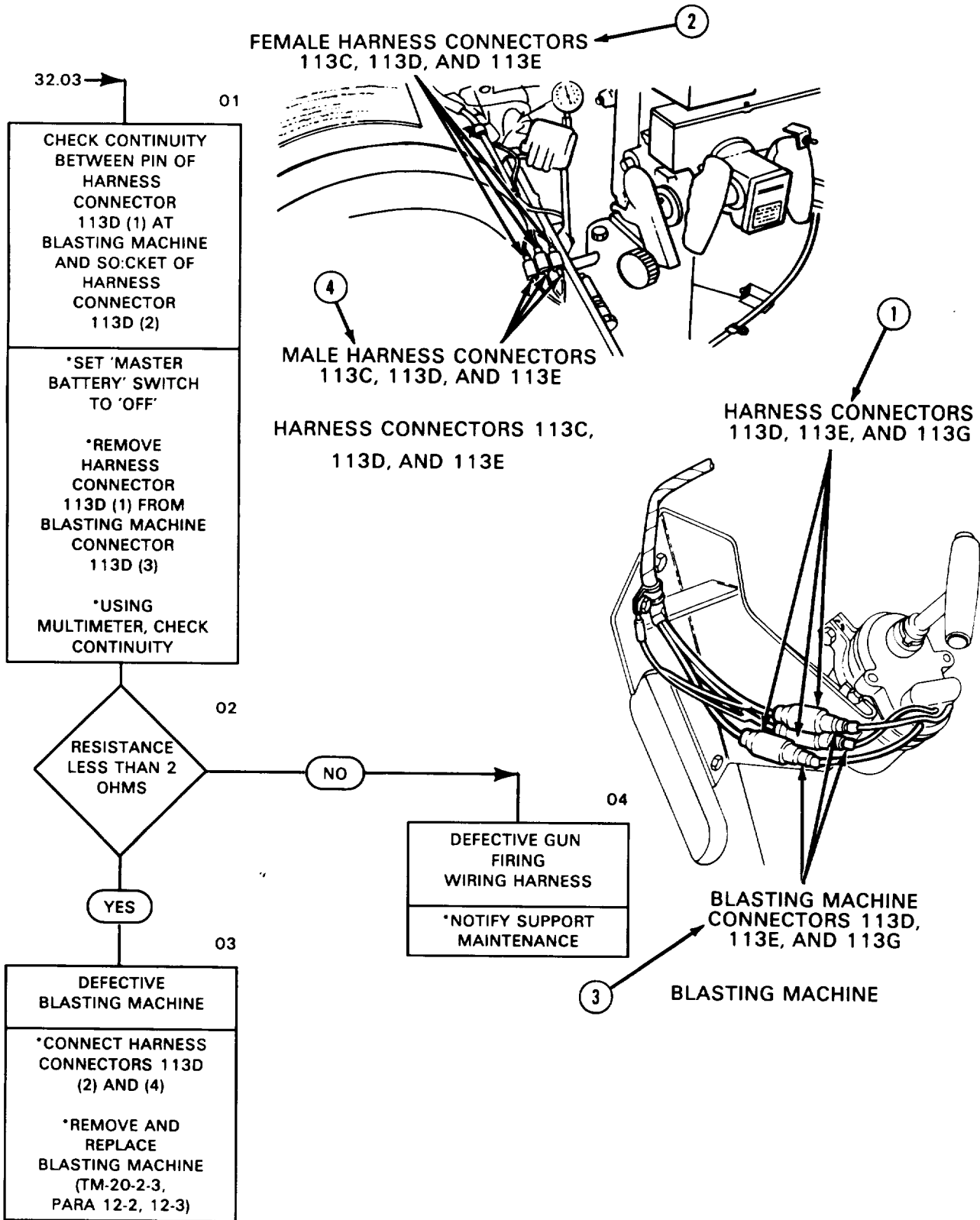

3-3. MAIN GUN FIRING TROUBLESHOOTING (SHEET 34 OF 56)

25.03 →

01

RELEASE
COMMANDER'S PALM
SWITCH (1)

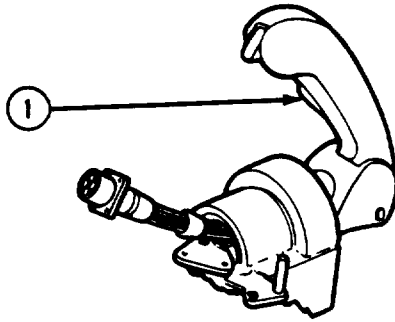

COMMANDER'S CONTROL ASSEMBLY

02

REMOVE FIRING
CIRCUIT TESTER

*SET LOADER'S
SAFETY SWITCH (1)
TO 'SAFE'

*GRASP BREECH
OPERATING HANDLE
(3) WITH RIGHT
HAND. PRESS
PLUNGER (4). PULL
HANDLE (3)
STRAIGHT OUT AND
SWING DOWNWARD
UNTIL THE
BREECHBLOCK IS
FULLY OPEN

*RELEASE PLUNGER
(4). SWING HANDLE
(3) UPWARD AND
PUSH FORWARD
UNTIL IT LATCHES

*REMOVE FIRING
CIRCUIT TESTER
(5) FROM BREECH

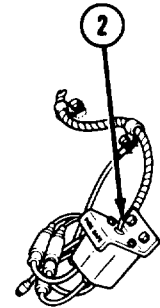

EARLY
MODEL

LOADER'S SAFETY SWITCH

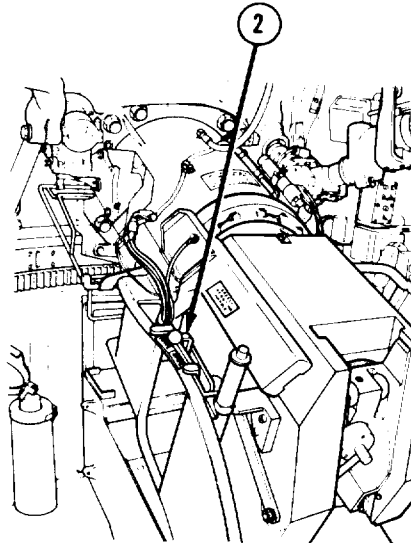

LOADER'S SAFETY SWITCH
LATE MODEL

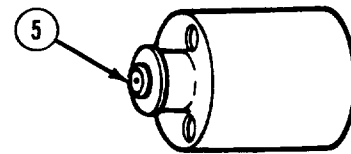

FIRING CIRCUIT TESTER

03

WARNING

BE SURE THAT
BREECH OPERATING
HANDLE IS LATCHED
BEFORE CLOSING
BREECH. IF NOT
LATCHED, HANDLE
WILL SPRING UP
VIOLENTLY WHEN
BREECH IS CLOSED.

04

*PULL
BREECHBLOCK
RELEASE LEVER (6)
UPWARD TO CLOSE
BREECH

35.01

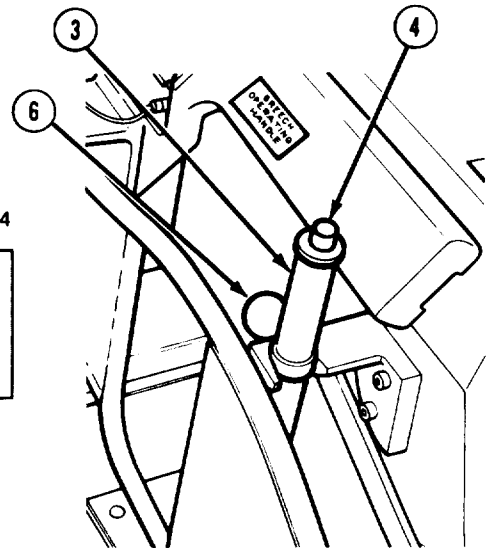

BREECHLOCK RELEASE LEVER AND
BREECH OPERATING HANDLE

3-3. MAIN GUN FIRING TROUBLESHOOTING (SHEET 35 OF 56)

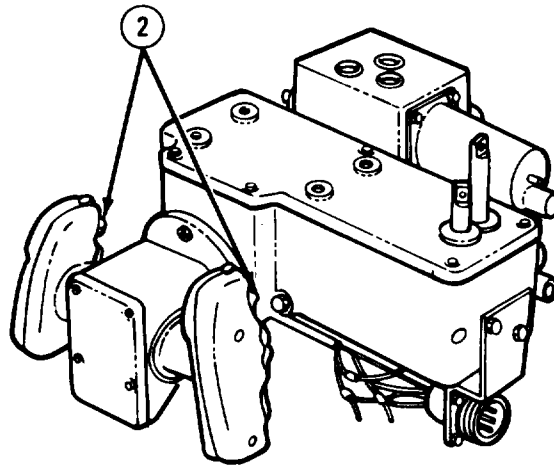
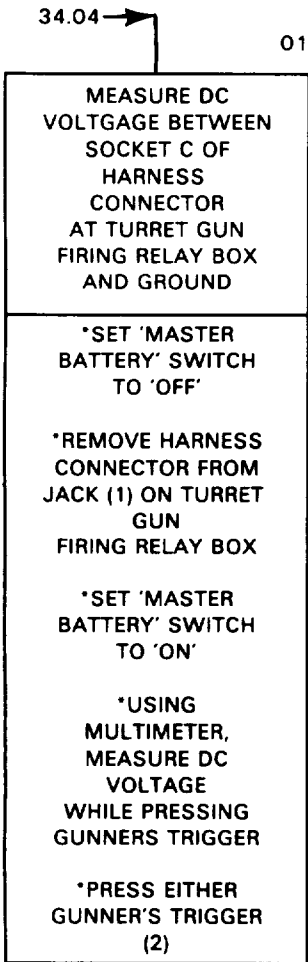

GUNNER'S CONTROL ASSEMBLY

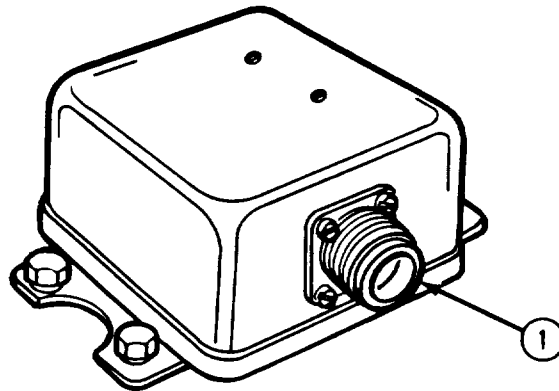
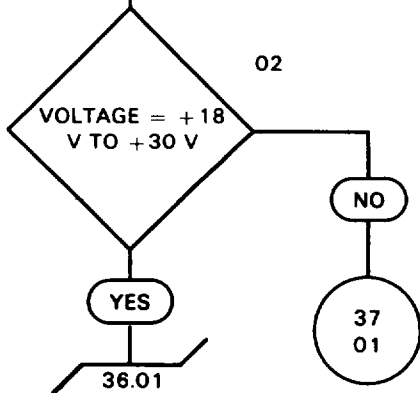

TURRET GUN FIRING RELAY BOX

3-3. MAIN GUN FIRING TROUBLESHOOTING (SHEET 36 OF 56)

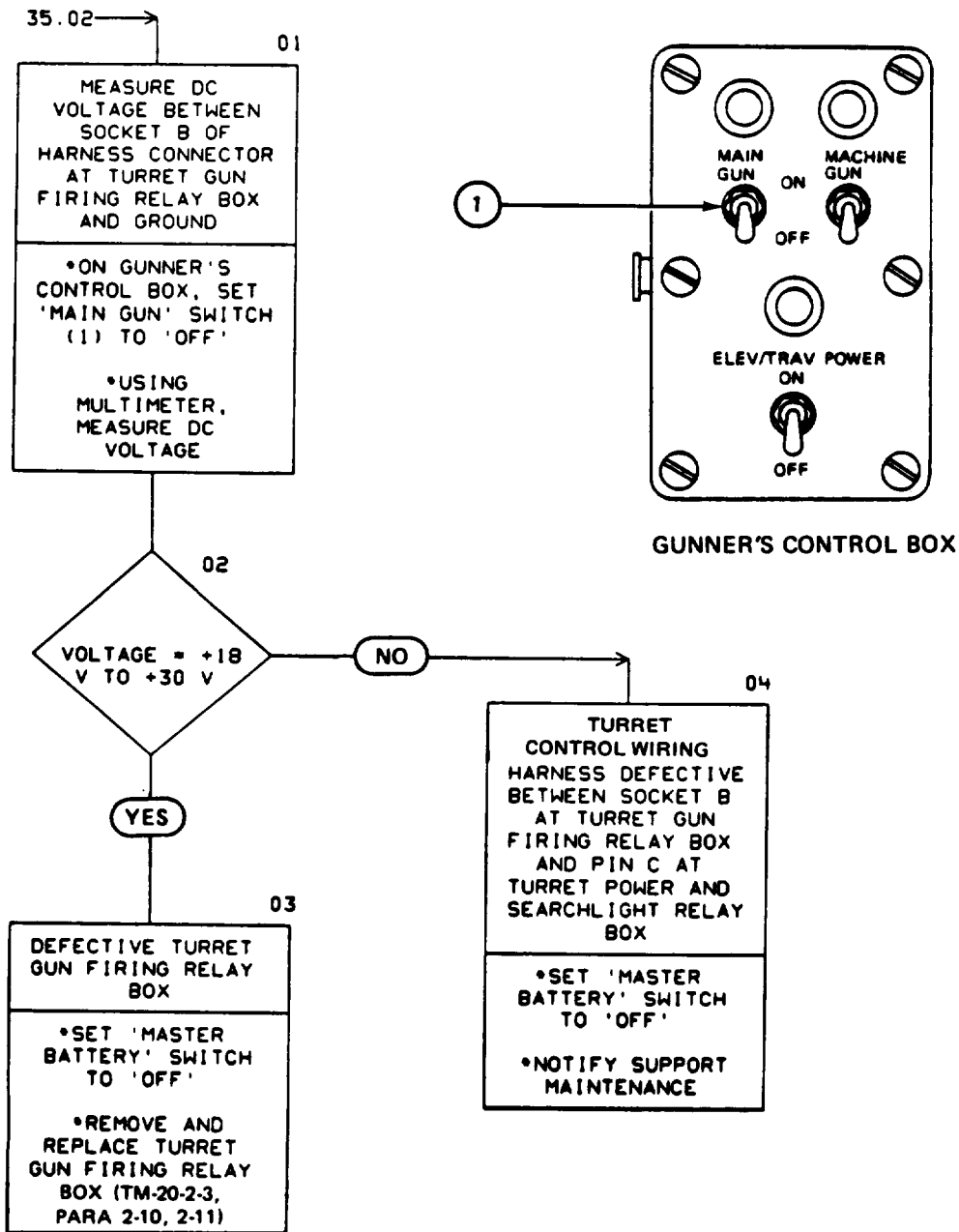

3.3. MAIN GUN FIRING TROUBLESHOOTING (SHEET 37 OF 56)

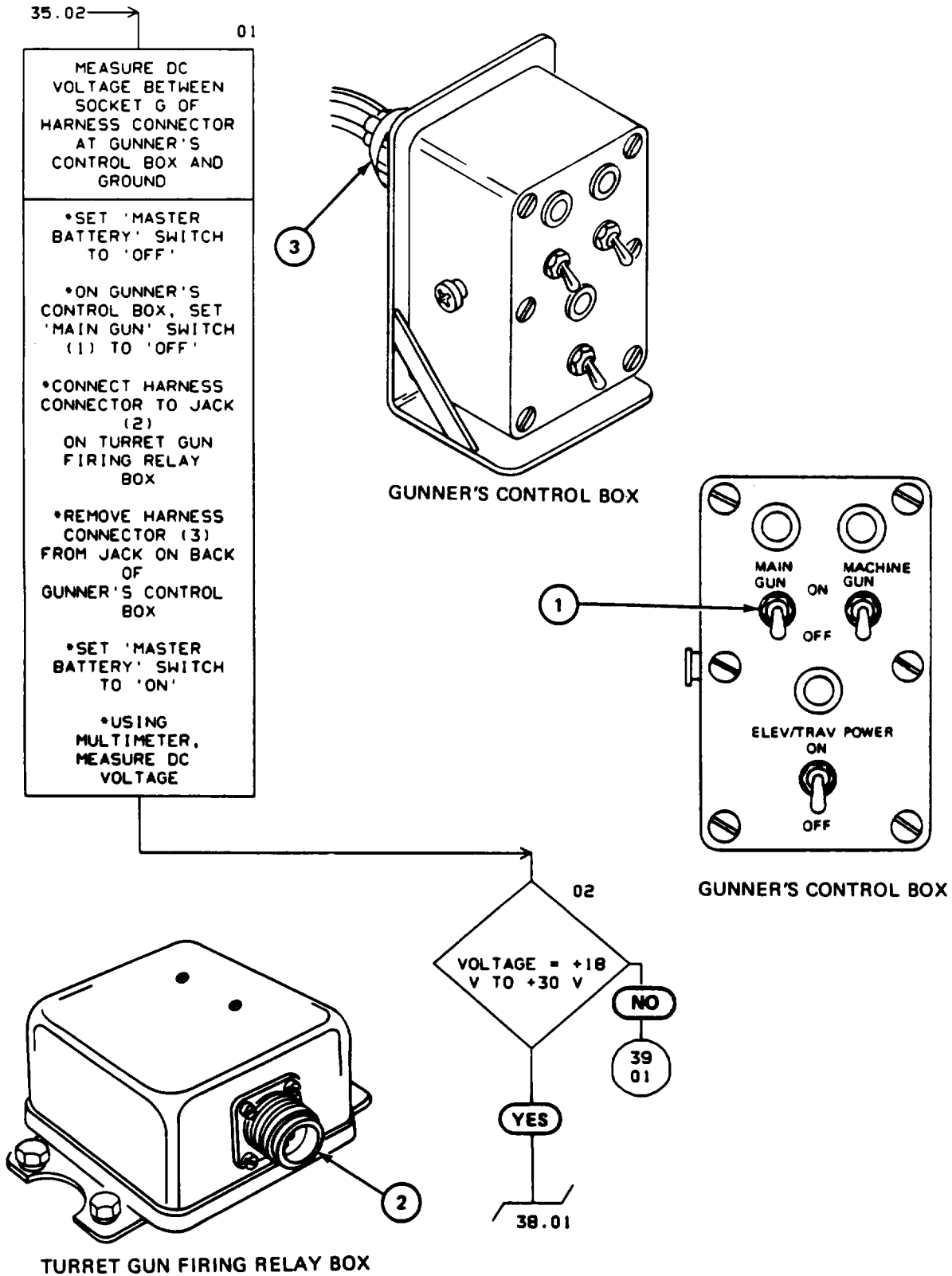

3-3. MAIN GUN FIRING TROUBLESHOOTING (SHEET 38 OF 56)

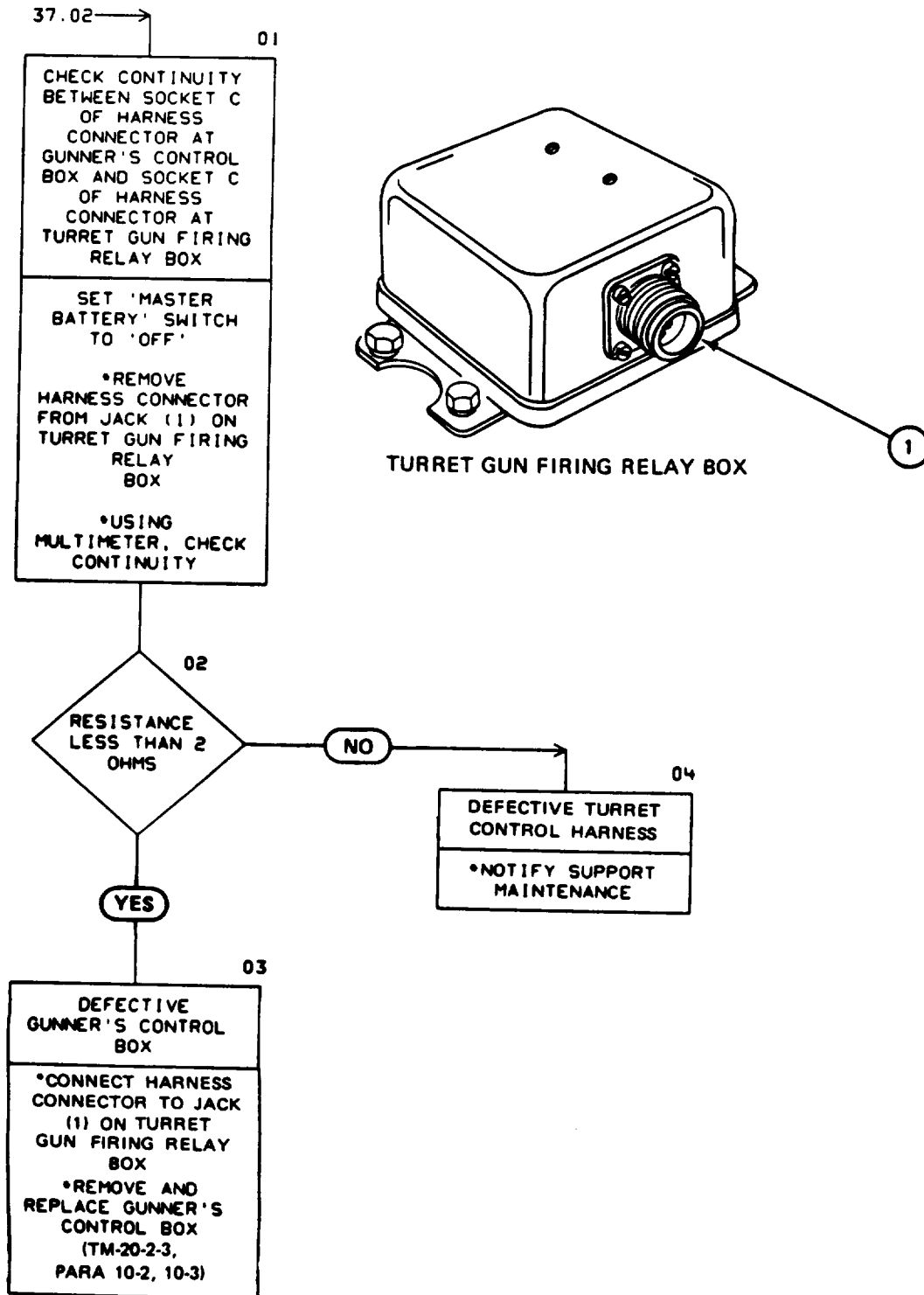

3.3. MAIN GUN FIRING TROUBLESHOOTING (SHEET 39 OF 56)

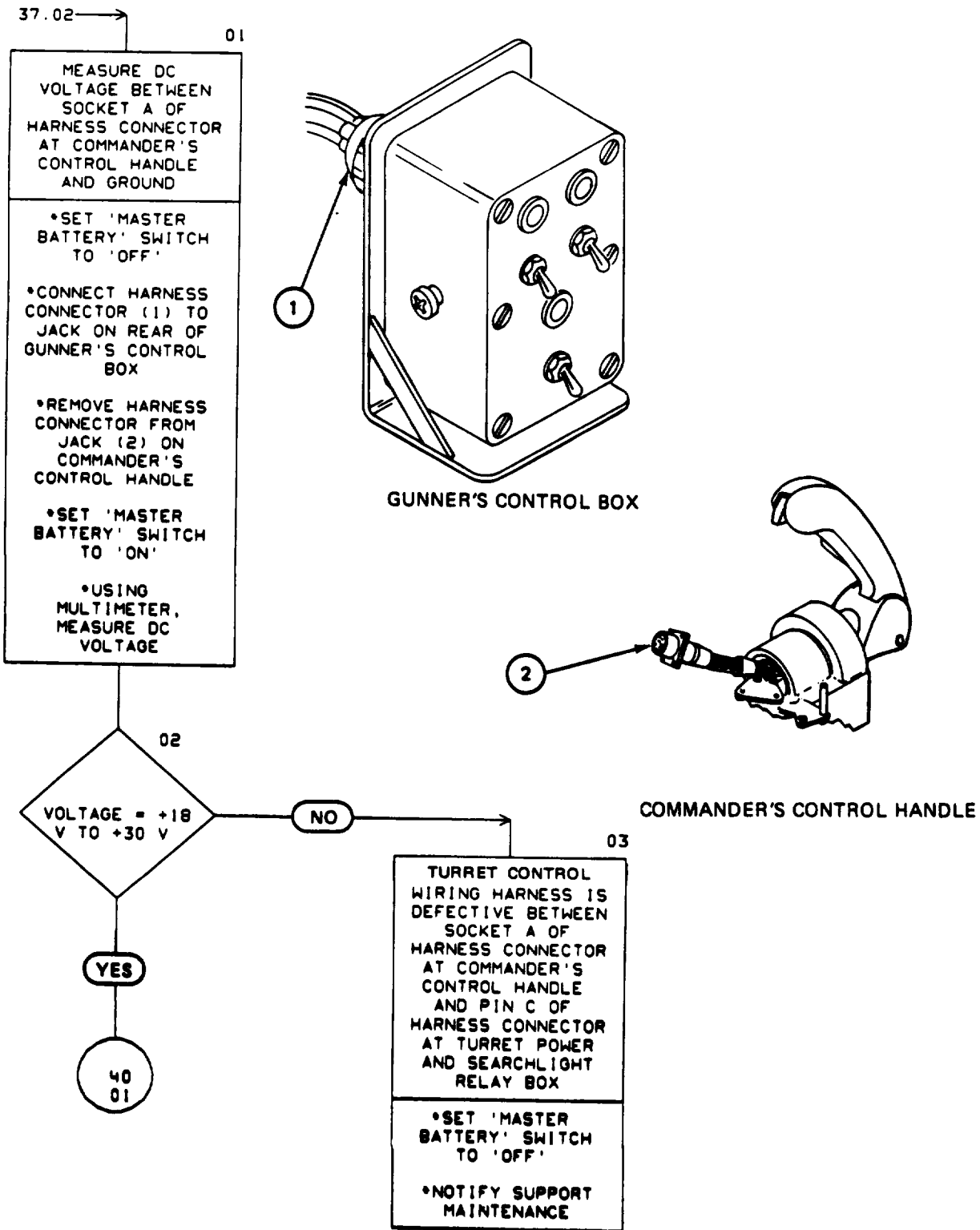

3-3. MAIN GUN FIRING TROUBLESHOOTING (SHEET 40 OF 56)

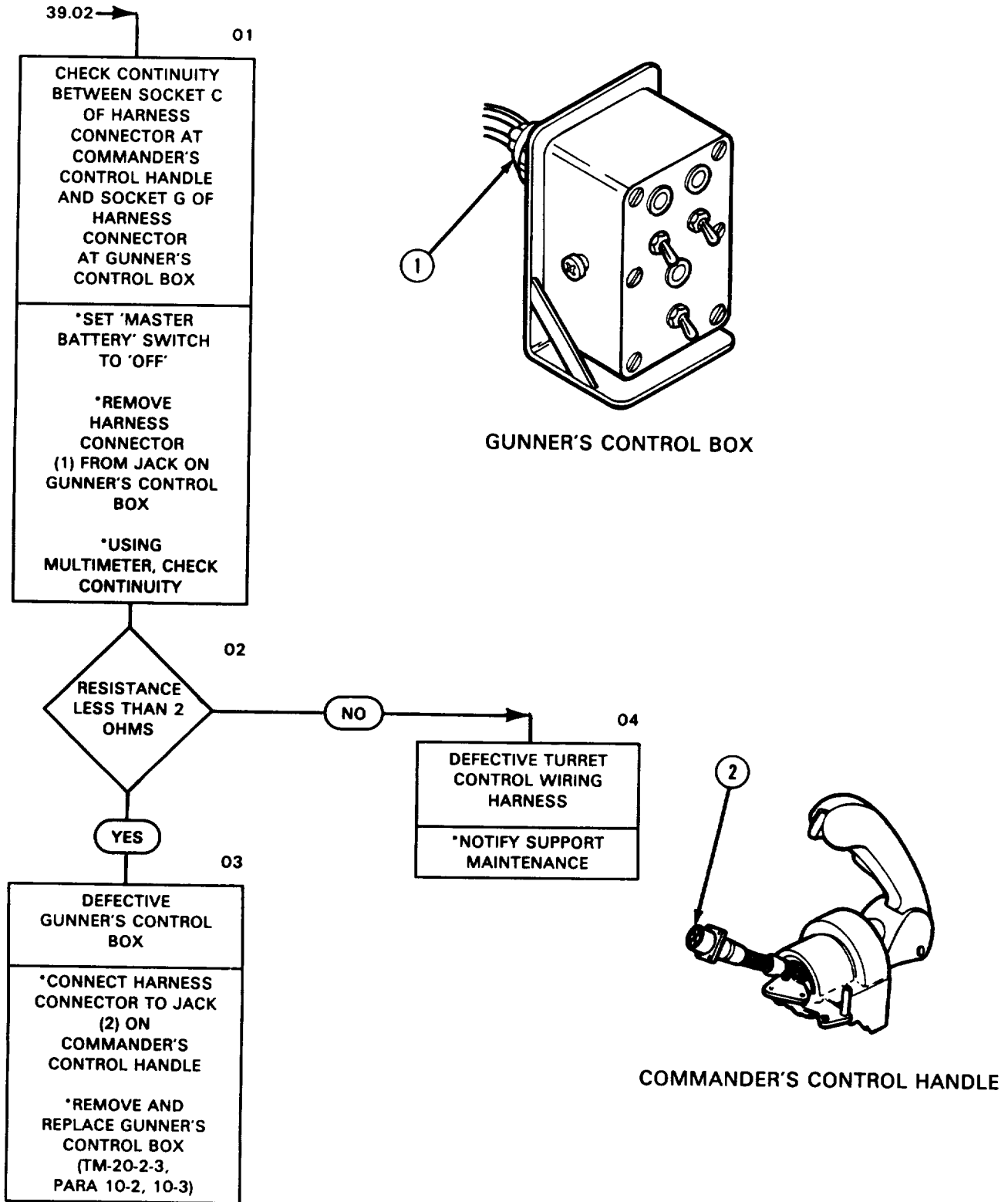

3-3. MAIN GUN FIRING TROUBLESHOOTING (SHEET 41 OF 56)

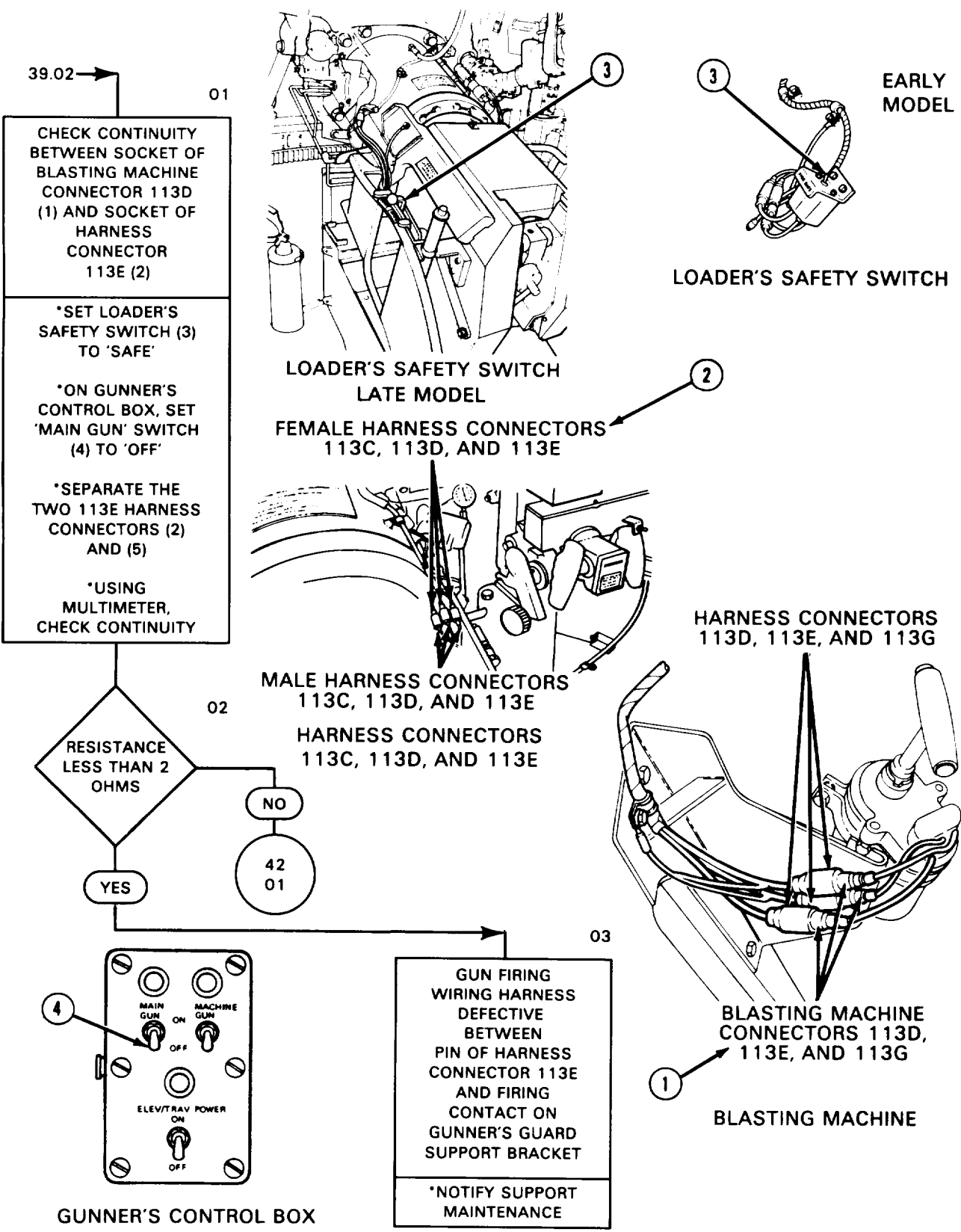

3-3. MAIN GUN FIRING TROUBLESHOOTING (SHEET 42 OF 56)

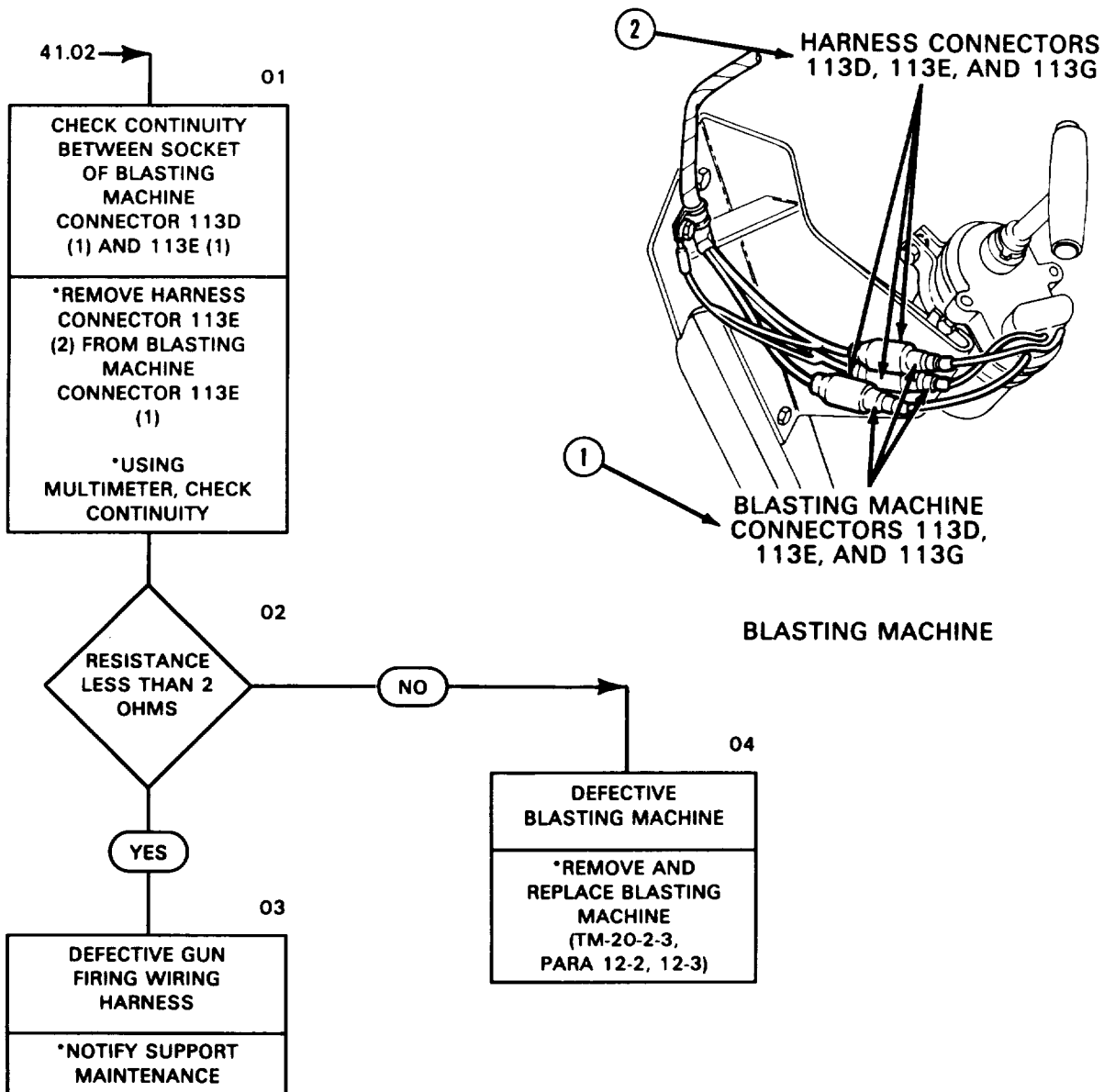

3-3. MAIN GUN FIRING TROUBLESHOOTING (SHEET 43 OF 56)

31.03 →

01

CHECK CONTINUITY BETWEEN PIN B OF GUN QUICK DISCONNECT CONNECTOR AND SOCKET F OF HARNESS CONNECTOR AT TURRET GUN FIRING RELAY BOX

*SET LOADER'S SAFETY SWITCH (1) TO 'SAFE'

*ON GUNNER'S CONTROL BOX, SET 'MAIN GUN' SWITCH (2) TO 'ON'

*SET 'MASTER BATTERY' SWITCH TO 'OFF'

*REMOVE HARNESS CONNECTOR FROM JACK (3) ON TURRET GUN FIRING RELAY BOX

*USING MULTIMETER, CHECK CONTINUITY

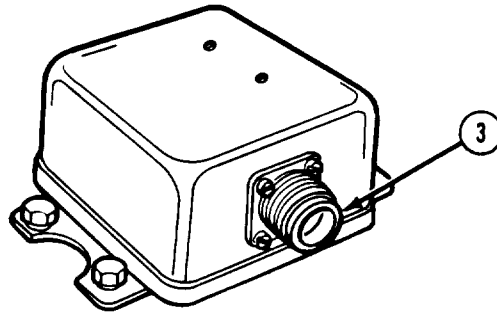

TURRET GUN FIRING RELAY BOX

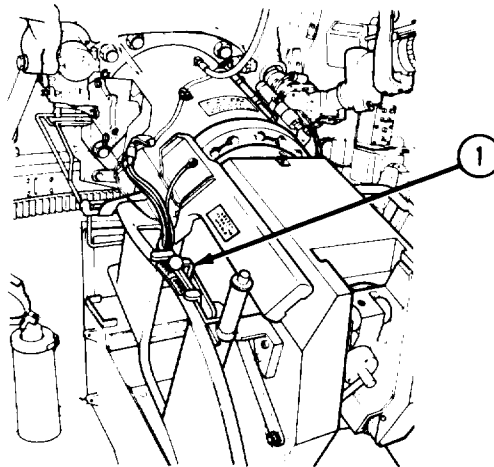

LOADER'S SAFETY SWITCH LATE MODEL

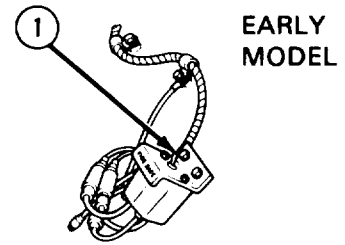

LOADER'S SAFETY SWITCH EARLY MODEL

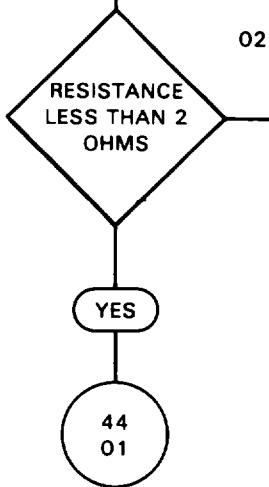

03

DEFECTIVE TURRET CONTROL WIRING HARNESS

*NOTIFY SUPPORT MAINTENANCE

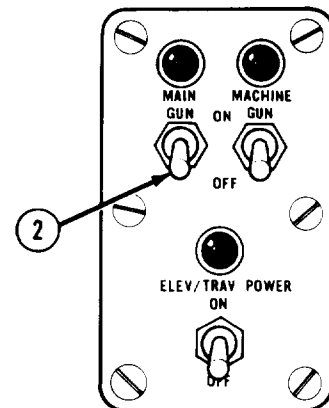

GUNNER'S CONTROL BOX

3-3. MAIN GUN FIRING TROUBLESHOOTING (SHEET 44 OF 56)

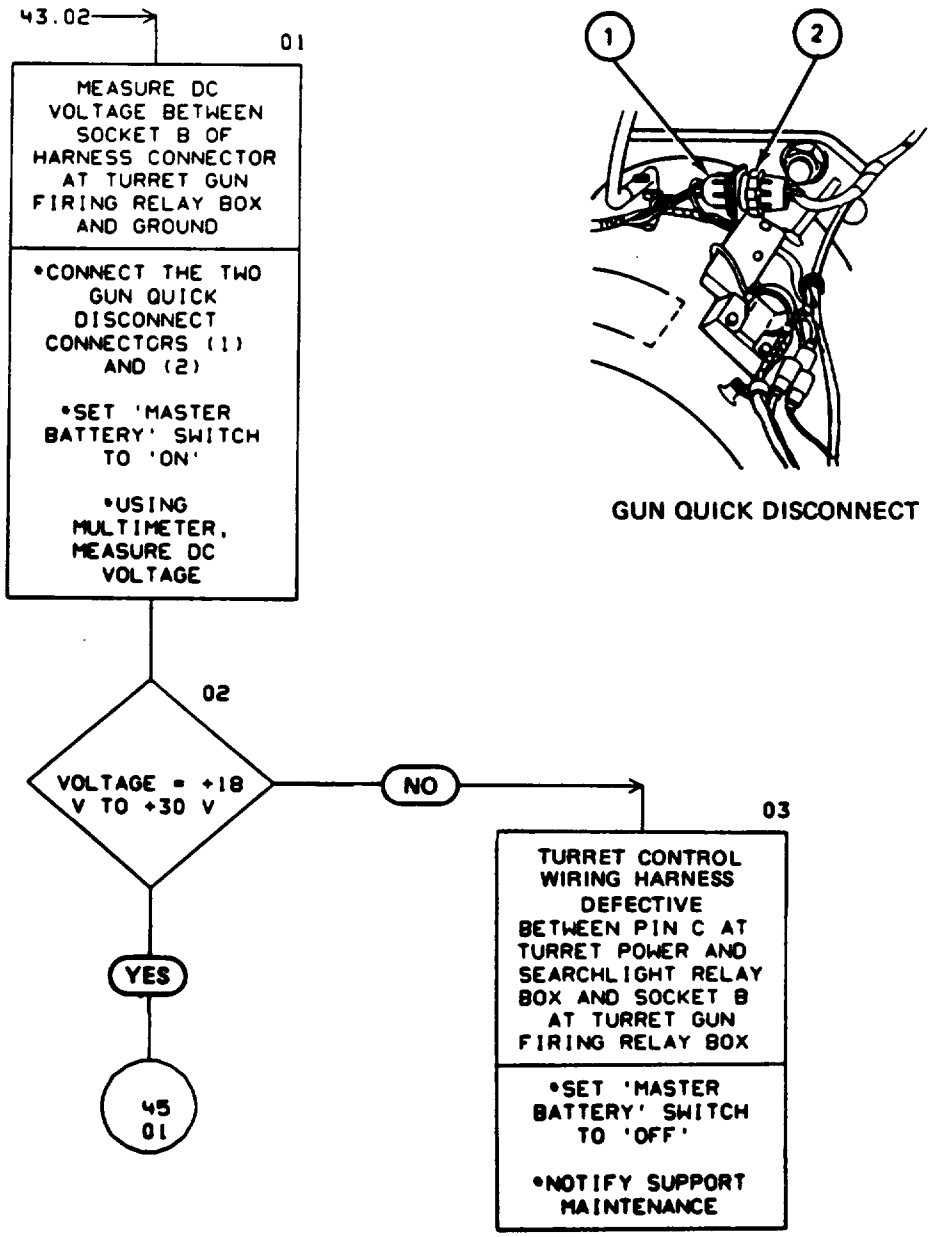

3-3. MAIN GUN FIRING TROUBLESHOOTING (SHEET 45 OF 56)

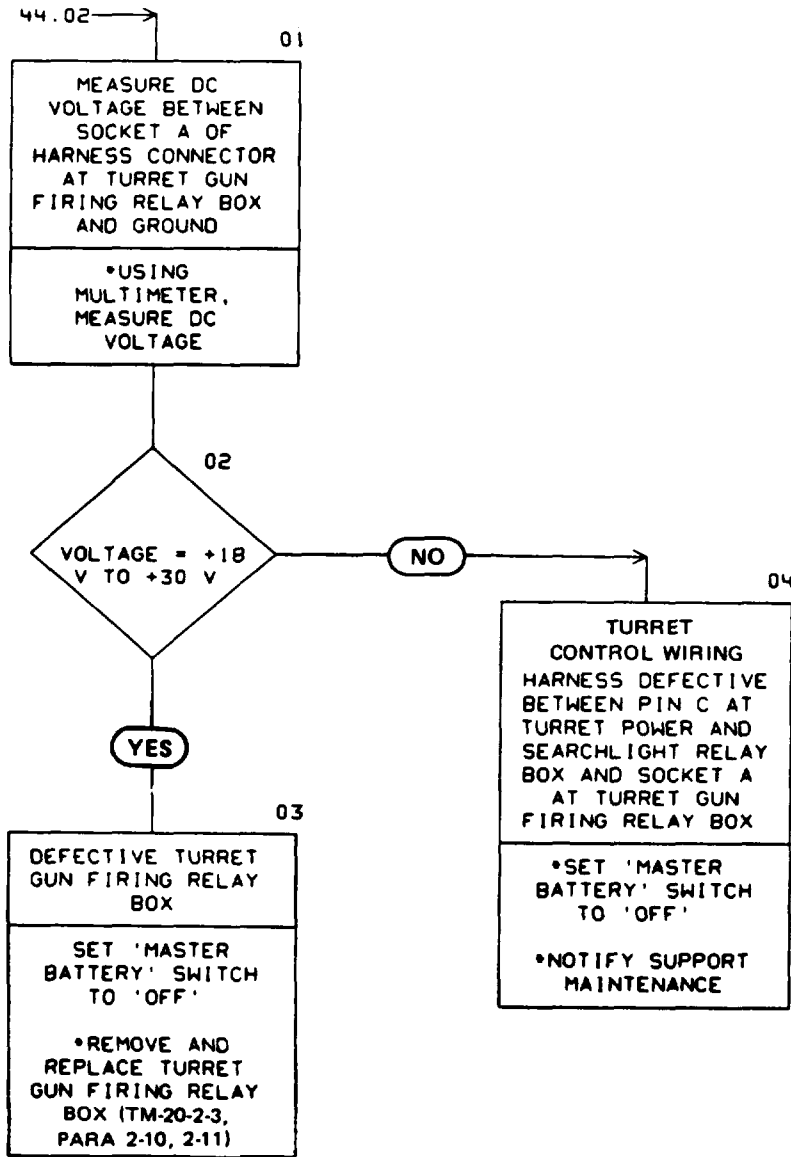

3-3. MAIN GUN FIRING TROUBLESHOOTING (SHEET 46 OF 56)

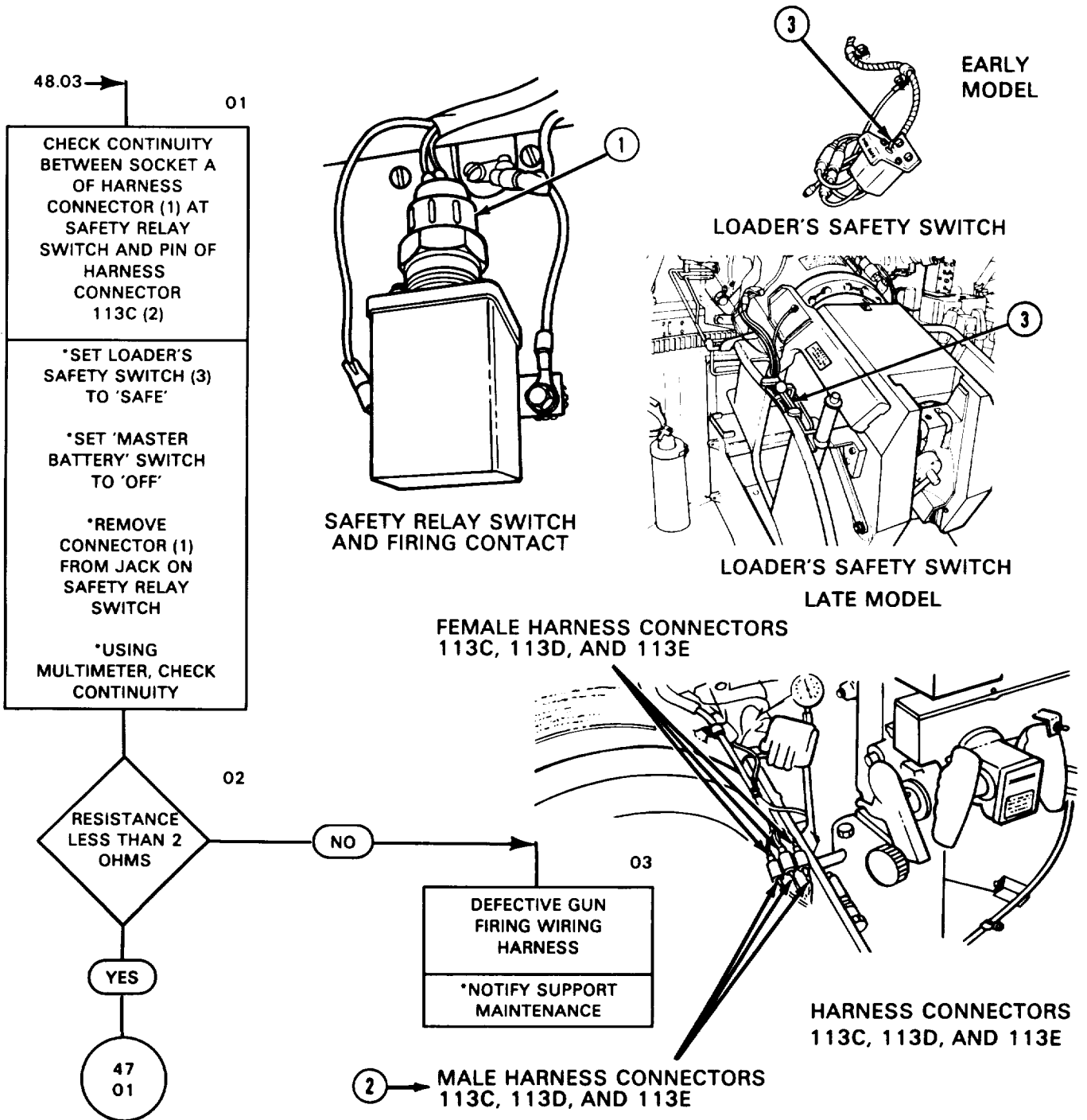

3-3. MAIN GUN FIRING TROUBLESHOOTING (SHEET 47 OF 56)

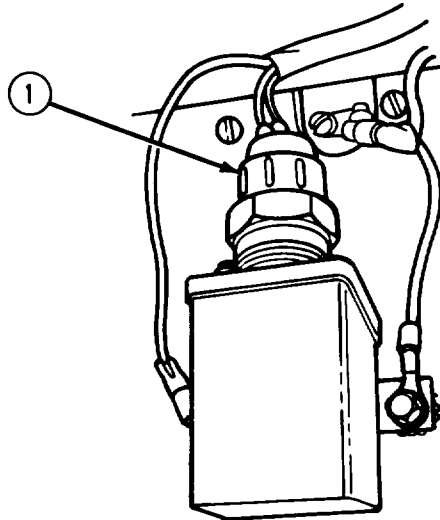
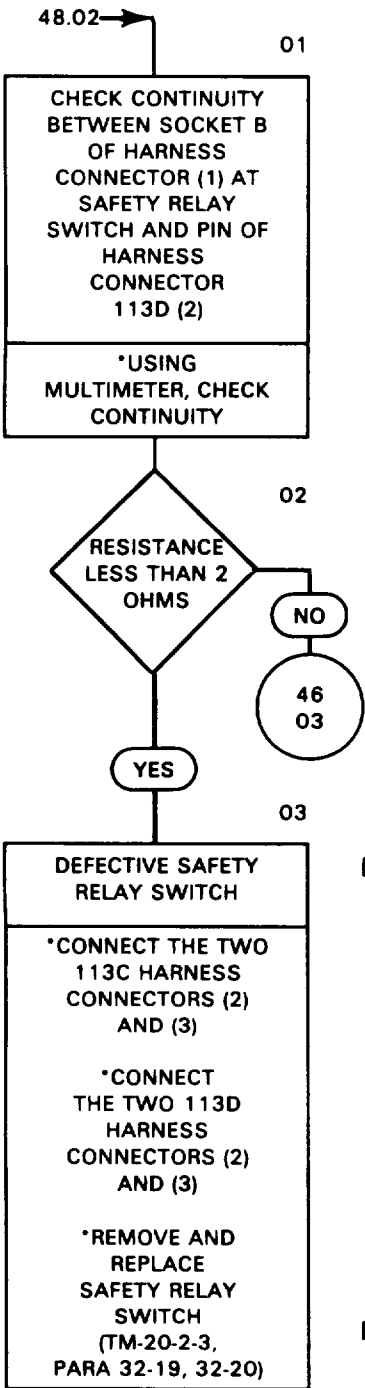

SAFETY RELAY SWITCH AND FIRING CONTACT

3
FEMALE HARNESS CONNECTORS
113C, 113D, AND 113E

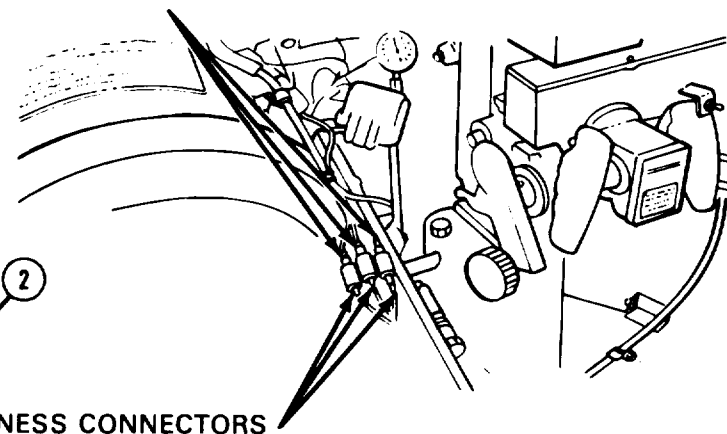

2
MALE HARNESS CONNECTORS
113C, 113D, AND 113E

HARNESS CONNECTORS 113C, 113D, AND 113E

3-3. MAIN GUN FIRING TROUBLESHOOTING (SHEET 48 OF 56)

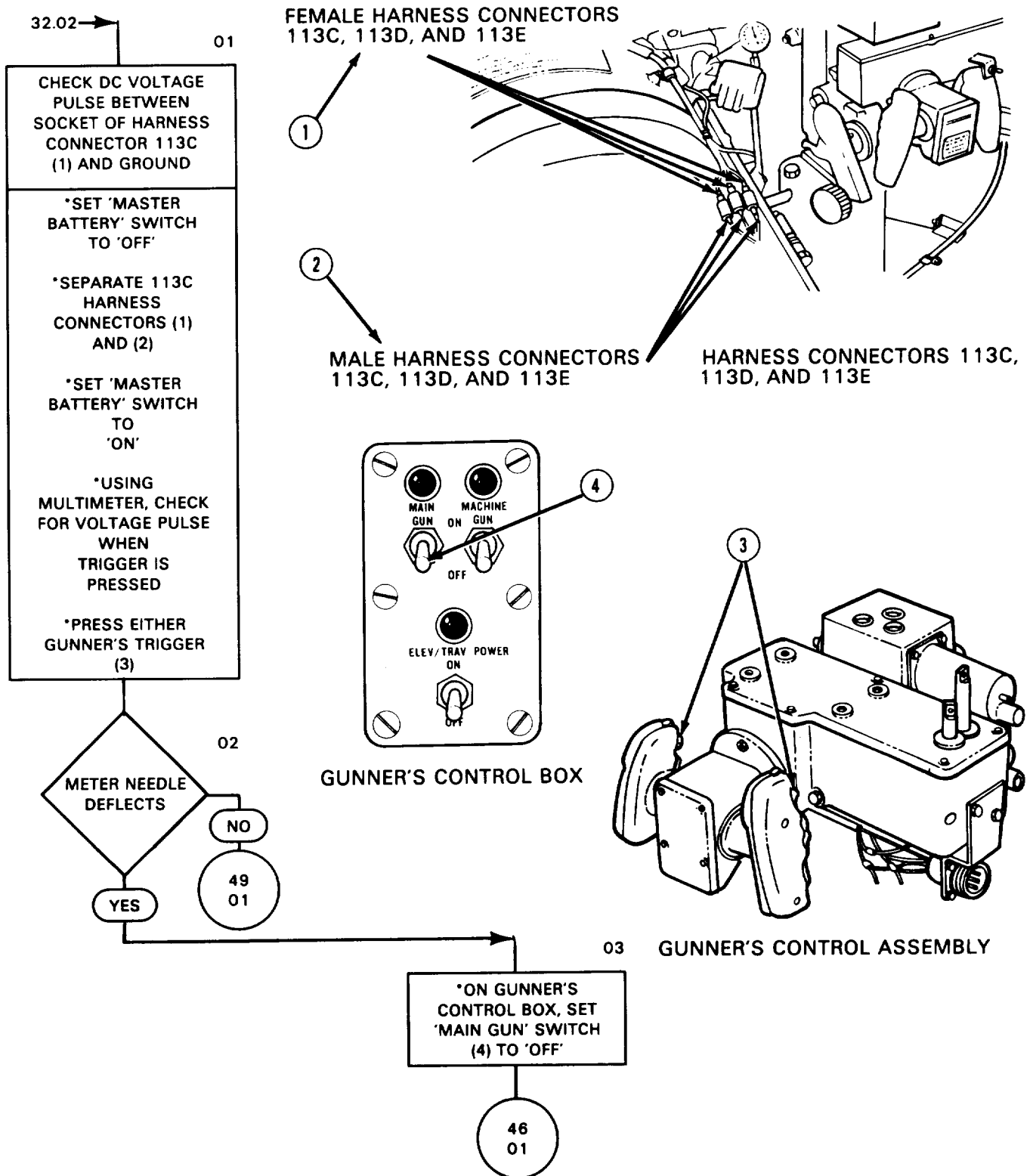

3-3. MAIN GUN FIRING TROUBLESHOOTING (SHEET 49 OF 56)

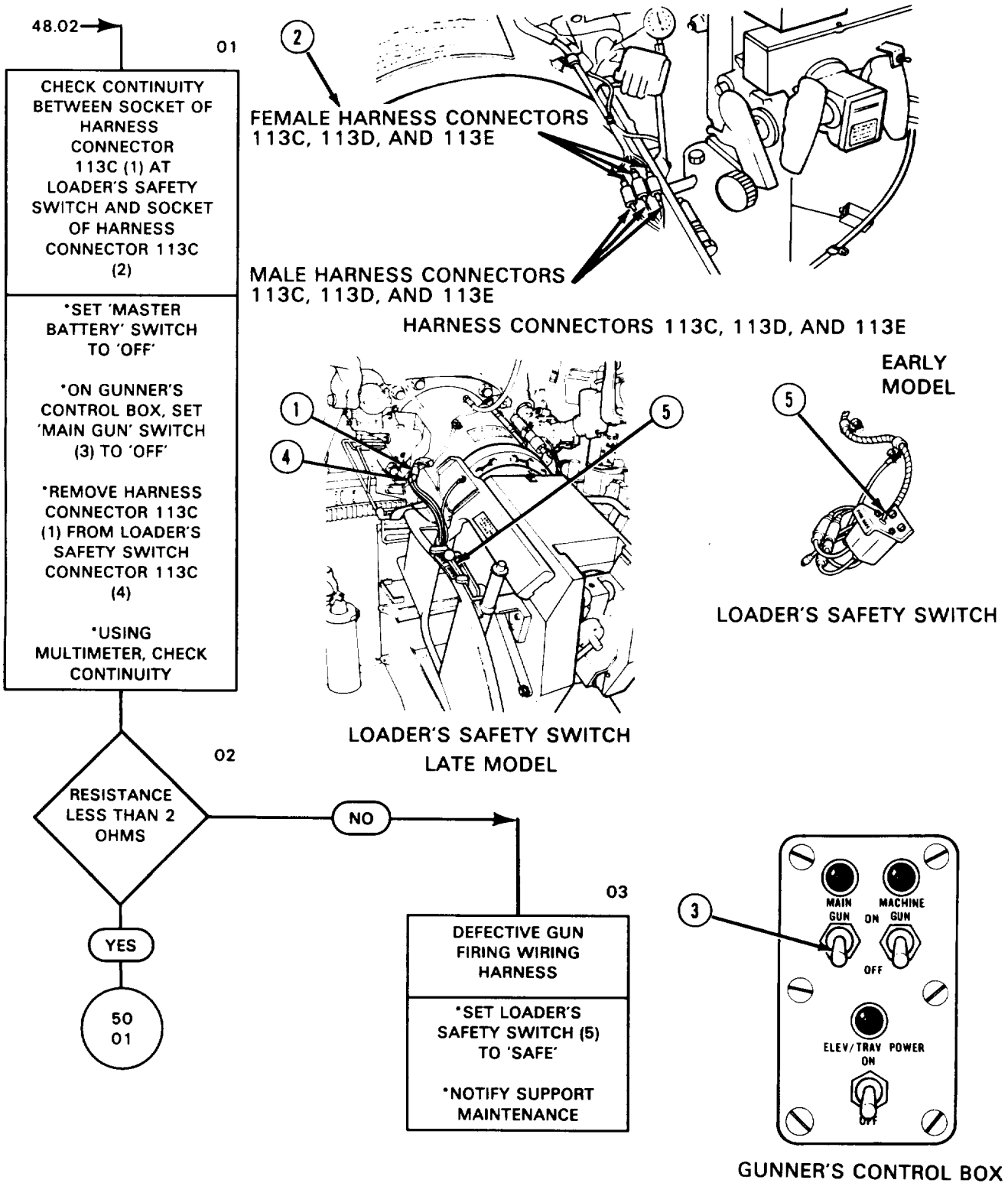

3-3. MAIN GUN FIRING TROUBLESHOOTING (SHEET 50 OF 56)

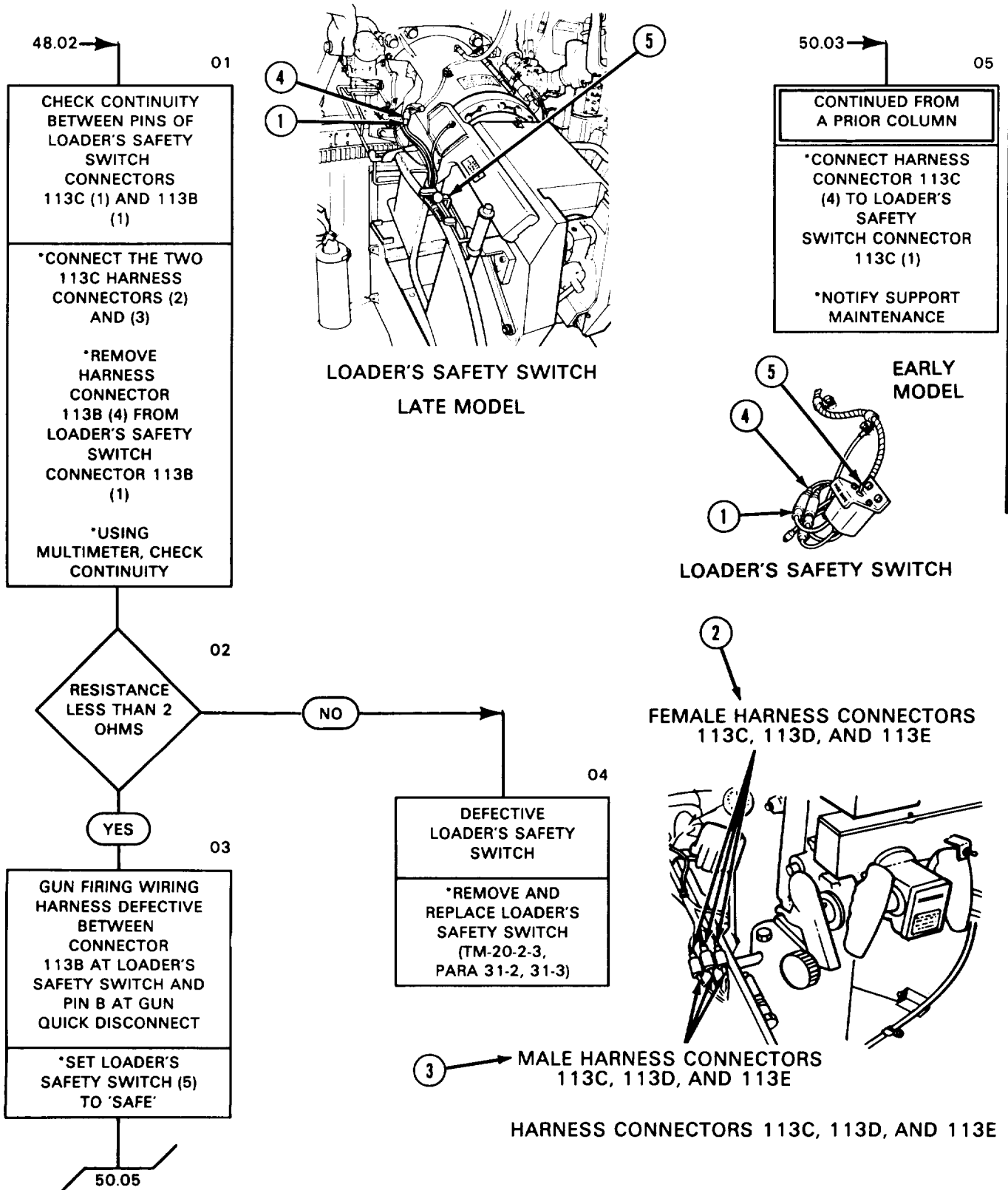

3-3. MAIN GUN FIRING TROUBLESHOOTING (SHEET 51 OF 56)

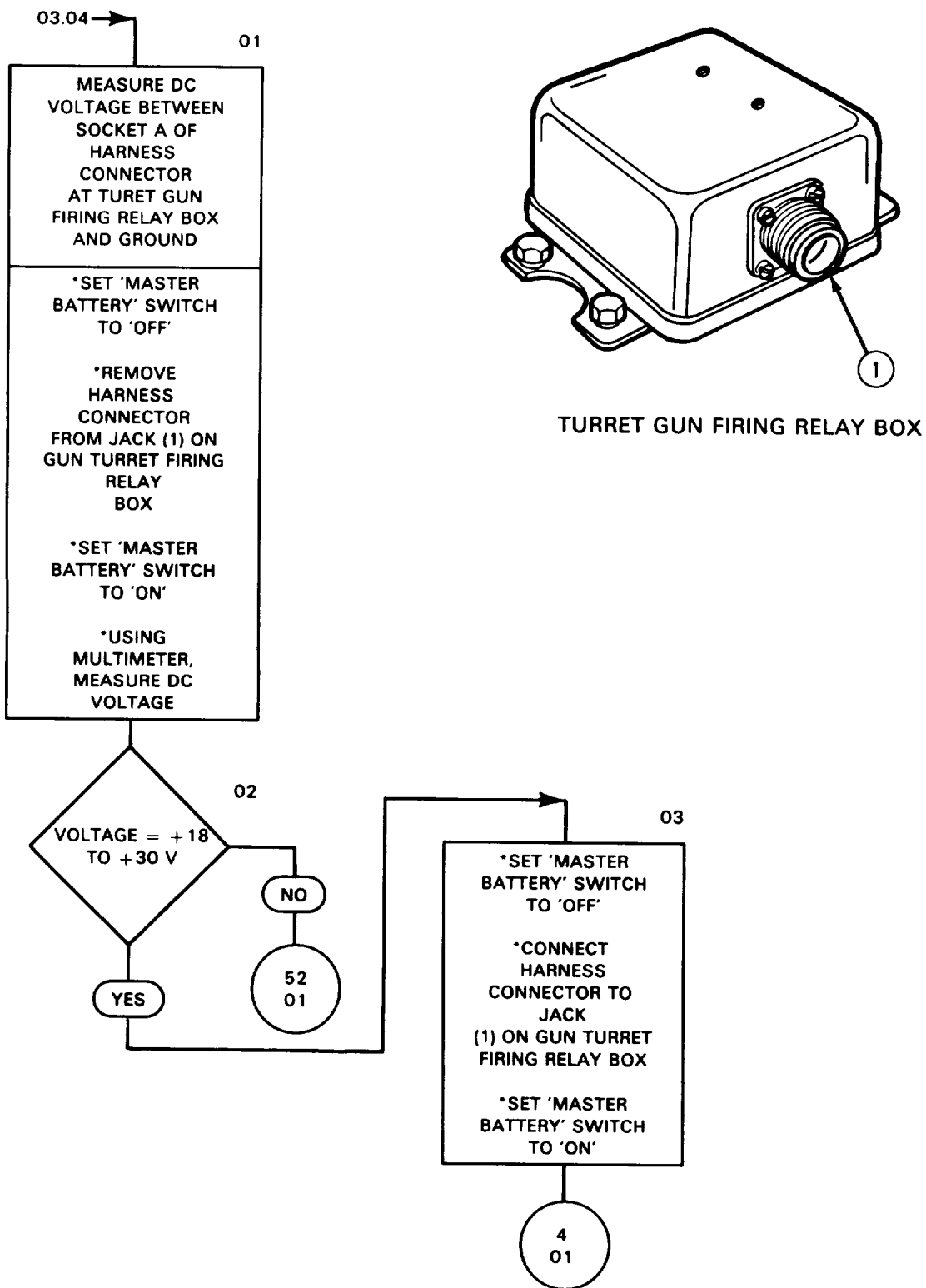

3-3. MAIN GUN FIRING TROUBLESHOOTING (SHEET 52 OF 56)

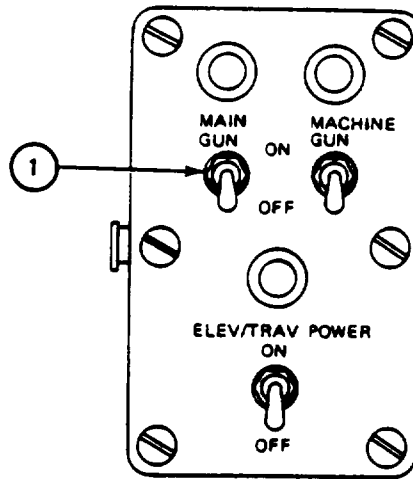
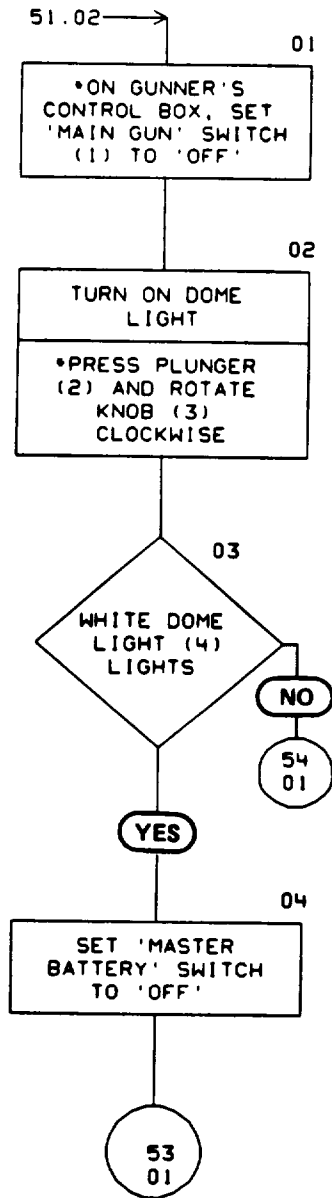

GUNNER'S CONTROL BOX

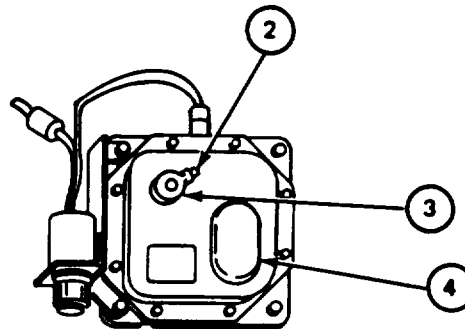

DOME LIGHT AND DIMMER SWITCH

3-3. MAIN GUN FIRING TROUBLESHOOTING (SHEET 53 OF 56)

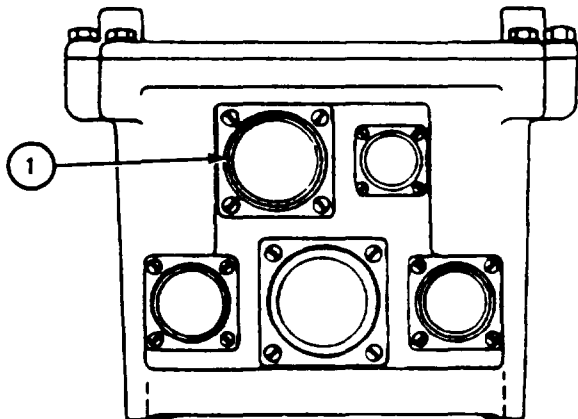
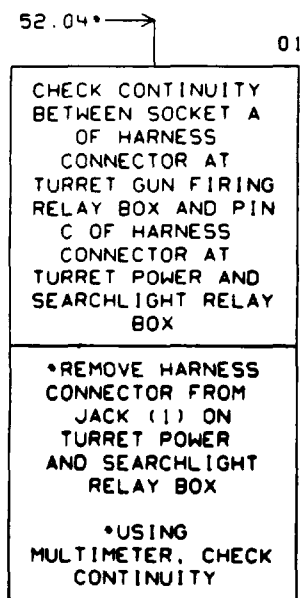

TURRET POWER AND SEARCHLIGHT RELAY BOX

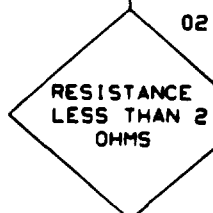

NO

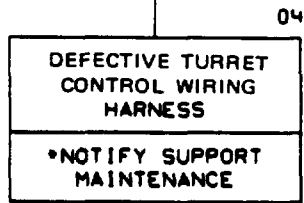

YES

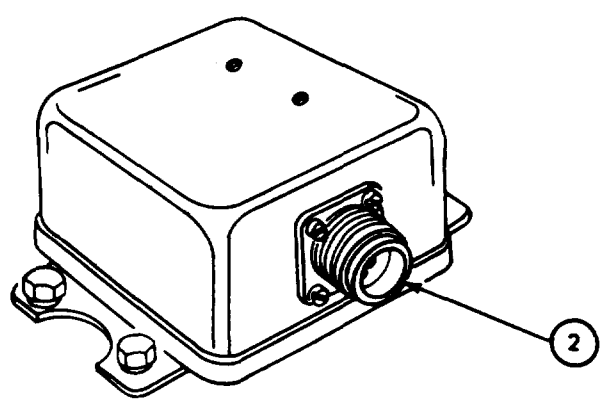

TURRET GUN FIRING RELAY BOX

3-3. MAIN GUN FIRING TROUBLESHOOTING (SHEET 54 OF 56)

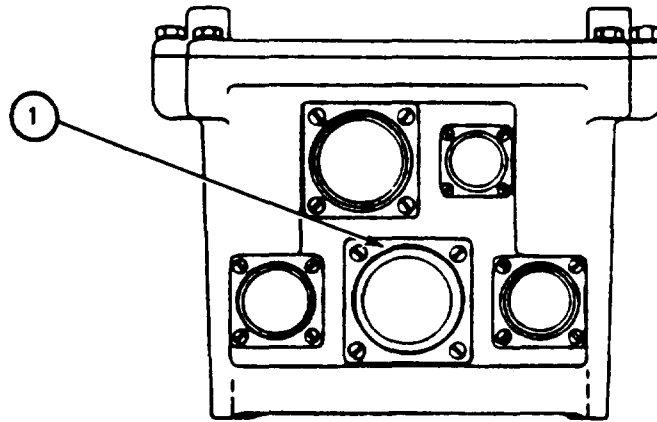
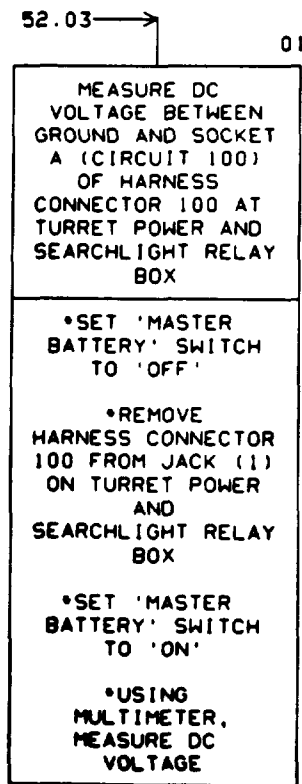

TURRET POWER AND SEARCHLIGHT RELAY BOX

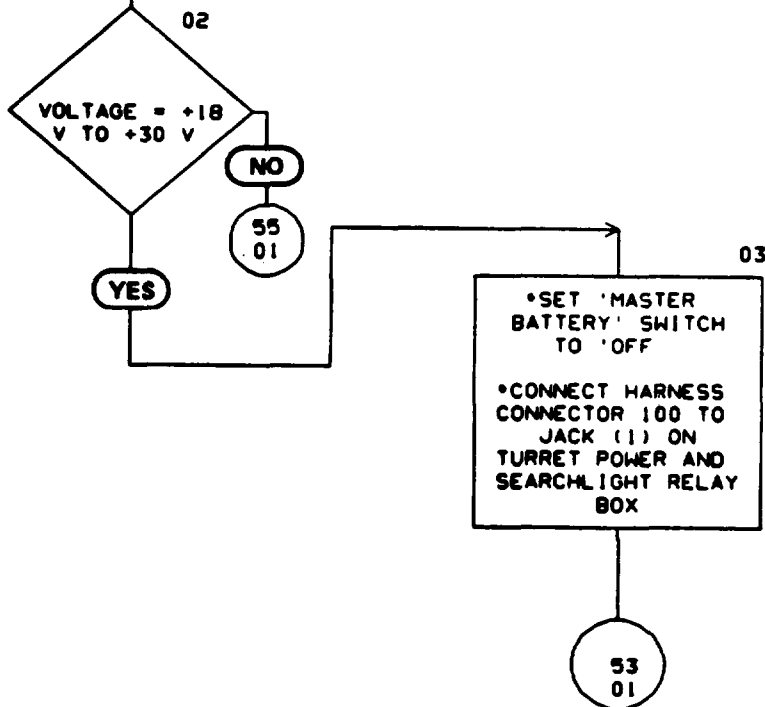

3-3. MAIN GUN FIRING TROUBLESHOOTING (SHEET 55 OF 56)

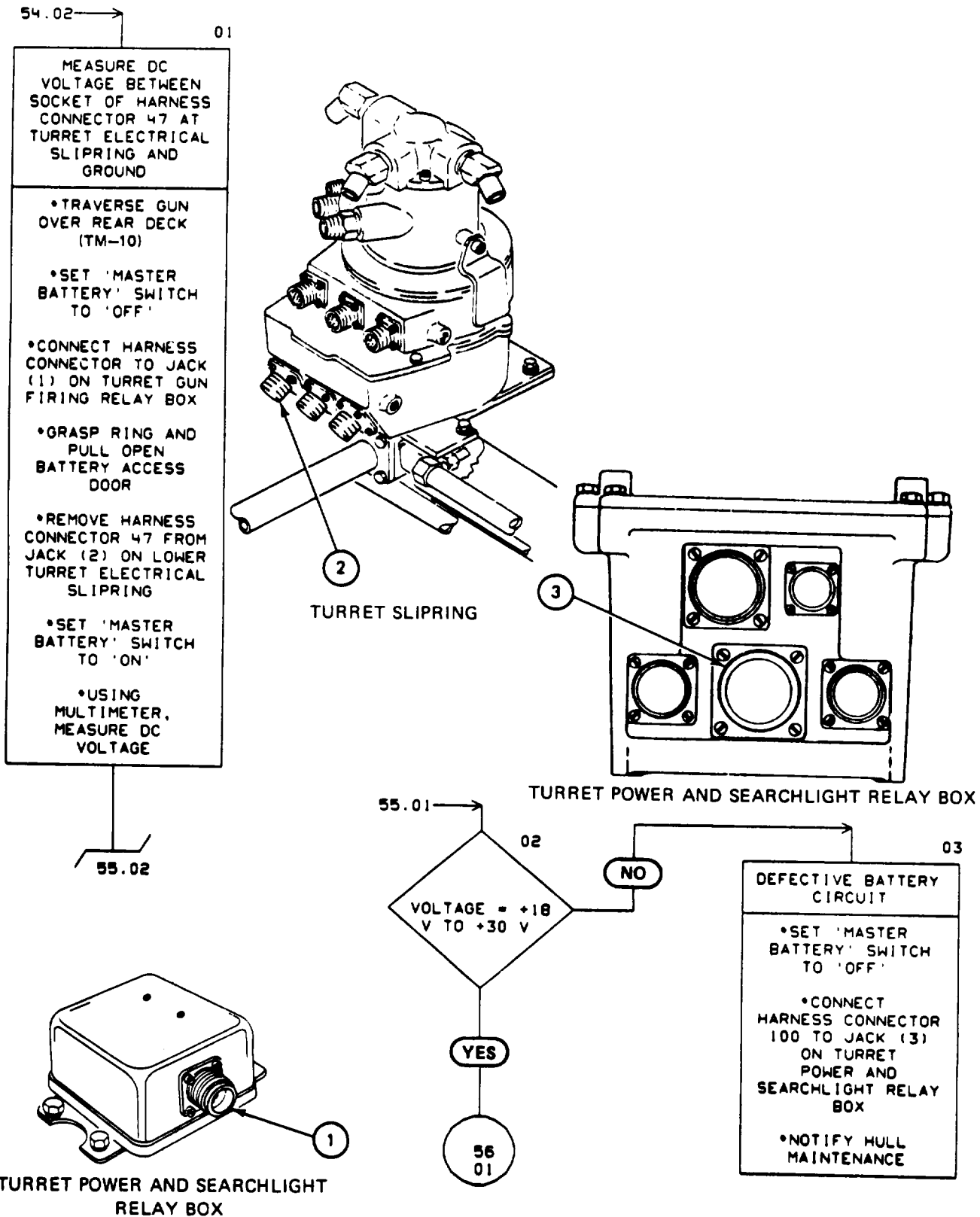

3-3. MAIN GUN FIRING TROUBLESHOOTING (SHEET 56 OF 56)

55.02 →

01

CHECK CONTINUITY BETWEEN SOCKET A OF HARNESS CONNECTOR 100 AT TURRET ELECTRICAL SLIPRING AND SOCKET OF HARNESS CONNECTOR 100 AT UPPER TURRET ELECTRICAL SLIPRING

•SET 'MASTER BATTERY' SWITCH TO 'OFF'

•REMOVE ACCESS COVER FROM TURRET ELECTRICAL SLIPRING (TM-20-2-3 PARA 3-2)

•REMOVE HARNESS CONNECTOR 100 FROM JACK (1) ON UPPER TURRET ELECTRICAL SLIPRING

•USING MULTIMETER, CHECK CONTINUITY

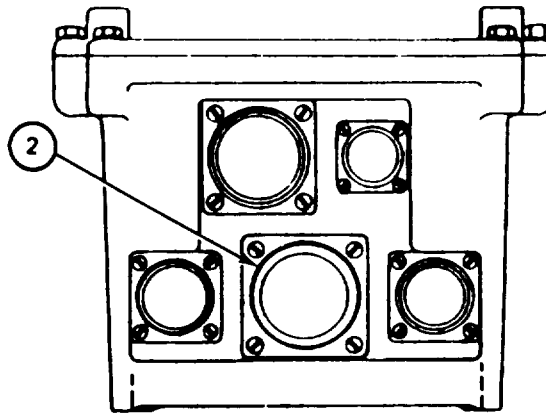

TURRET POWER AND SEARCHLIGHT RELAY BOX

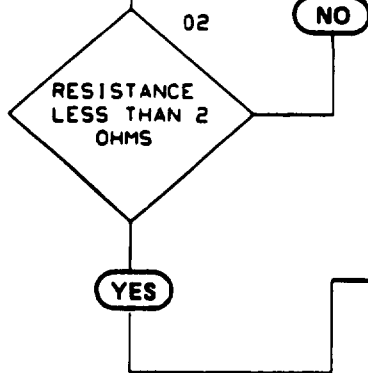

03

DEFECTIVE SLIPRING TO TURRET POWER RELAY BOX WIRING HARNESS

•CONNECT HARNESS CONNECTOR 47 TO JACK (3) ON LOWER TURRET ELECTRICAL SLIPRING

•NOTIFY SUPPORT MAINTENANCE

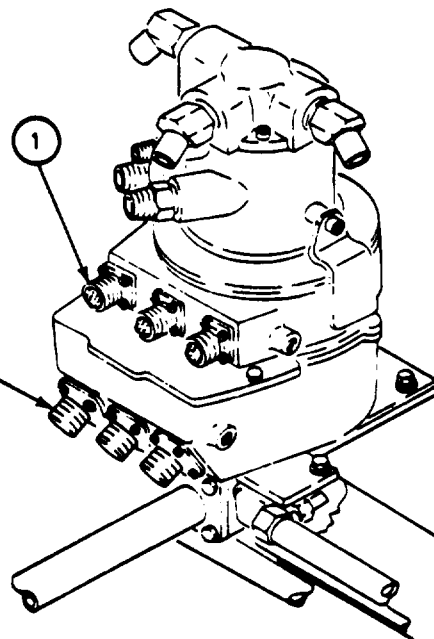

TURRET SLIPRING

04

DEFECTIVE TURRET ELECTRICAL SLIPRING

•CONNECT HARNESS CONNECTOR 100 TO JACK (2) ON TURRET POWER AND SEARCHLIGHT RELAY BOX

•NOTIFY SUPPORT MAINTENANCE

3-4. BLASTING MACHINE TROUBLESHOOTING (SHEET 1 OF 8)

SYMPTOM:

(14) Blasting Machine fails to fire main gun

TEST EQUIPMENT: Multimeter

PERSONNEL: Two

UNIT LOCATION:		FOLDOUT	CALLOUT
	Blasting Machine	1	15
	Loader's Safety Switch	3	6
	Safety Relay Switch	1	12
	Breech Ring	3	4

- REFERENCES:**
- (1) TM 9-2350-222-20-2-3 for removal and replacement of components
 - (2) ETM 643-091-9400-R/JPG for procedures to:
 - Use multimeter
 - Disconnect electrical connectors
 - (3) TM 9-2350-222-10 for procedures to:
 - Remove ammunition
 - Open breech

EQUIPMENT CONDITION: Vehicle parked, power off.

3-4. BLASTING MACHINE TROUBLESHOOTING (SHEET 2 OF 8)

01
WARNING
 TO PREVENT INJURY TO PERSONNEL, REMOVE ALL LIVE AMMUNITION FROM WEAPONS BEFORE START OF TROUBLESHOOTING (TM-10)

02
NOTE
 FOR USE OF MULTIMETER TO MEASURE VOLTAGE, CONTINUITY, OR RESISTANCE, REFER TO JPG

03
MEASURE DC VOLTAGE PULSE FROM BLASTING MACHINE
 *REMOVE BLASTING MACHINE CONNECTORS 113E (1) AND 113G (1) FROM HARNESS CONNECTORS 113E (2) AND 113G (2)
 *CONNECT POSITIVE LEAD OF MULTIMETER TO SOCKET OF BLASTING MACHINE CONNECTOR 113E (1)
 *CONNECT NEGATIVE LEAD OF MULTIMETER TO SOCKET OF BLASTING

NOTE 04
 CONTINUED FROM A PRIOR COLUMN
 MACHINE CONNECTOR 113G (1)
 *USING MULTIMETER, MEASURE DC VOLTAGE PULSE WHILE QUICKLY ROTATING BLASTING MACHINE HANDLE (3) CLOCKWISE
 3.01

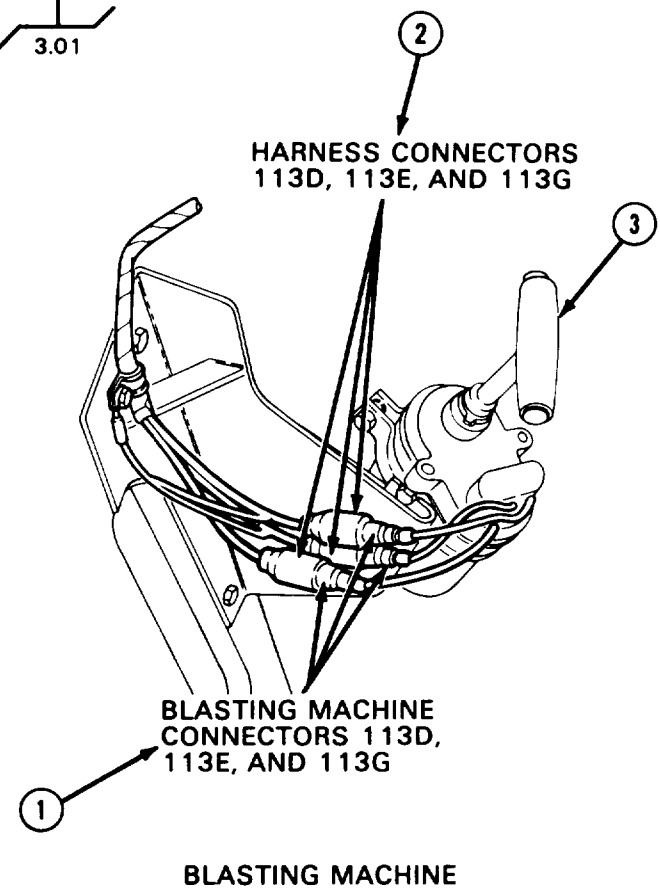

3-4. BLASTING MACHINE TROUBLESHOOTING (SHEET 3 OF 8)

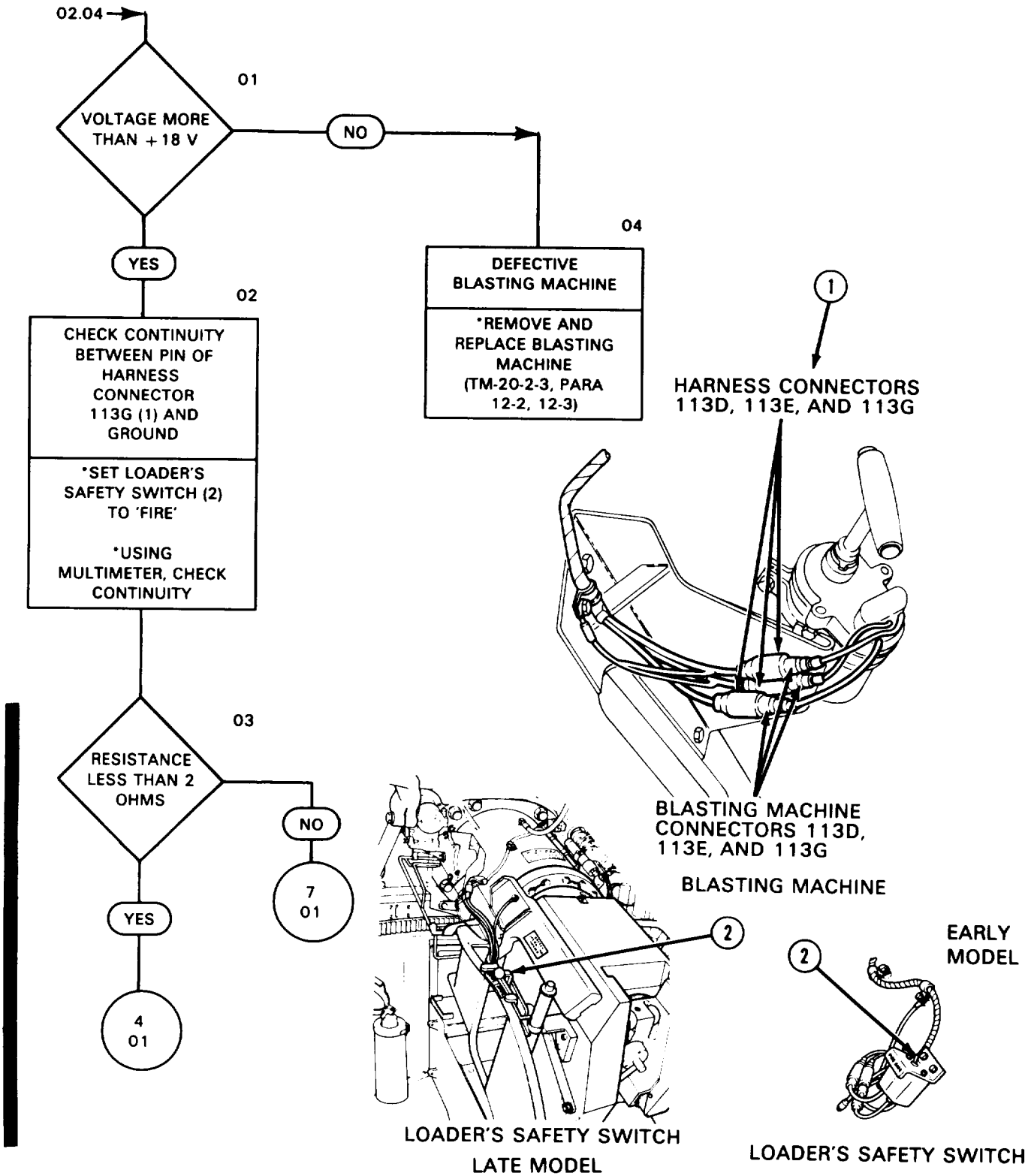

3-4. BLASTING MACHINE TROUBLESHOOTING (SHEET 4 OF 8)

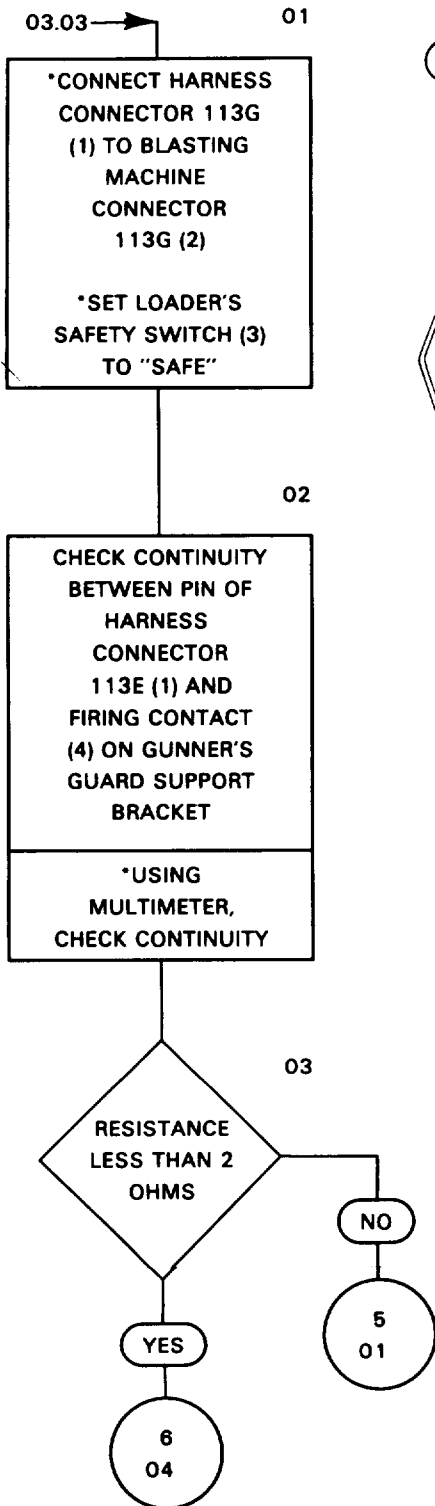

1 HARNESS CONNECTORS 113D, 113E, AND 113G

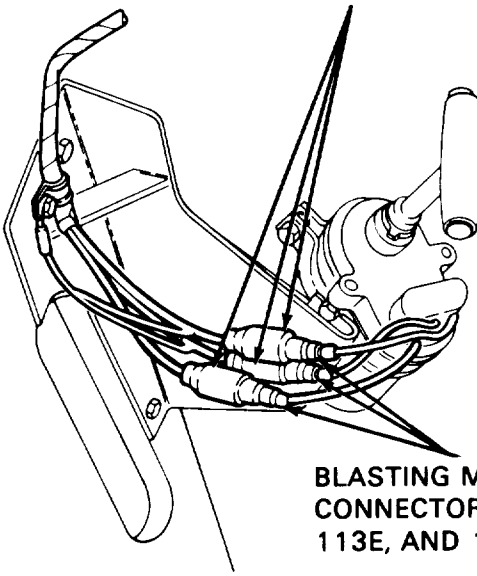

BLASTING MACHINE

2 BLASTING MACHINE CONNECTORS 113D, 113E, AND 113G

EARLY MODEL

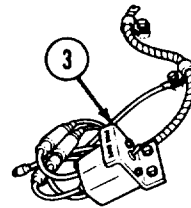

3 LOADER'S SAFETY SWITCH

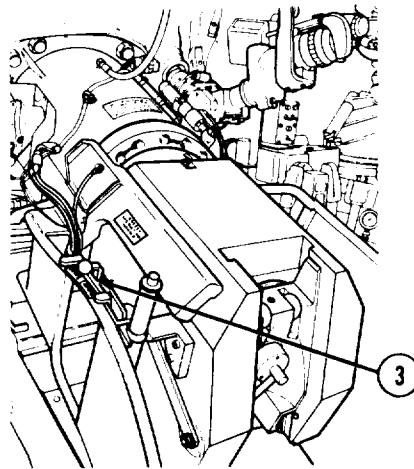

4 LOADER'S SAFETY SWITCH

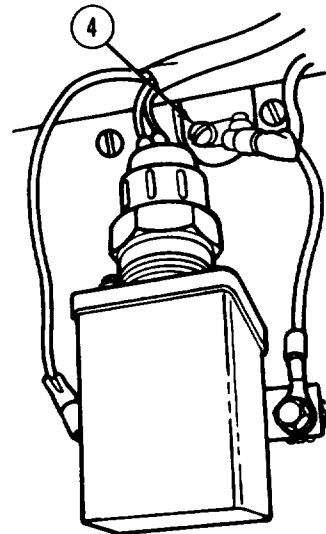

5 SAFETY RELAY SWITCH AND FIRING CONTACT

3-4. BLASTING MACHINE TROUBLESHOOTING (SHEET 5 OF 8)

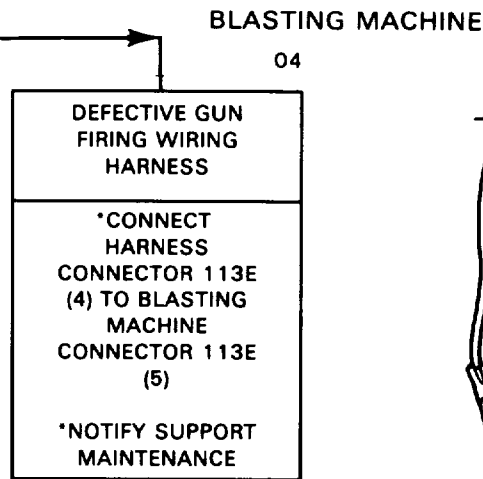
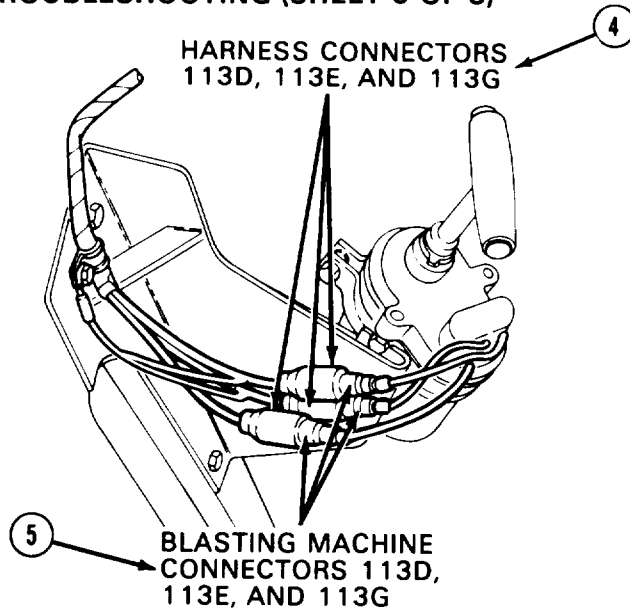
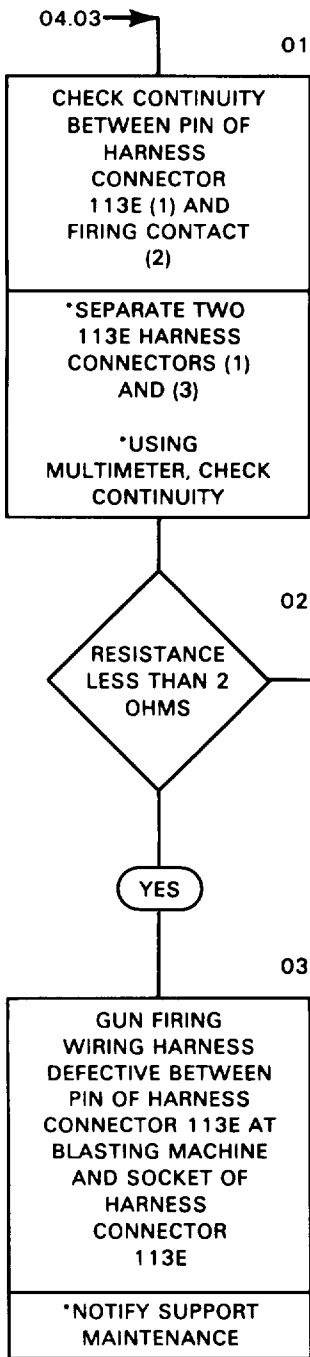

FEMALE HARNESS CONNECTORS 113C, 113D, AND 113E

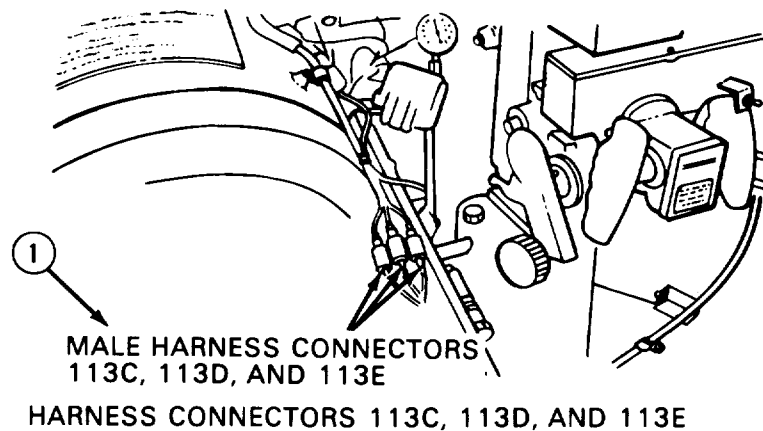
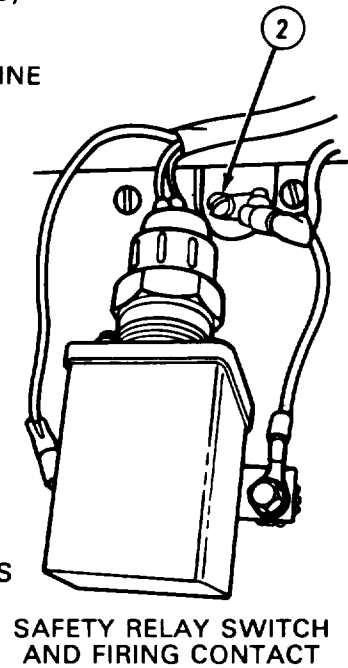

3-4. BLASTING MACHINE TROUBLESHOOTING (SHEET 5 OF 8)

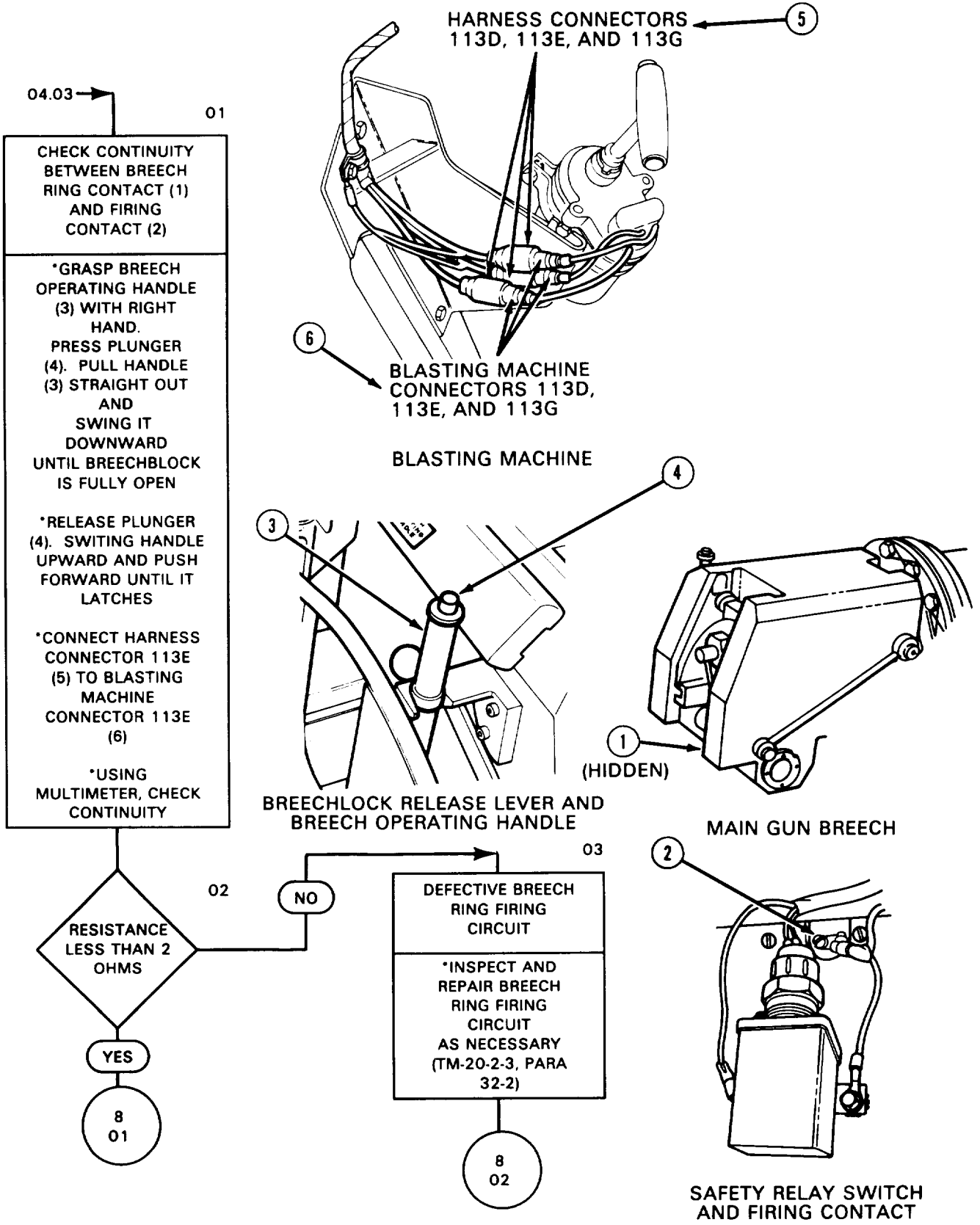

3-4. BLASTING MACHINE TROUBLESHOOTING (SHEET 7 OF 8)

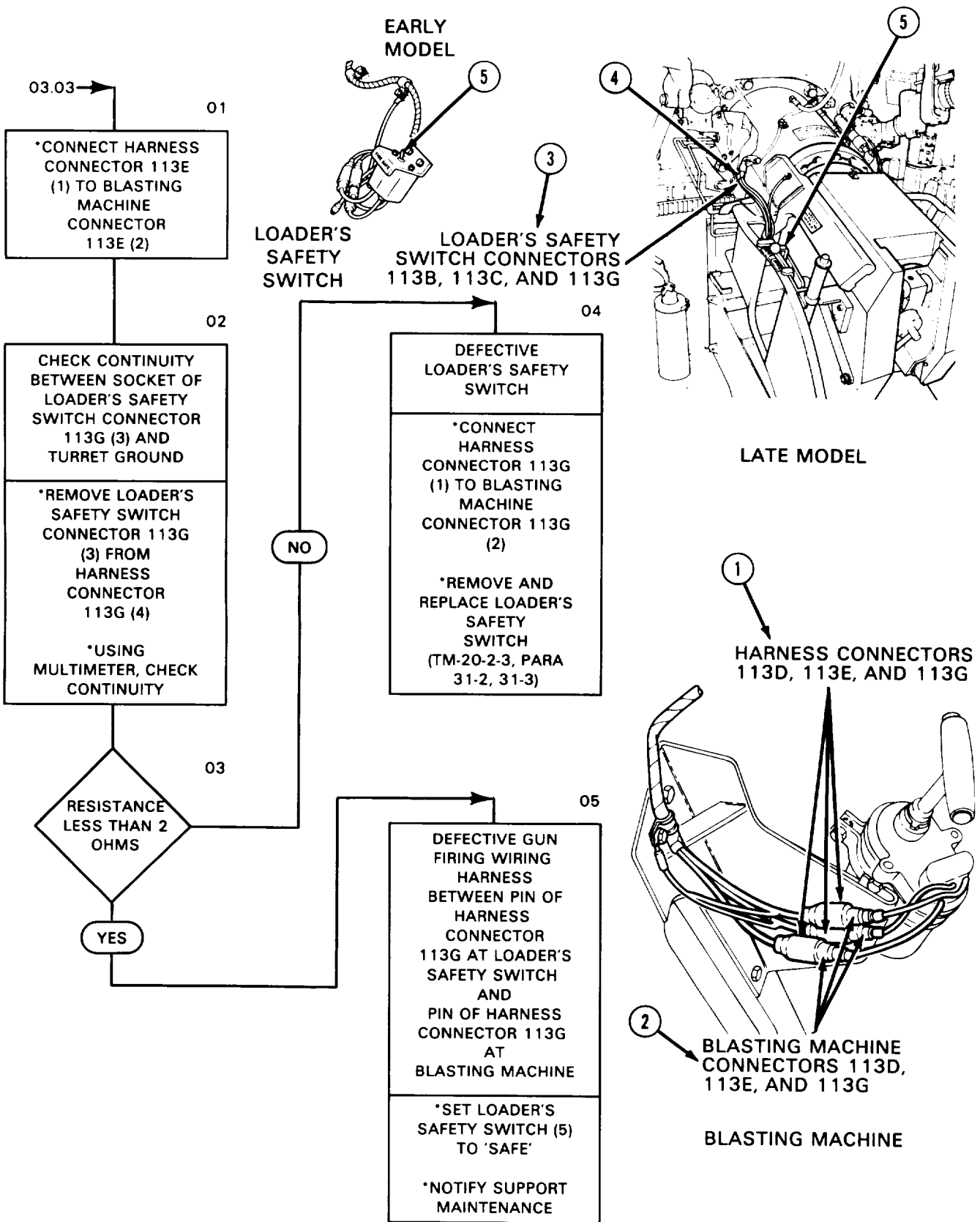

3-4. BLASTING MACHINE TROUBLESHOOTING (SHEET 8 OF 8)

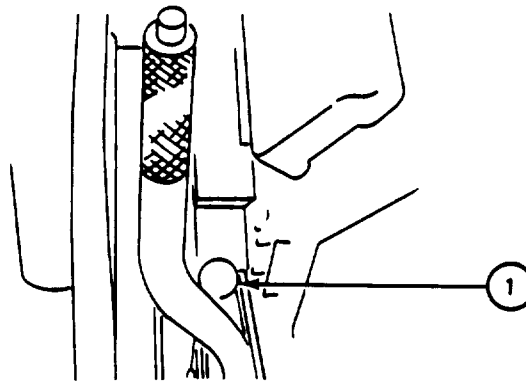
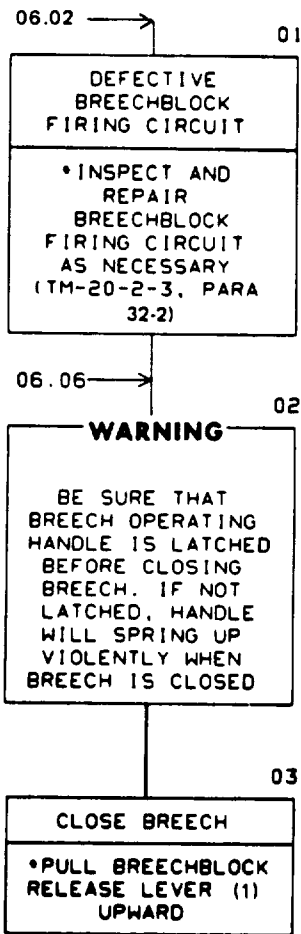

**BREECHLOCK RELEASE LEVER AND
BREECH OPERATING HANDLE**

3-5. MACHINE GUN AND MAIN GUN LAMP TROUBLESHOOTING (SHEET 1 OF 10)

SYMPTOM:

- (5) MACHINE GUN lamp on Gunner's Control Box fails to light
- (13) MAIN GUN lamp on Gunner's Control Box fails to light

TEST EQUIPMENT: Multimeter

PERSONNEL: Two

UNIT LOCATION:	FOLDOUT	CALLOUT
Master Control Panel	4	4
Gunner's Control Box	1	2
Gunner's Dome Light	1	1
Turret Power and Searchlight Relay Box	1	9
Turret Electrical Slipring	3	5

- REFERENCES:**
- (1) TM 9-2350-222-20-2-3 for removal and replacement of components
 - (2) ETM 643-091-9400-R/JPG for procedures to:
Use multimeter
Disconnect electrical connectors
 - (3) TM 9-2350-222-10 for procedures to:
Remove ammunition
Traverse turret

EQUIPMENT CONDITION: Vehicle parked, power off.

3-5. MACHINE GUN OR MAIN GUN LAMP TROUBLESHOOTING (SHEET 2 OF 10)

WARNING 01
 TO PREVENT INJURY TO PERSONNEL, REMOVE ALL LIVE AMMUNITION FROM WEAPONS BEFORE START OF TROUBLESHOOTING (TM-10)

CAUTION 02
 TO PREVENT EQUIPMENT DAMAGE, TURN OFF POWER BEFORE REMOVING COVERS OR HARNESS CONNECTORS AND BEFORE MEASURING CONTINUITY OR RESISTANCE. AFTER MEASUREMENT, TURN POWER BACK ON.

NOTE 03
 FOR USE OF MULTIMETER TO MEASURE VOLTAGE, CONTINUITY, OR RESISTANCE, REFER TO JPG

04
 *ON MASTER CONTROL PANEL, SET 'MASTER BATTERY' SWITCH (1) TO 'ON'

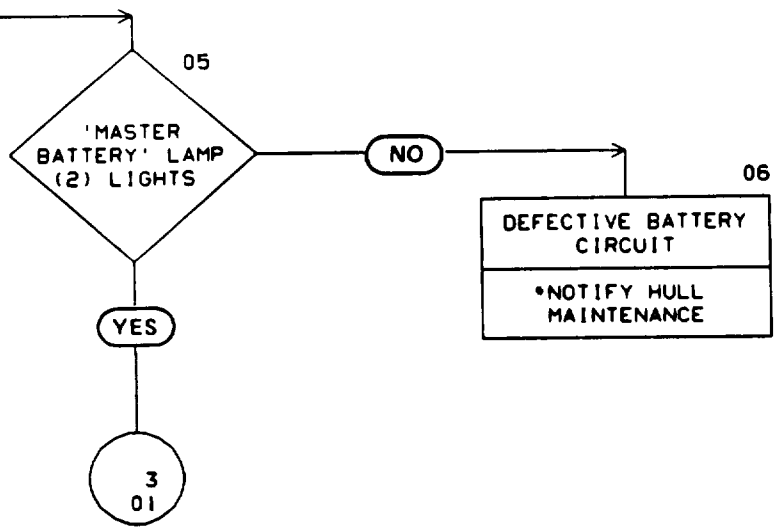
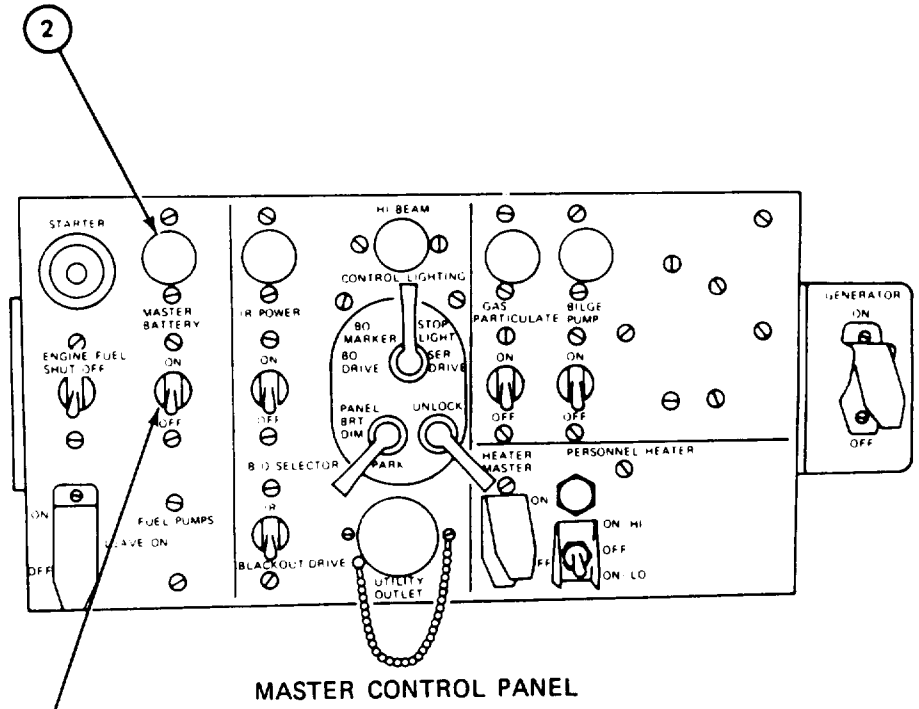

3-5. MACHINE GUN OR MAIN GUN LAMP TROUBLESHOOTING (SHEET 3 OF 10)

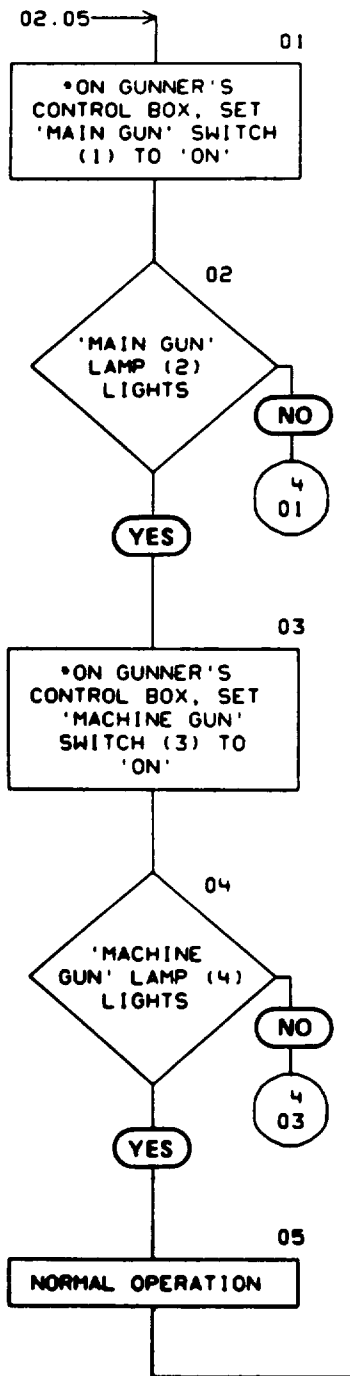

NOTE 06

CONTINUED FROM A PRIOR COLUMN

*SET 'MASTER BATTERY' SWITCH TO 'OFF'

*ON GUNNER'S CONTROL BOX, SET 'MAIN GUN' (1) AND 'MACHINE GUN' (3) SWITCHES TO 'OFF'

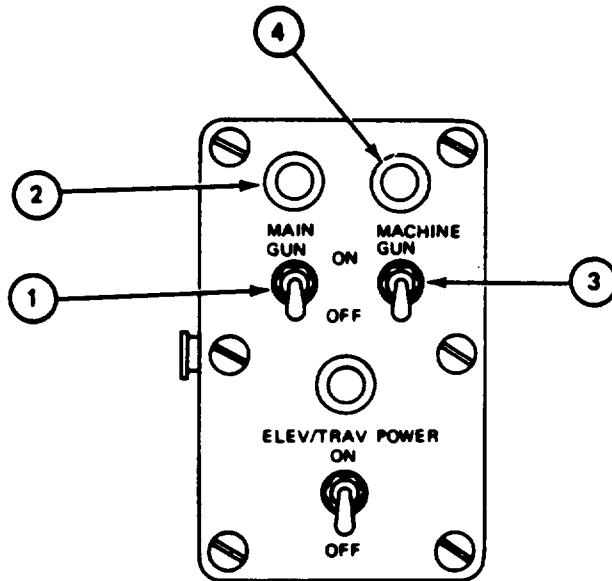

GUNNER'S CONTROL BOX

3-5. MACHINE GUN OR MAIN GUN LAMP TROUBLESHOOTING (SHEET 4 OF 10)

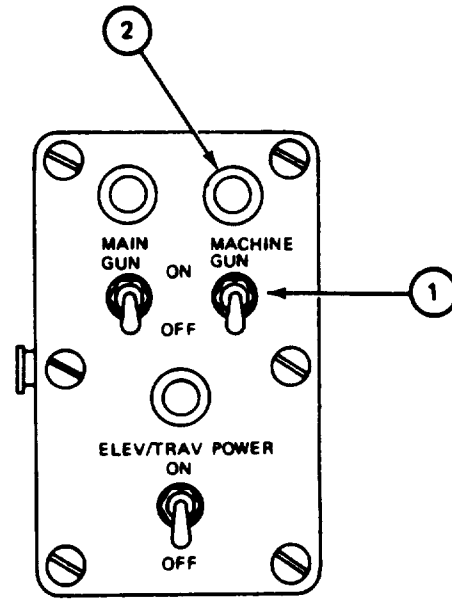
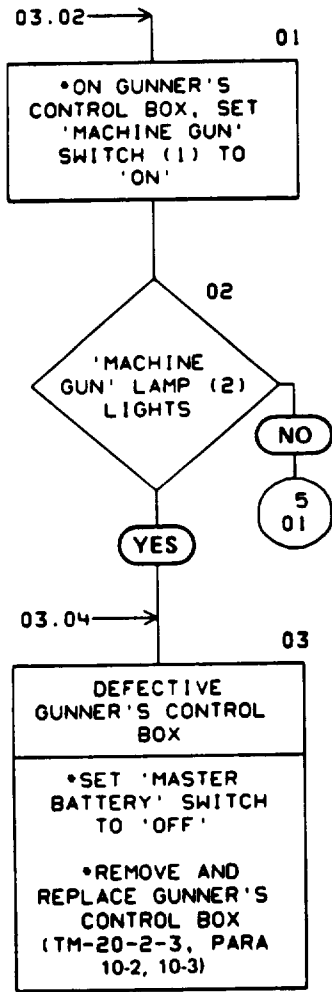

GUNNER'S CONTROL BOX

3-5. MACHINE GUN OR MAIN GUN LAMP TROUBLESHOOTING (SHEET 5 OF 10)

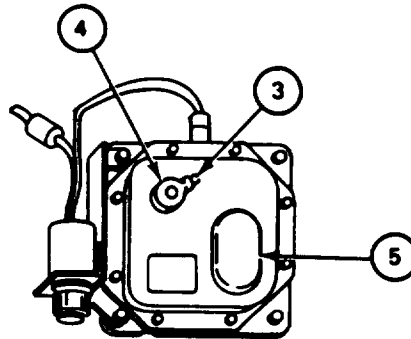
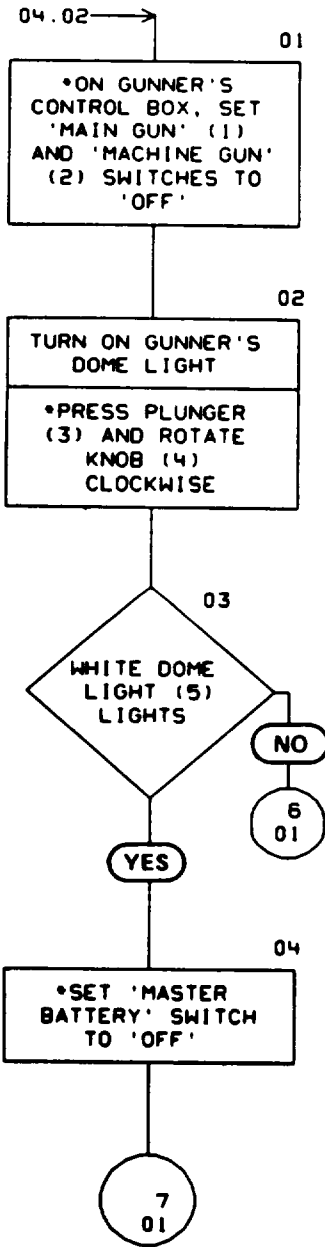

DOME LIGHT AND DIMMER SWITCH

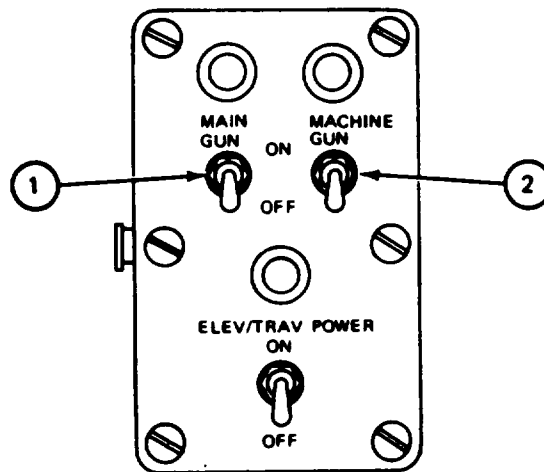

GUNNER'S CONTROL BOX

3-5. MACHINE GUN OR MAIN GUN LAMP TROUBLESHOOTING (SHEET 6 OF 10)

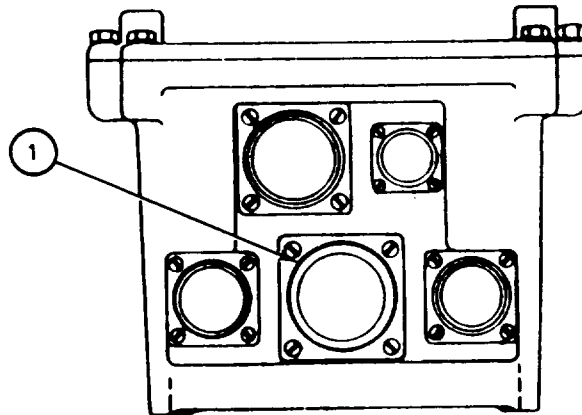
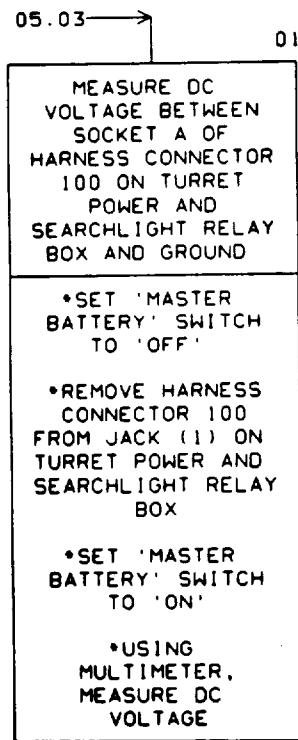

TURRET POWER AND SEARCHLIGHT RELAY BOX

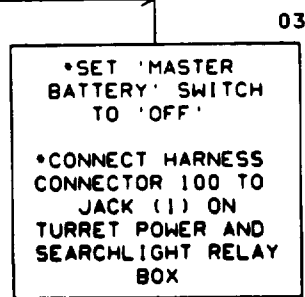
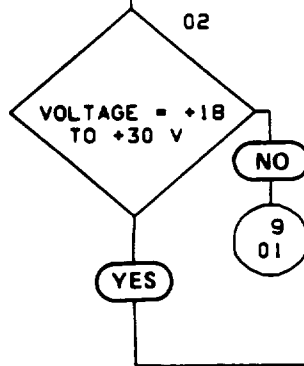

7.01

3-5. MACHINE GUN OR MAIN GUN LAMP TROUBLESHOOTING (SHEET 7 OF 10)

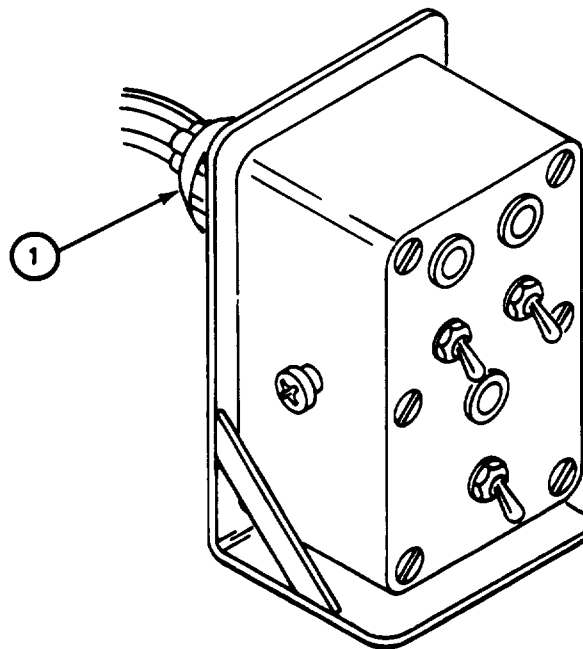
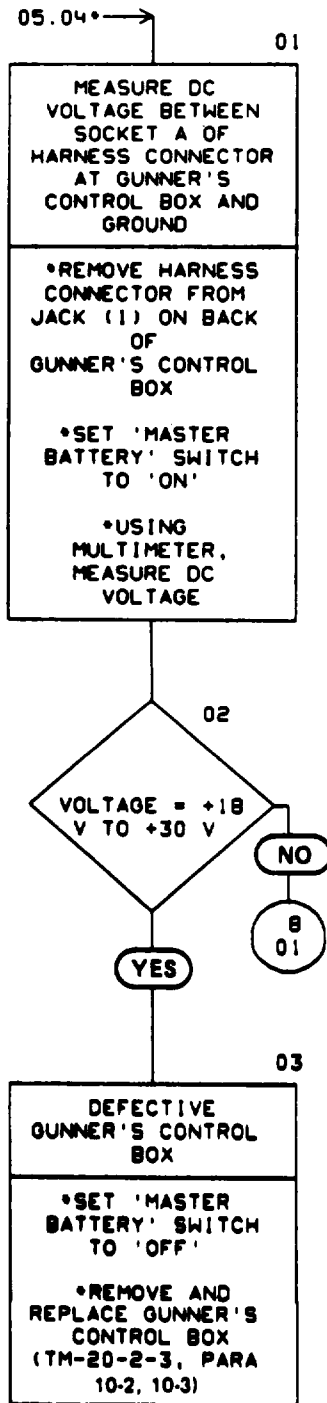

GUNNER'S CONTROL BOX

3-5. MACHINE GUN OR MAIN GUN LAMP TROUBLESHOOTING (SHEET 8 OF 10)

07.02 →

01

CHECK CONTINUITY BETWEEN SOCKET A OF HARNESS CONNECTOR AT GUNNER'S CONTROL BOX AND PIN C OF HARNESS CONNECTOR AT TURRET POWER AND SEARCHLIGHT RELAY BOX

• SET 'MASTER BATTERY' SWITCH TO 'OFF'

• REMOVE HARNESS CONNECTOR FROM JACK (1) ON TURRET POWER AND SEARCHLIGHT RELAY BOX

• USING MULTIMETER, CHECK CONTINUITY

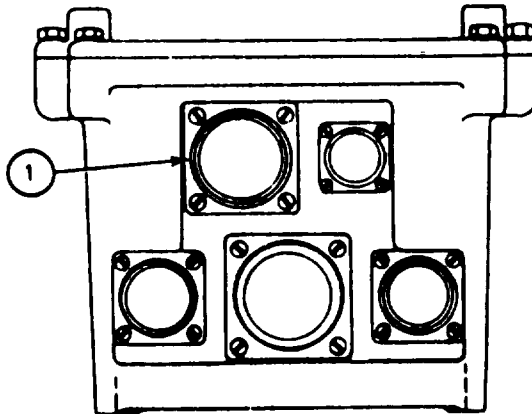

TURRET POWER AND SEARCHLIGHT RELAY BOX

02

RESISTANCE LESS THAN 2 OHMS

YES

NO

04

DEFECTIVE TURRET CONTROL WIRING HARNESS

• NOTIFY SUPPORT MAINTENANCE

03

DEFECTIVE TURRET POWER AND SEARCHLIGHT RELAY BOX

• CONNECT HARNESS CONNECTOR TO JACK (2) ON BACK OF GUNNER'S CONTROL BOX

• REMOVE AND REPLACE TURRET POWER AND SEARCHLIGHT RELAY BOX (TM-20-2-3, PARA 9-2, 9-3)

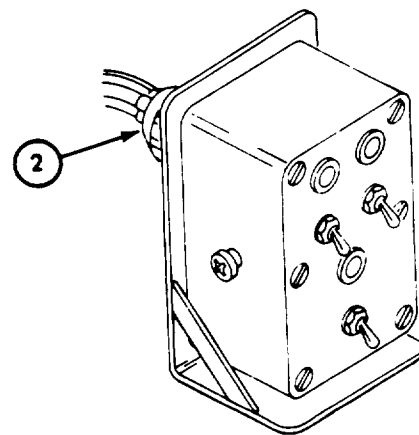

GUNNER'S CONTROL BOX

3-5. MACHINE GUN OR MAIN GUN LAMP TROUBLESHOOTING (SHEET 9 OF 10)

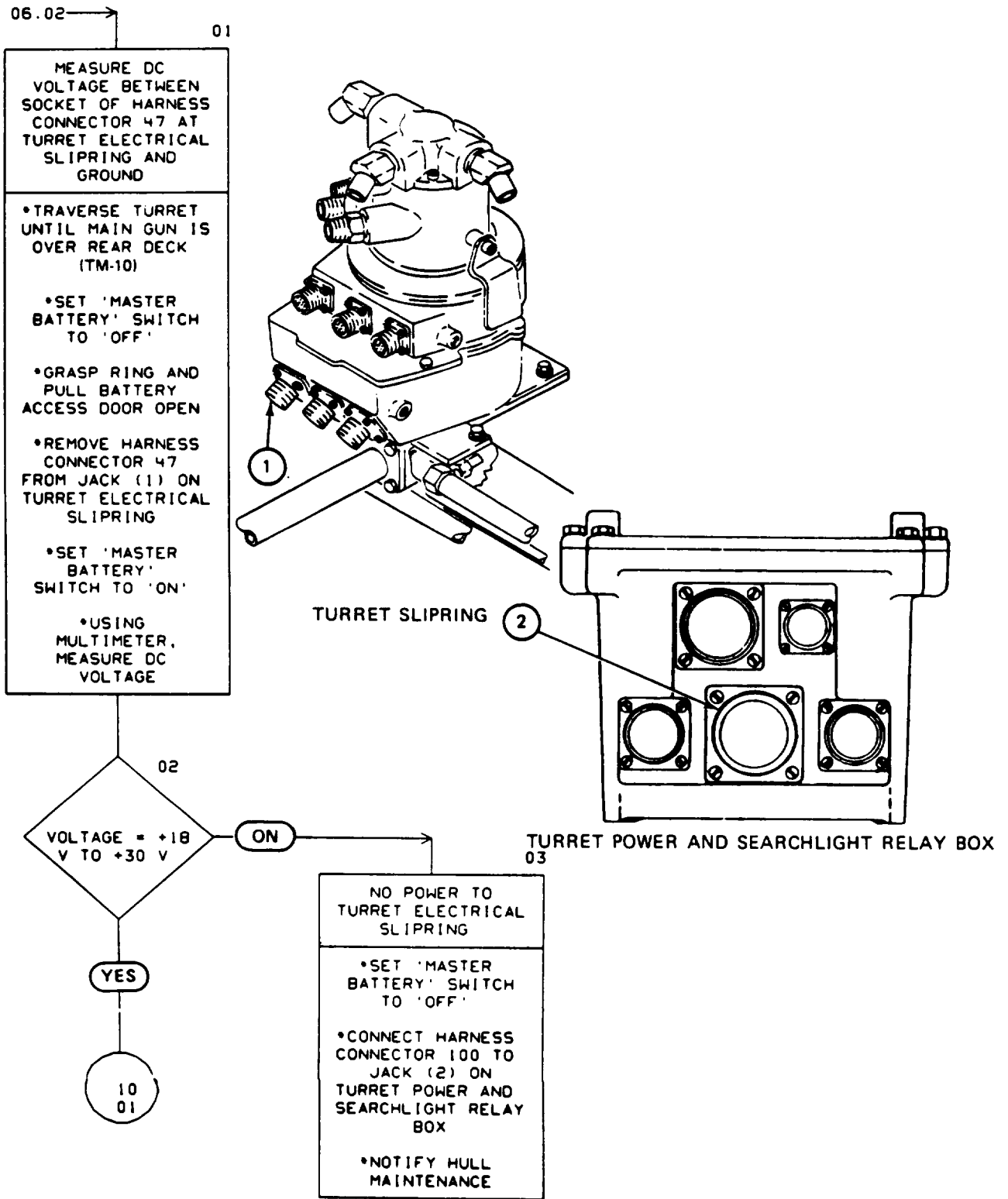

3-5. MACHINE GUN OR MAIN GUN LAMP TROUBLESHOOTING (SHEET 10 OF 10)

09.02 →

01

CHECK CONTINUITY BETWEEN PIN OF HARNESS CONNECTOR 100 AT TURRET ELECTRICAL SLIPRING AND SOCKET A OF HARNESS CONNECTOR 100 AT TURRET POWER AND SEARCHLIGHT RELAY BOX

- SET 'MASTER BATTERY' SWITCH TO 'OFF'
- REMOVE COVER FROM TURRET ELECTRICAL SLIPRING (TM-20-2-3, PARA 3-2)
- REMOVE HARNESS CONNECTOR 100 FROM JACK (1) ON TURRET ELECTRICAL SLIPRING
- USING MULTIMETER, CHECK CONTINUITY

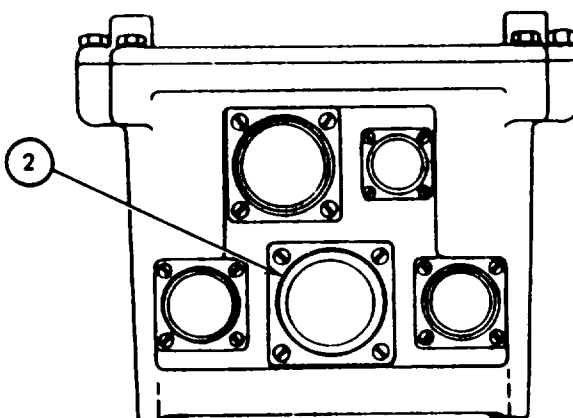

TURRET POWER AND SEARCHLIGHT RELAY BOX

02

RESISTANCE LESS THAN 2 OHMS

YES

NO

03

DEFECTIVE SLIPRING TO TURRET POWER RELAY BOX WIRING HARNESS

- CONNECT HARNESS CONNECTOR 47 TO JACK (3) ON LOWER TURRET ELECTRICAL SLIPRING
- NOTIFY SUPPORT MAINTENANCE

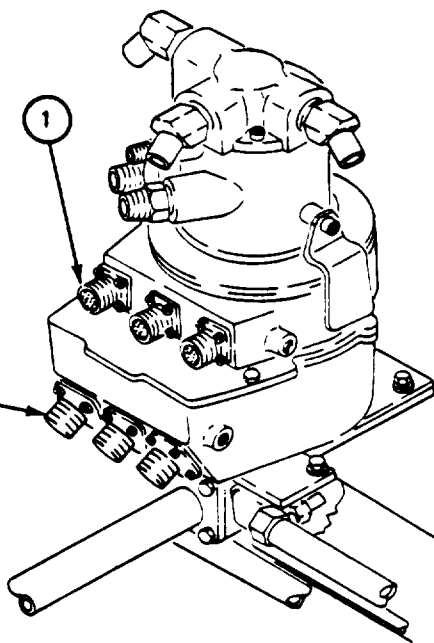

TURRET SLIPRING

04

DEFECTIVE TURRET ELECTRICAL SLIPRING

- CONNECT HARNESS CONNECTOR 100 TO JACK (2) ON TURRET POWER AND SEARCHLIGHT RELAY BOX
- REMOVE AND REPLACE TURRET ELECTRICAL SLIPRING (TM-20-2-3, PARA 3-7, 3-8)

3-6. CALIBER .50 MACHINE GUN TROUBLESHOOTING (LAST ROUND STOP INSTALLED) (SHEET 1 OF 29)

SYMPTOM: (7) Caliber .50 machine gun fails to fire

TEST EQUIPMENT: Multimeter

PERSONNEL: Two

UNIT LOCATION:	FOLDOUT	CALLOUT
Master Control Panel	4	4
Commander's Control Panel	2	15
Cupola Power Switch	2	1
Elevating Handle	2	18
Caliber .50 Machine Gun	2	16
Cupola Power Relay	2	1
Cupola Interconnecting Box	2	6
Turret Power and Searchlight Relay Box	1	9
Gunner's Dome Light	1	1
Turret Electrical Slipping	3	5

- REFERENCES:** (1) TM 9-2350-222-20-2-3 for removal and replacement of components
(2) ETM 643-091-9400-R/JPG for procedures to:
Use multimeter
Disconnect electrical connectors
(3) TM 9-2350-222-10 for procedures to:
Remove ammunition

EQUIPMENT CONDITION: Vehicle parked, power off.

3-6. CALIBER .50 MACHINE GUN TROUBLESHOOTING-LAST ROUND STOP INSTALLED (SHEET 2 OF 29)

01
WARNING
 TO PREVENT INJURY TO PERSONNEL, REMOVE ALL AMMUNITION FROM WEAPONS BEFORE START OF TROUBLESHOOTING (TM-10)

02
CAUTION
 TO PREVENT EQUIPMENT DAMAGE, TURN OFF POWER BEFORE REMOVING COVERS OR HARNESS CONNECTORS AND BEFORE MEASURING RESISTANCE OR CONTINUITY

03
NOTE
 FOR USE OF MULTIMETER TO MEASURE VOLTAGE, CONTINUITY OR RESISTANCE, REFER TO JPG

04
 *SET 'MASTER BATTERY' SWITCH (1) ON MASTER CONTROL PANEL TO 'ON'

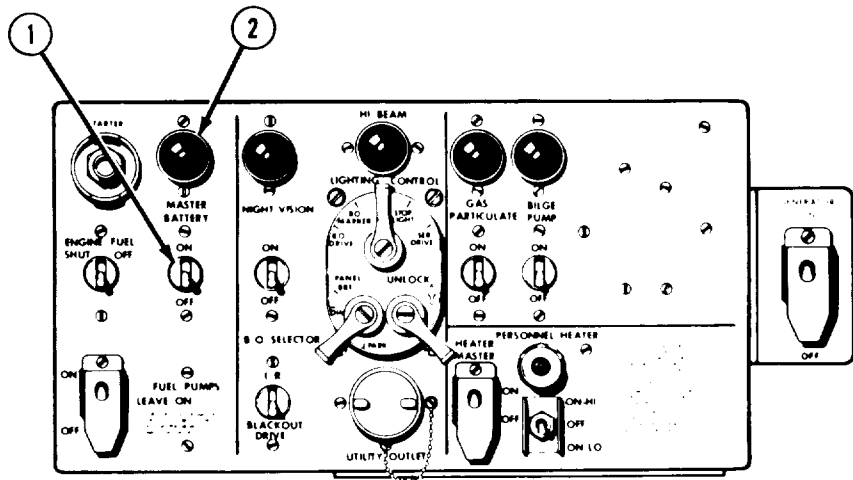

MASTER CONTROL PANEL

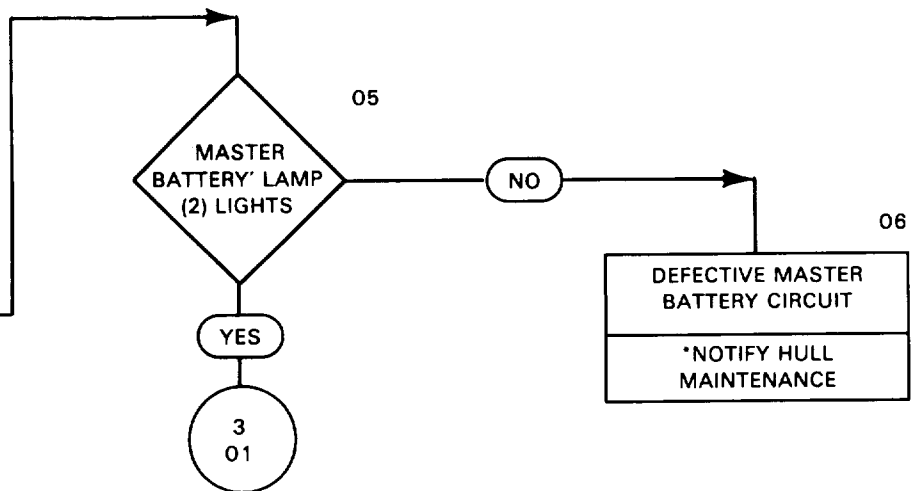

3-6. CALIBER .50 MACHINE GUN TROUBLESHOOTING-LAST ROUND STOP INSTALLED (SHEET 3 OF 29)

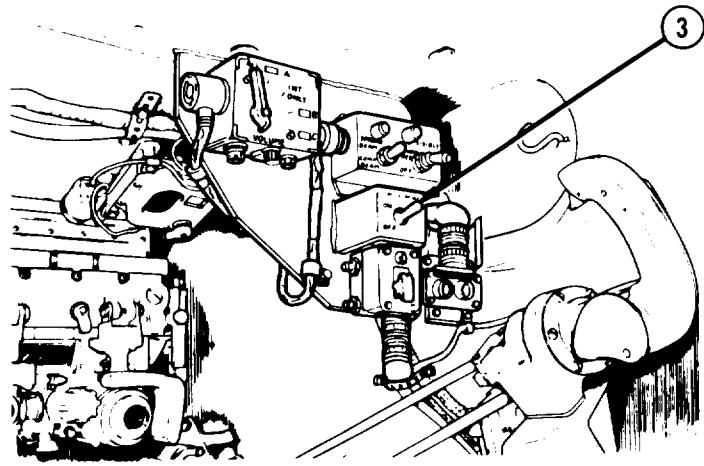
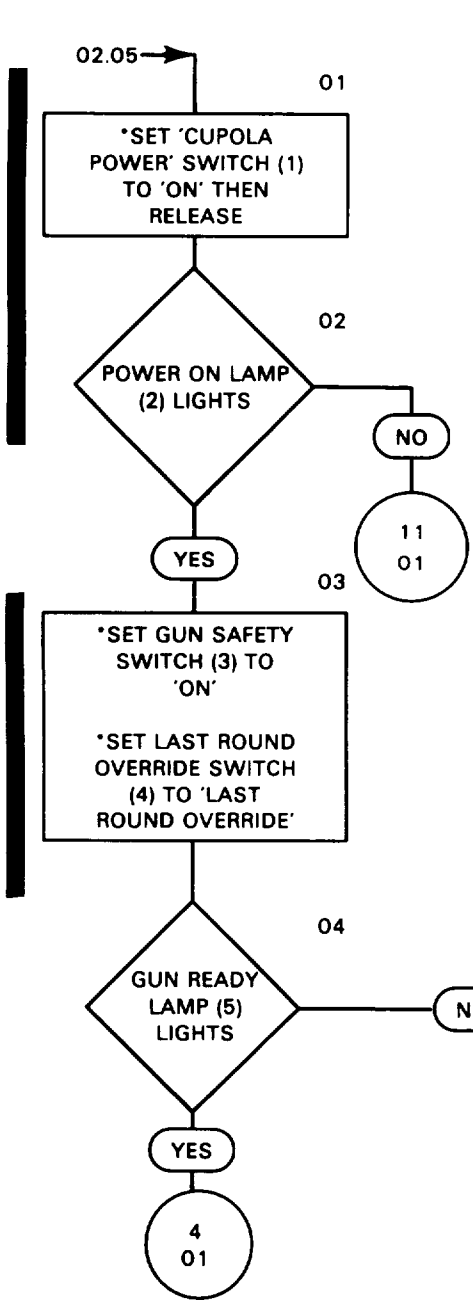

CUPOLA ELECTRICAL POWER CONTROL

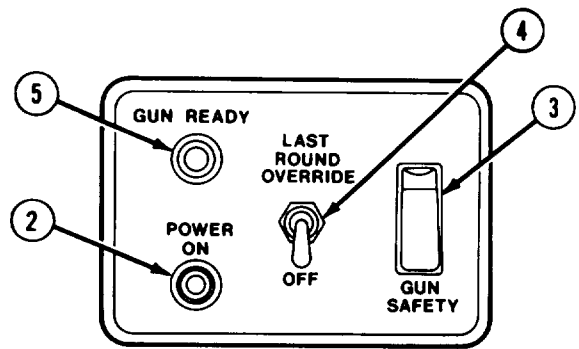

COMMANDER'S PANEL

05
DEFECTIVE COMMANDER'S PANEL
 *REMOVE AND REPLACE COMMANDER'S PANEL (TM-20-2-3, PARA 36-87, 36-88)

3-6. CALIBER .50 MACHINE GUN TROUBLESHOOTING-LAST ROUND STOP INSTALLED
(SHEET 4 OF 29)

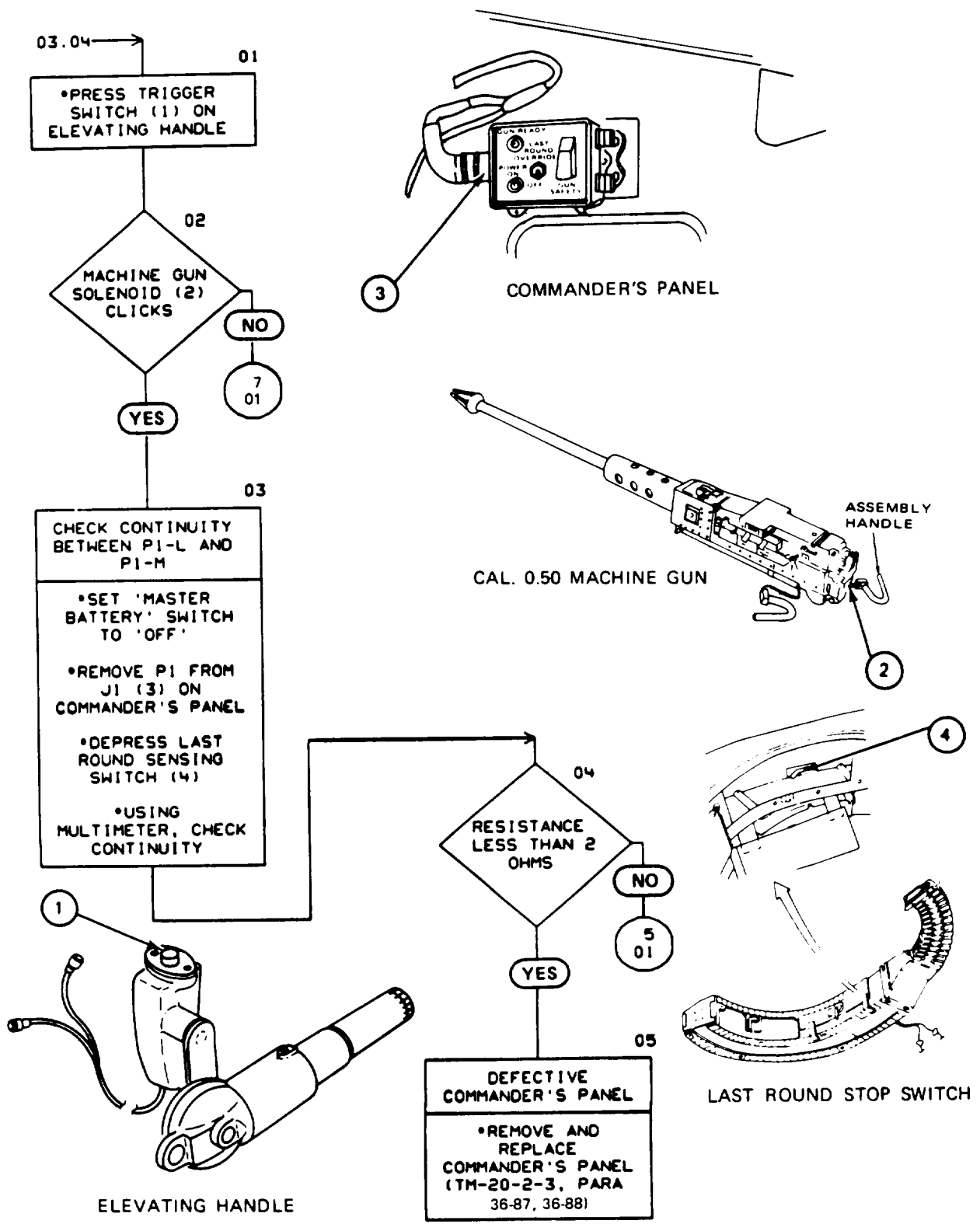

3-6. CALIBER .50 MACHINE GUN TROUBLESHOOTING-LAST ROUND STOP INSTALLED
(SHEET 5 OF 29)

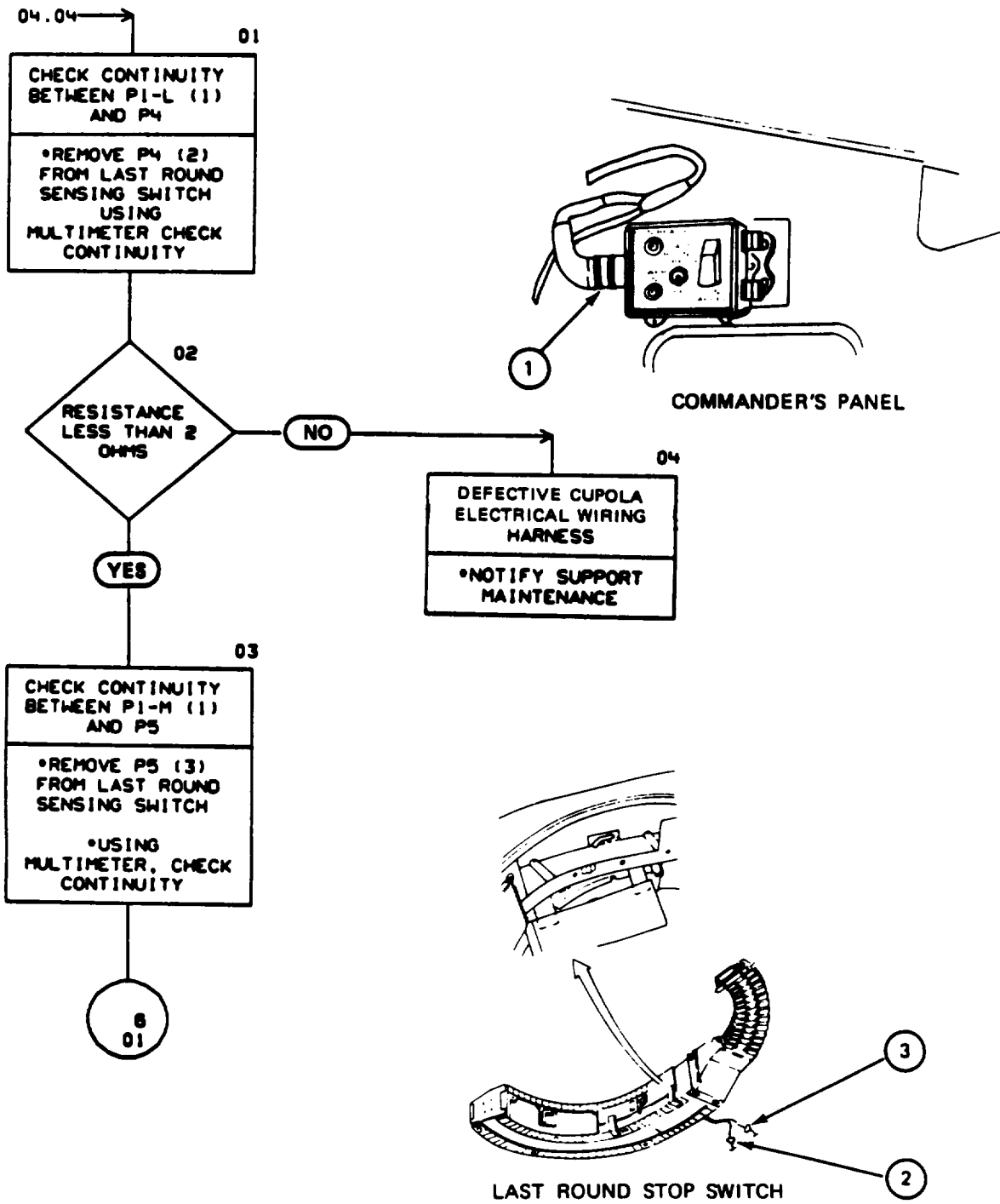

3-6. CALIBER .50 MACHINE GUN TROUBLESHOOTING-LAST ROUND STOP INSTALLED (SHEET 6 OF 29)

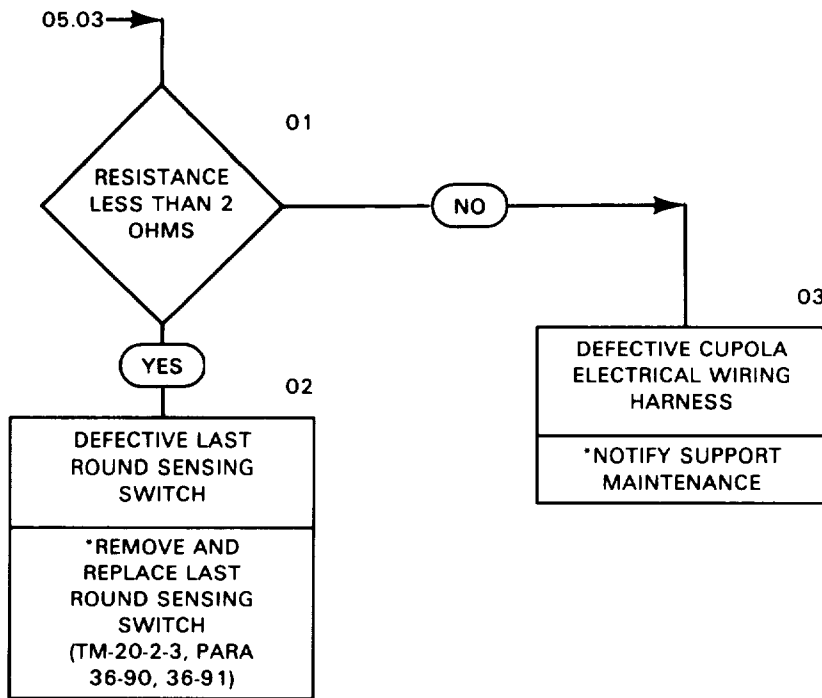

3-6. CALIBER .50 MACHINE GUN TROUBLESHOOTING-LAST ROUND STOP INSTALLED (SHEET 7 OF 29)

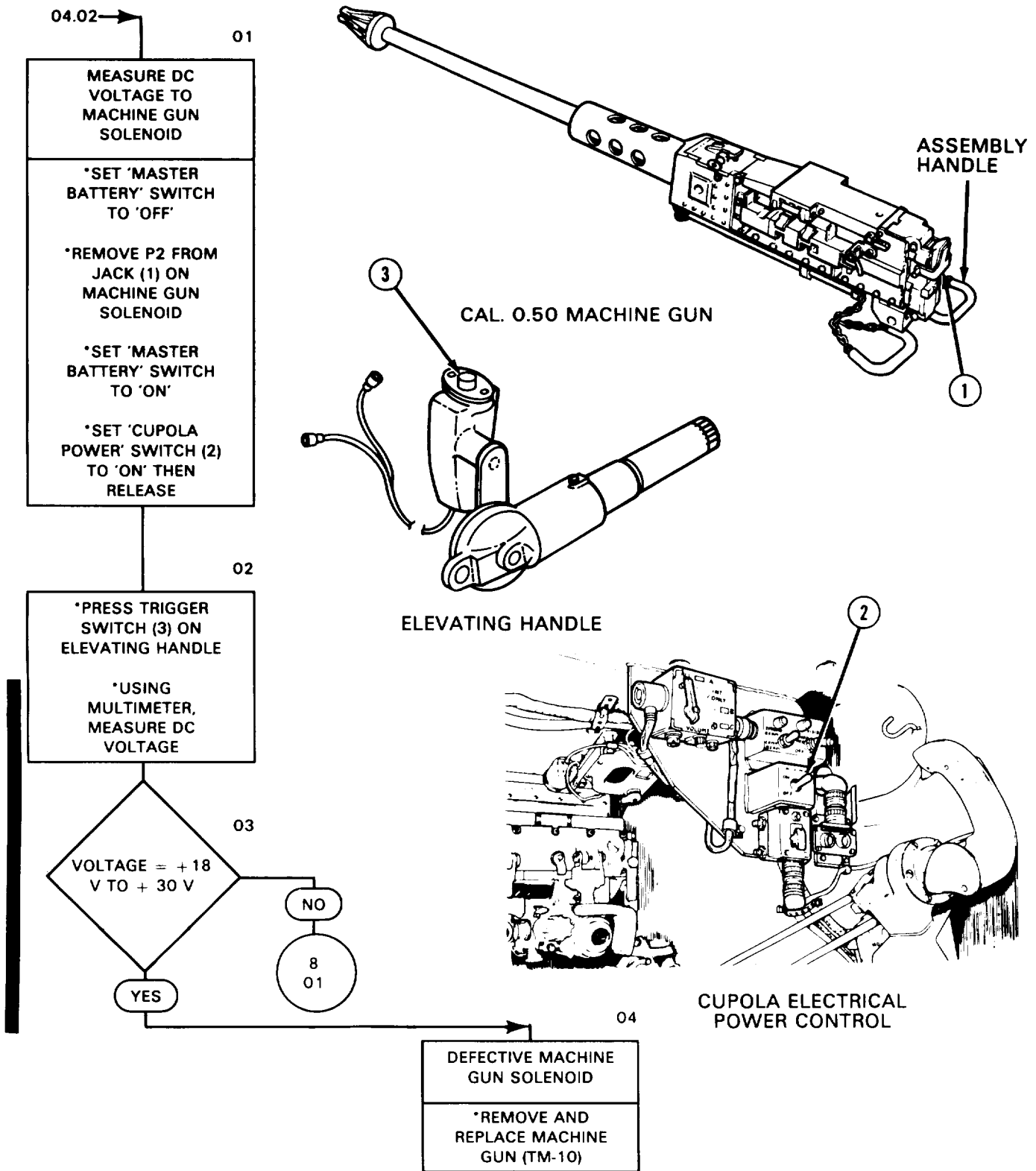

3.6. CALIBER .50 MACHINE GUN TROUBLESHOOTING-LAST ROUND STOP INSTALLED
(SHEET 8 OF 29)

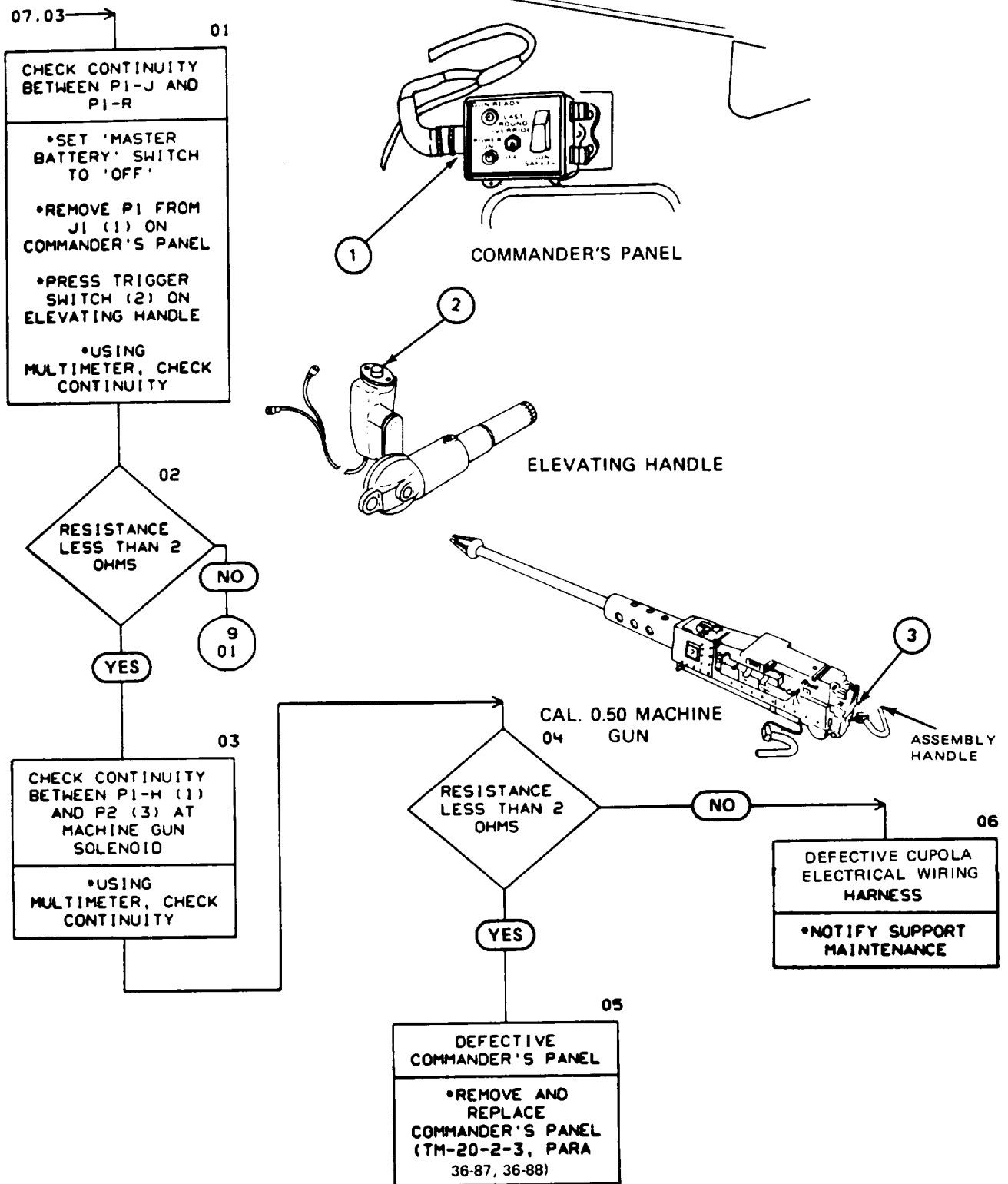

3-6. CALIBER .50 MACHINE GUN TROUBLESHOOTING-LAST ROUND STOP INSTALLED (SHEET 9 OF 29)

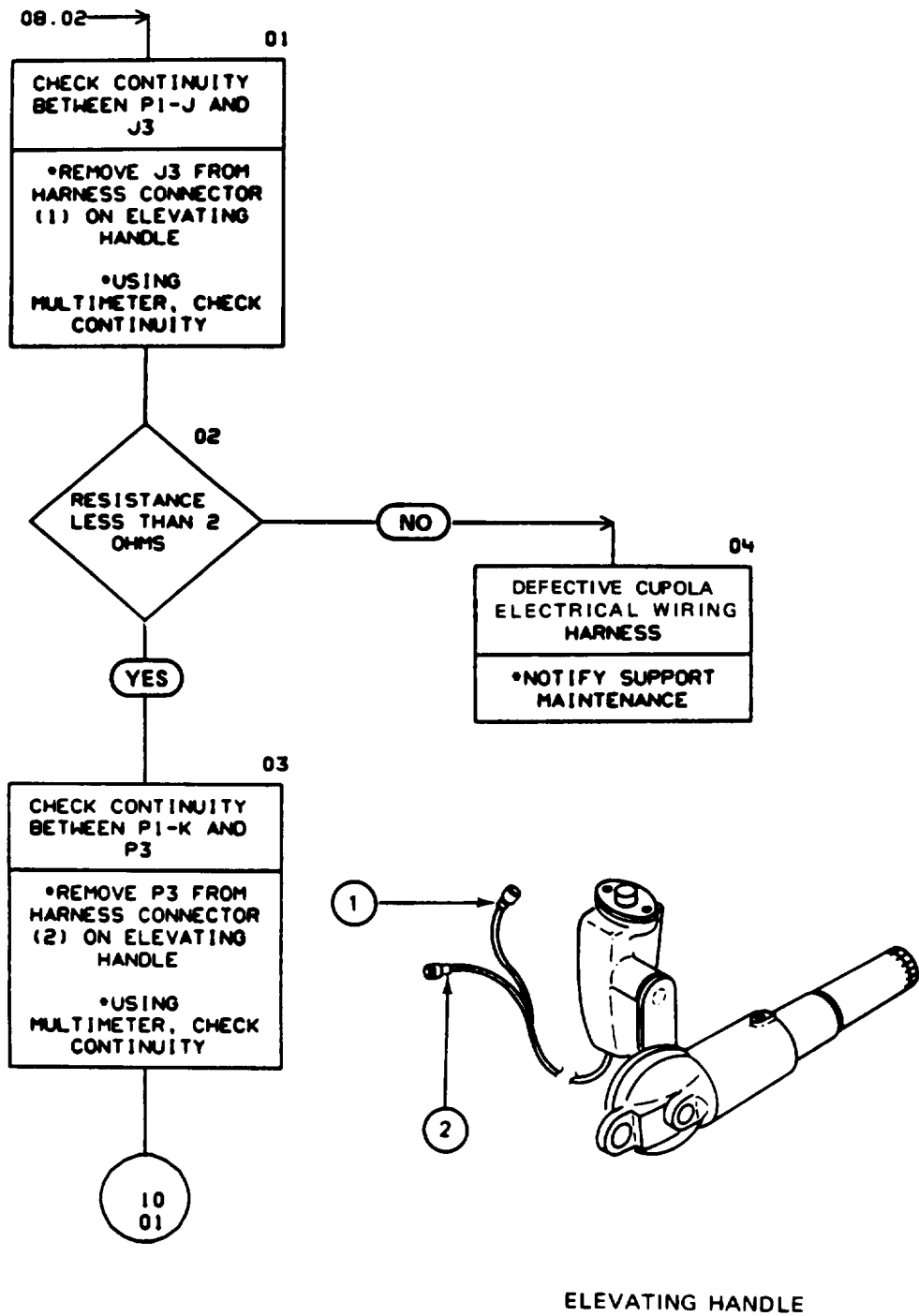

3-6. CALIBER .50 MACHINE GUN TROUBLESHOOTING-LAST ROUND STOP INSTALLED (SHEET 10 OF 29)

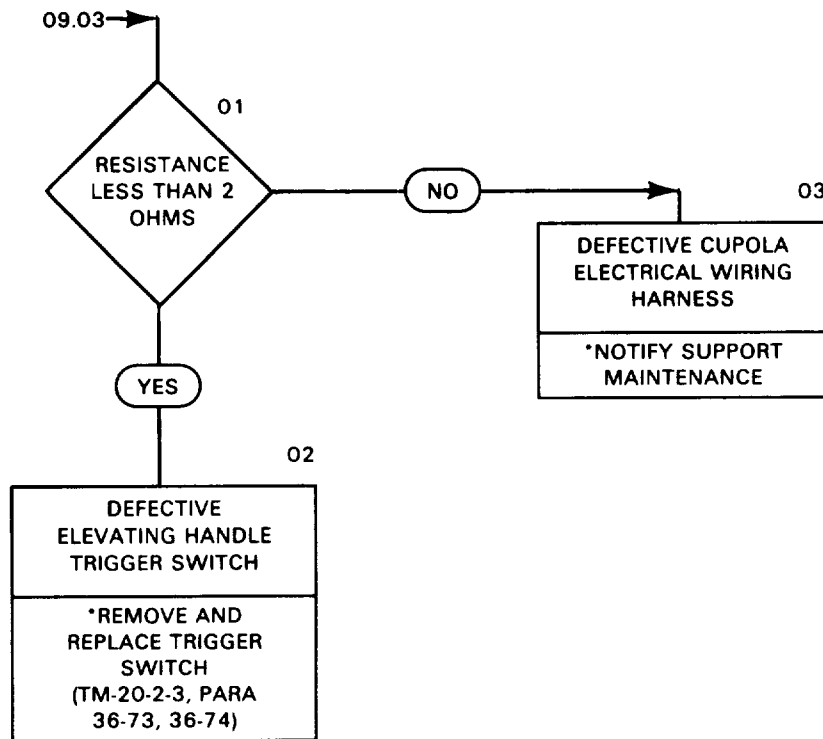

3-6. CALIBER .50 MACHINE GUN TROUBLESHOOTING-LAST ROUND STOP INSTALLED (SHEET 11 OF 29)

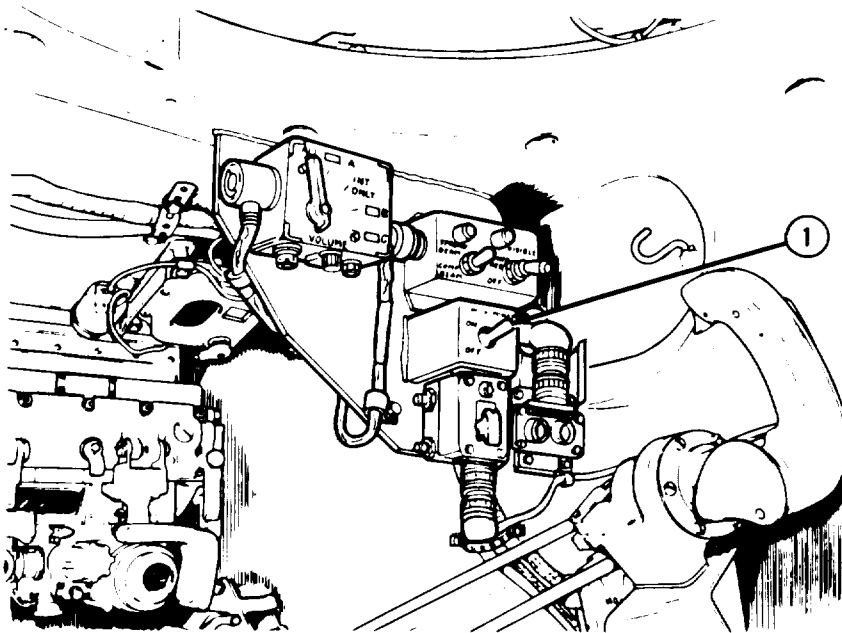
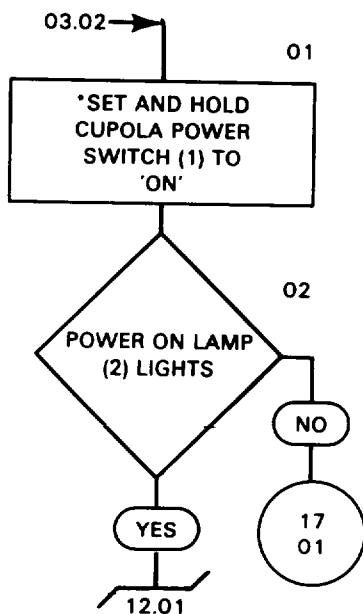

CUPOLA ELECTRICAL POWER CONTROL

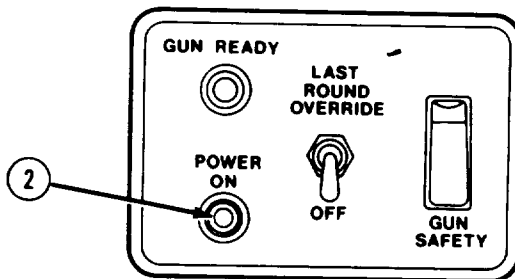

COMMANDER'S PANEL

3-6. CALIBER .50 MACHINE GUN TROUBLESHOOTING-LAST ROUND STOP INSTALLED (SHEET 12 OF 29)

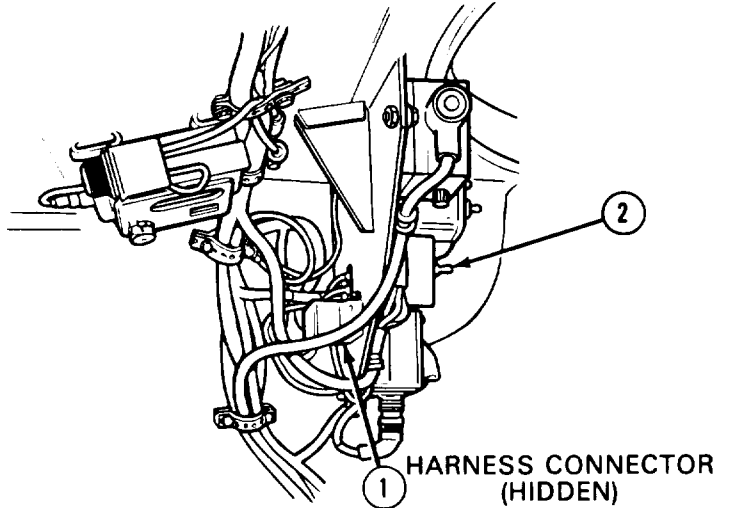
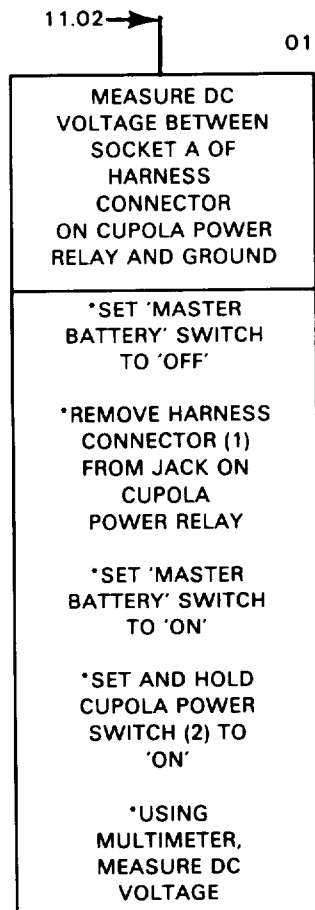

CUPOLA ELECTRICAL POWER CONTROL

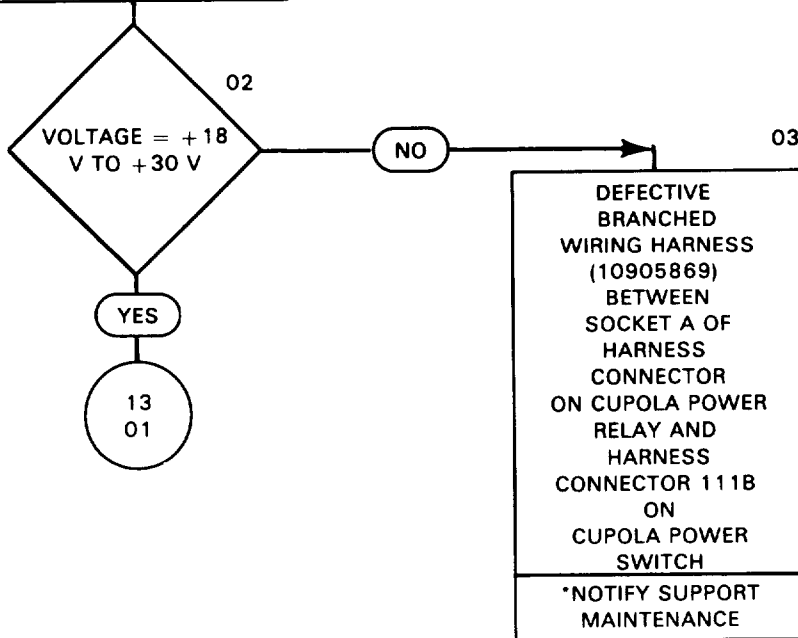

3-6. CALIBER .50 MACHINE GUN TROUBLESHOOTING-LAST ROUND STOP INSTALLED (SHEET 13 OF 29)

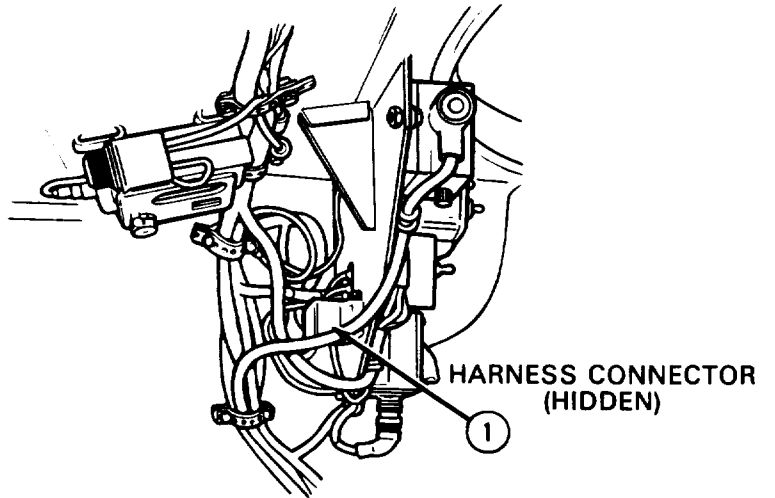
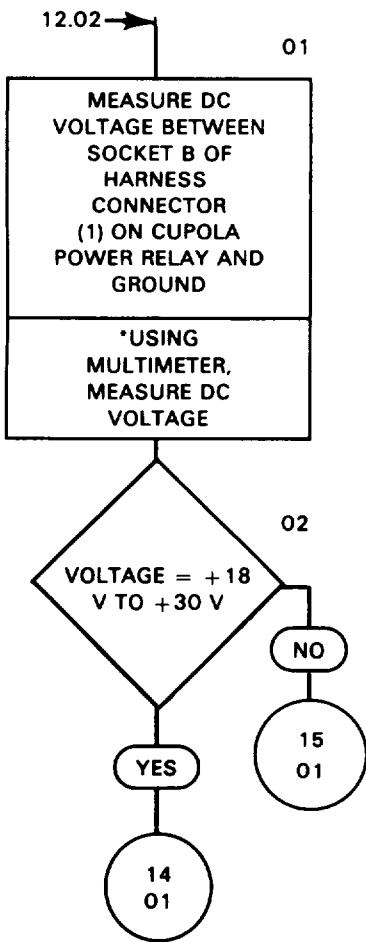

CUPOLA ELECTRICAL POWER CONTROL

3-6. CALIBER .50 MACHINE GUN TROUBLESHOOTING-LAST ROUND STOP INSTALLED (SHEET 14 OF 29)

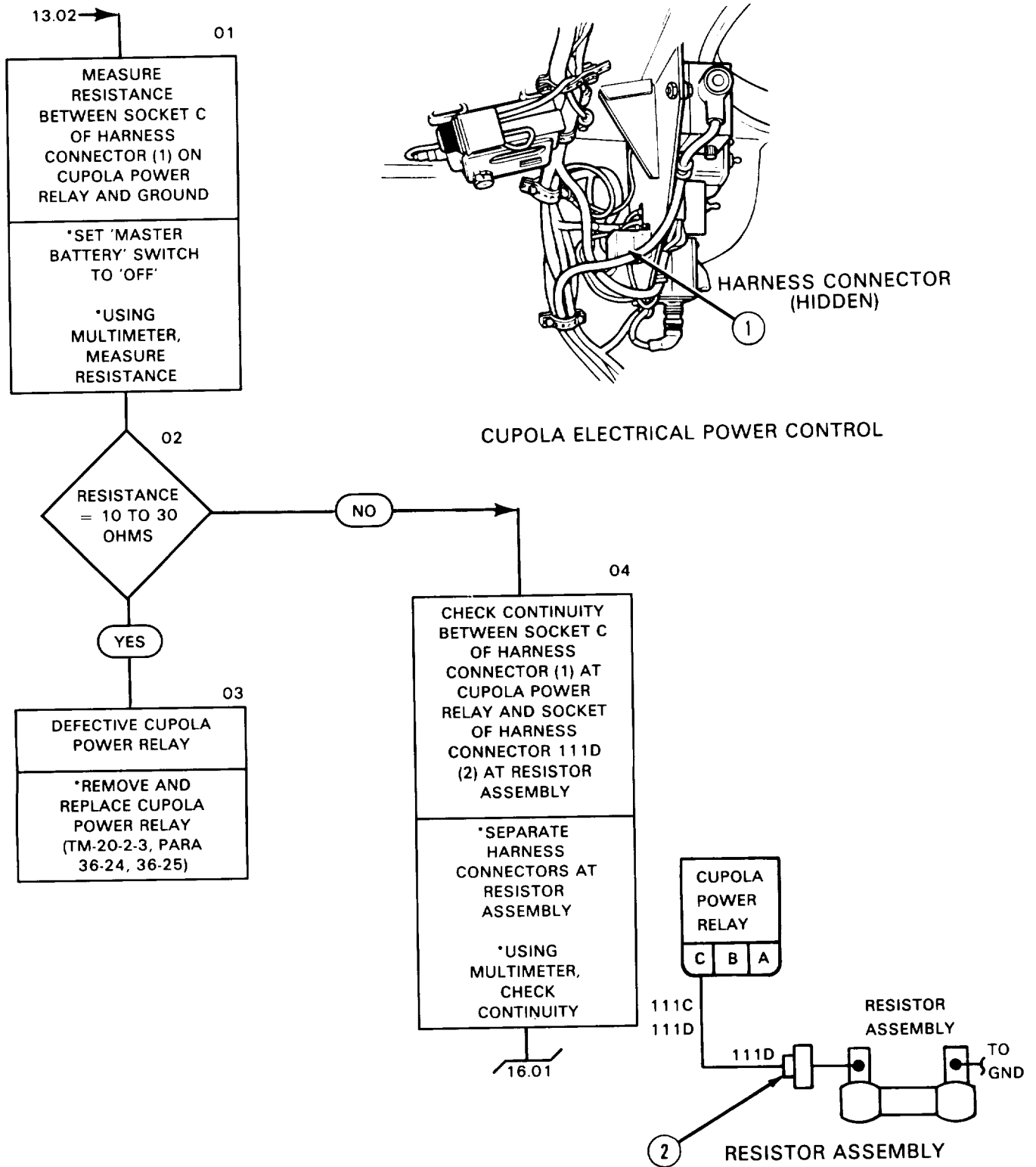

3-6. CALIBER .50 MACHINE GUN TROUBLESHOOTING-LAST ROUND STOP INSTALLED (SHEET 15 OF 29)

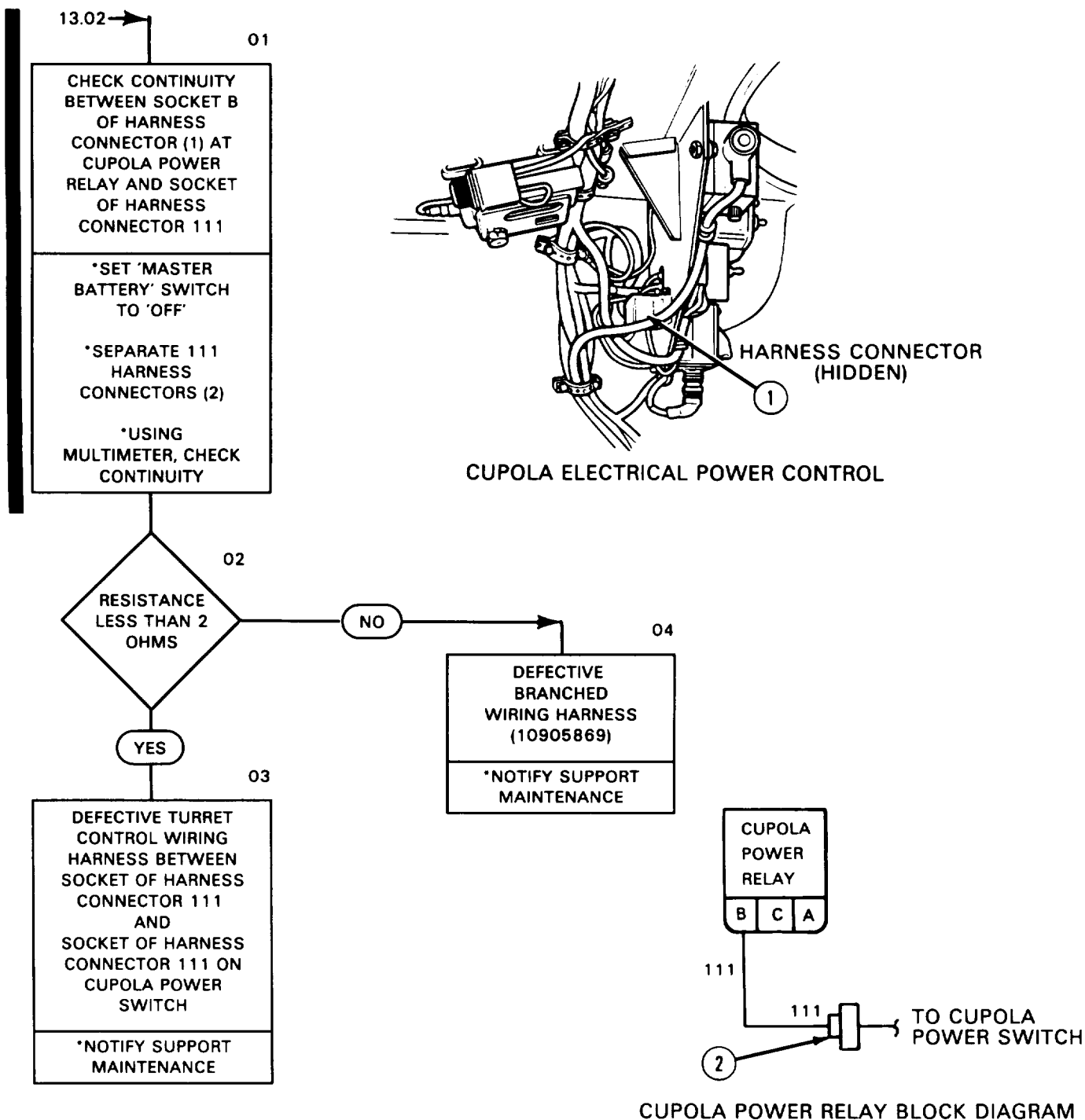

3-6. CALIBER .50 MACHINE GUN TROUBLESHOOTING-LAST ROUND STOP INSTALLED (SHEET 16 OF 29)



3-6. CALIBER .50 MACHINE GUN TROUBLESHOOTING-LAST ROUND STOP INSTALLED (SHEET 17 OF 29)

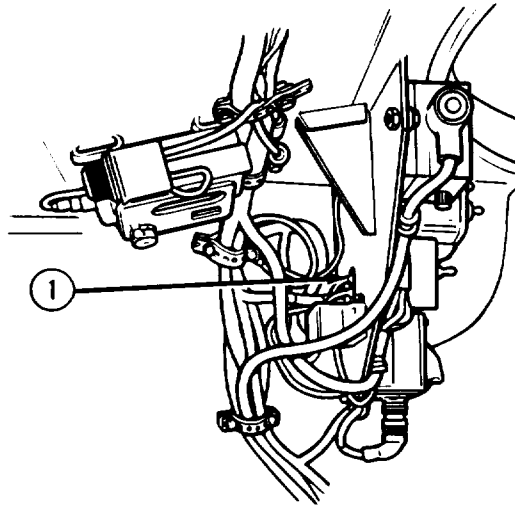
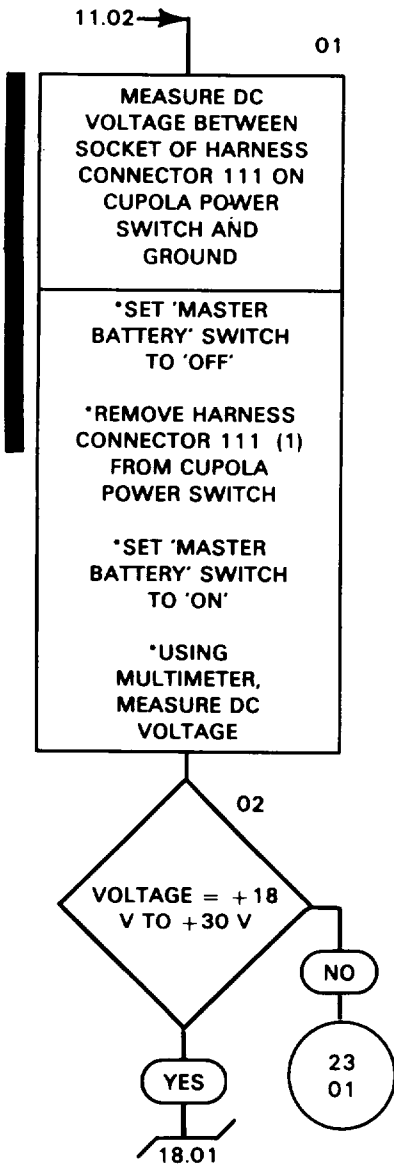

CUPOLA ELECTRICAL POWER CONTROL AND CONNECTORS

3-6. CALIBER .50 MACHINE GUN TROUBLESHOOTING-LAST ROUND STOP INSTALLED (SHEET 18 OF 29)

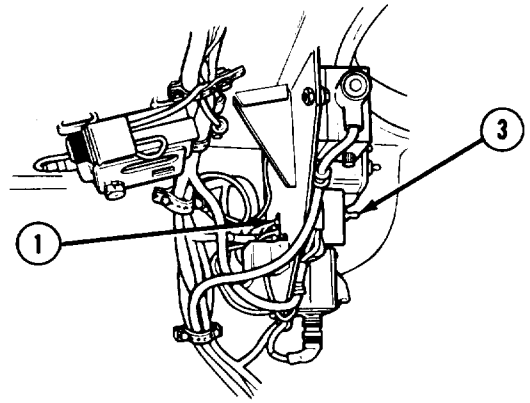
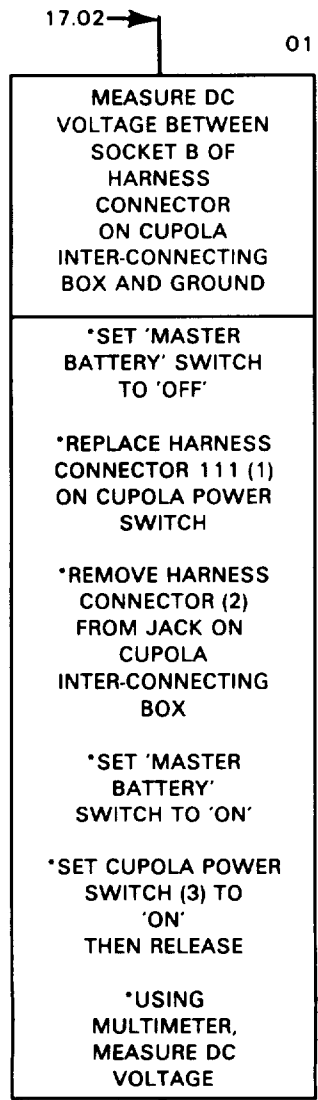

CUPOLA ELECTRICAL POWER CONTROL AND CONNECTORS

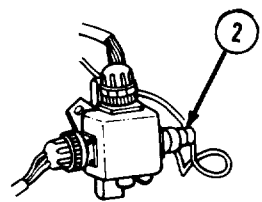

CUPOLA INTERCONNECTING BOX

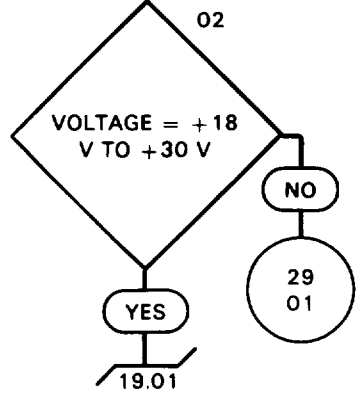

3-6. CALIBER .50 MACHINE GUN TROUBLESHOOTING-LAST ROUND STOP INSTALLED (SHEET 19 OF 29)

18.02
21.03

01

MEASURE DC VOLTAGE BETWEEN P1-A ON COMMANDER'S PANEL AND GROUND

*SET 'MASTER BATTERY' SWITCH TO 'OFF'

*REPLACE HARNESS CONNECTOR (1) ON JACK ON CUPOLA INTERCONNECTING BOX

*REMOVE P1 FROM J1 (2) ON COMMANDER'S PANEL

*SET 'MASTER BATTERY' SWITCH TO 'ON'

*SET 'CUPOLA POWER' SWITCH (3) TO 'ON' THEN RELEASE

*USING MULTIMETER, MEASURE DC VOLTAGE

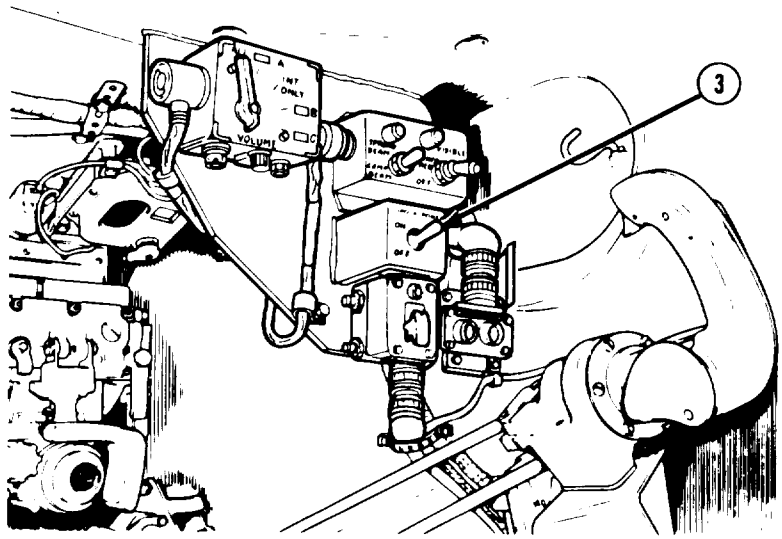

CUPOLA ELECTRICAL POWER CONTROL

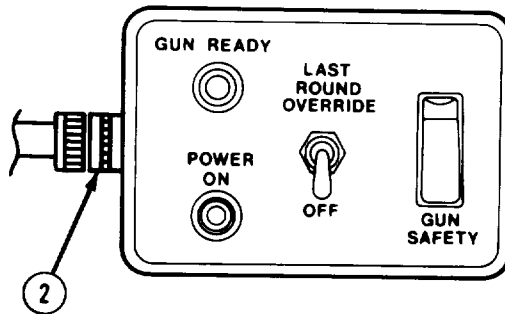

COMMANDER'S PANEL

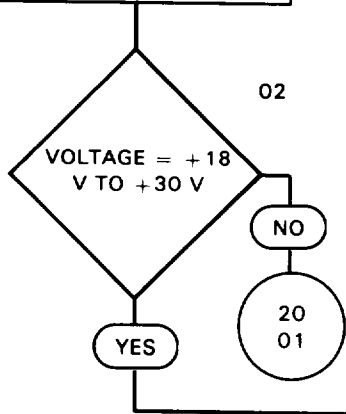

03

DEFECTIVE COMMANDER'S PANEL

REMOVE AND REPLACE COMMANDER'S PANEL (TM -20-2-3, PARA. 38-86, 38-67)

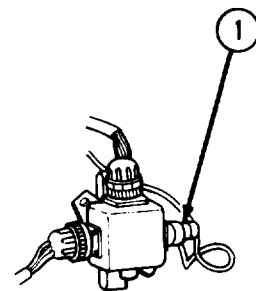

CUPOLA INTERCONNECTING BOX

3-6. CALIBER .50 MACHINE GUN TROUBLESHOOTING-LAST ROUND STOP INSTALLED
(SHEET 20 OF 29)

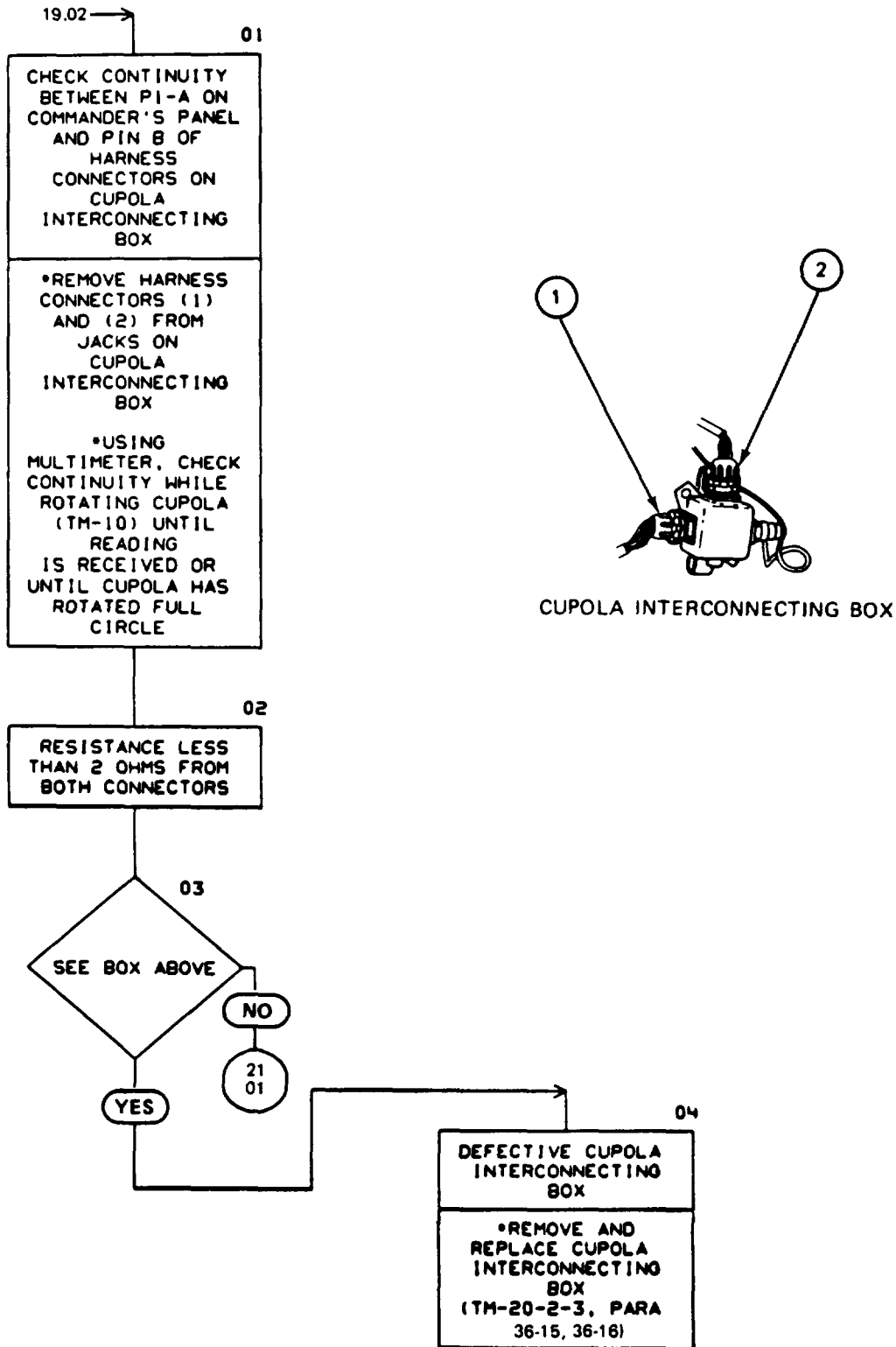

3-6. CALIBER .50 MACHINE GUN TROUBLESHOOTING-LAST ROUND STOP INSTALLED
(SHEET 21 OF 29)

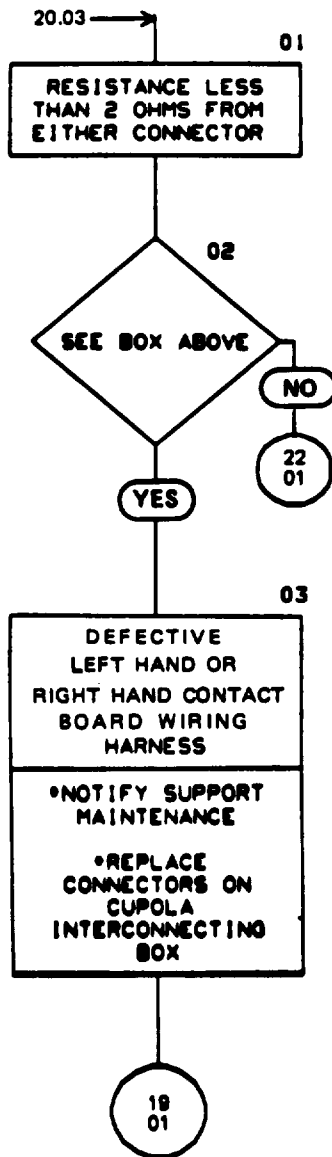

3-6. CALIBER .50 MACHINE GUN TROUBLESHOOTING-LAST ROUND STOP INSTALLED
(SHEET 22 OF 29)

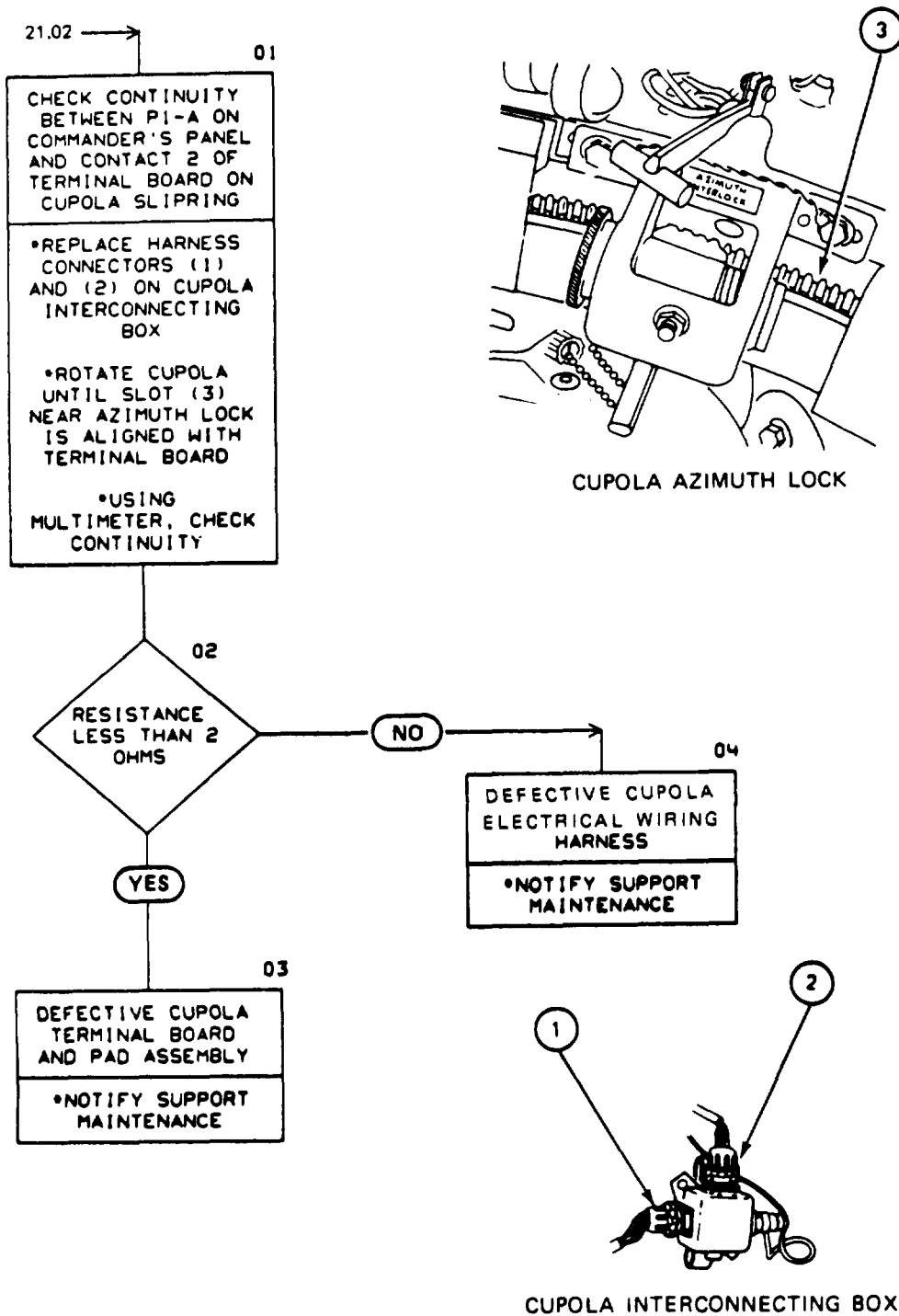

3-6. CALIBER .50 MACHINE GUN TROUBLESHOOTING-LAST ROUND STOP INSTALLED
(SHEET 23 OF 29)

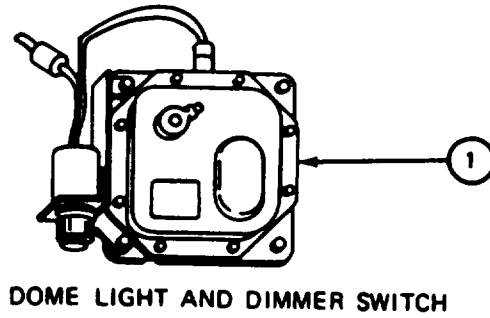
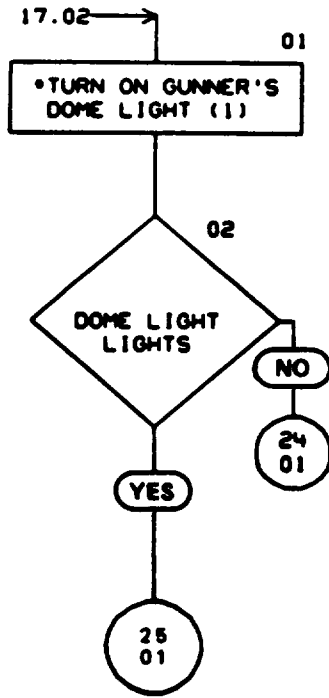

3-6. CALIBER .50 MACHINE GUN TROUBLESHOOTING-LAST ROUND STOP
 INSTALLED (SHEET 24 OF 29)

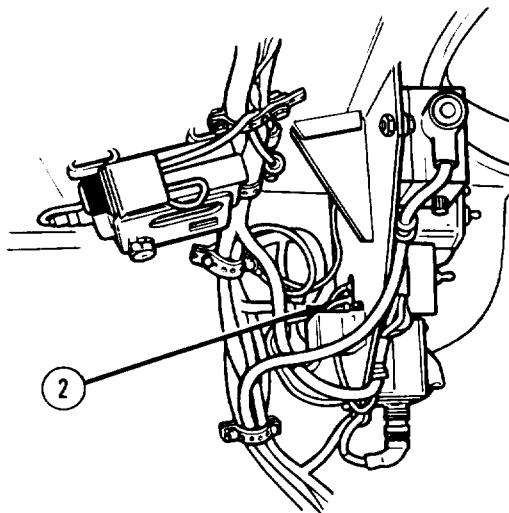
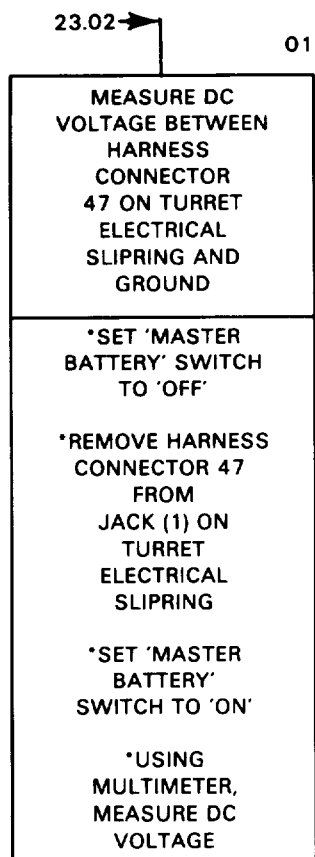

CUPOLA ELECTRICAL POWER CONTROL CONNECTORS

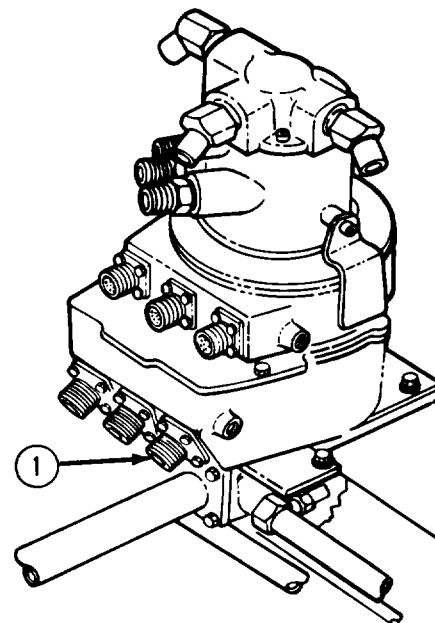
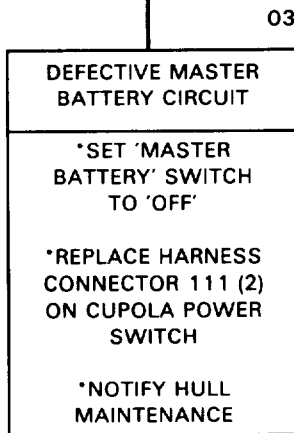
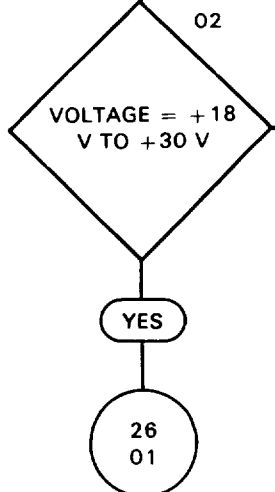

TURRET SLIPRING

3-6. CALIBER .50 MACHINE GUN TROUBLESHOOTING-LAST ROUND STOP INSTALLED (SHEET 25 OF 29)

23.02 →

01

CHECK CONTINUITY BETWEEN HARNESS CONNECTOR 111 (1) AT CUPOLA POWER SWITCH AND SOCKET A, CIRCUIT 111, OF HARNESS CONNECTOR ON TURRET POWER AND SEARCHLIGHT RELAY BOX

*SET 'MASTER BATTERY' SWITCH TO 'OFF'

*REMOVE HARNESS CONNECTOR FROM JACK (2) ON TURRET POWER AND SEARCHLIGHT RELAY BOX

*USING MULTIMETER, CHECK CONTINUITY

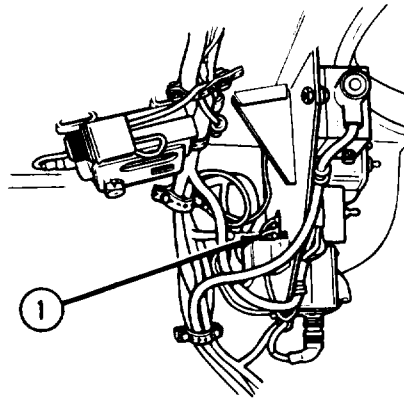

CUPOLA ELECTRICAL POWER CONTROL AND CONNECTORS

25.03 →

NOTE 05

CONTINUED FROM A PRIOR COLUMN

*REPLACE HARNESS CONNECTOR 111 (1) ON JACK ON CUPOLA POWER SWITCH

*REMOVE AND REPLACE TURRET POWER AND SEARCHLIGHT RELAY BOX (TM-20-2-3, PARA 9-2, 9-3)

02

RESISTANCE LESS THAN 2 OHMS

NO

04

DEFECTIVE TURRET CONTROL WIRING HARNESS

*NOTIFY SUPPORT MAINTENANCE

YES

03

DEFECTIVE TURRET POWER AND SEARCHLIGHT RELAY BOX

25.05

2

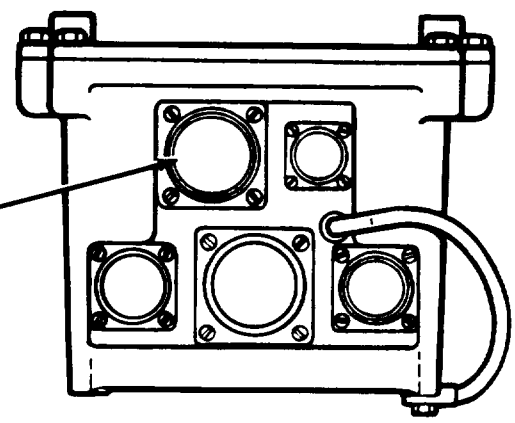

AND SEARCHLIGHT RELAY BOX

3-6. CALIBER .50 MACHINE GUN TROUBLESHOOTING-LAST ROUND STOP INSTALLED (SHEET 26 OF 29)

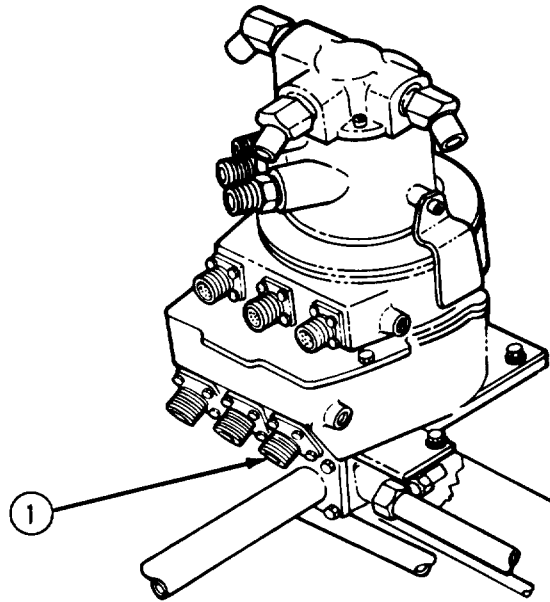
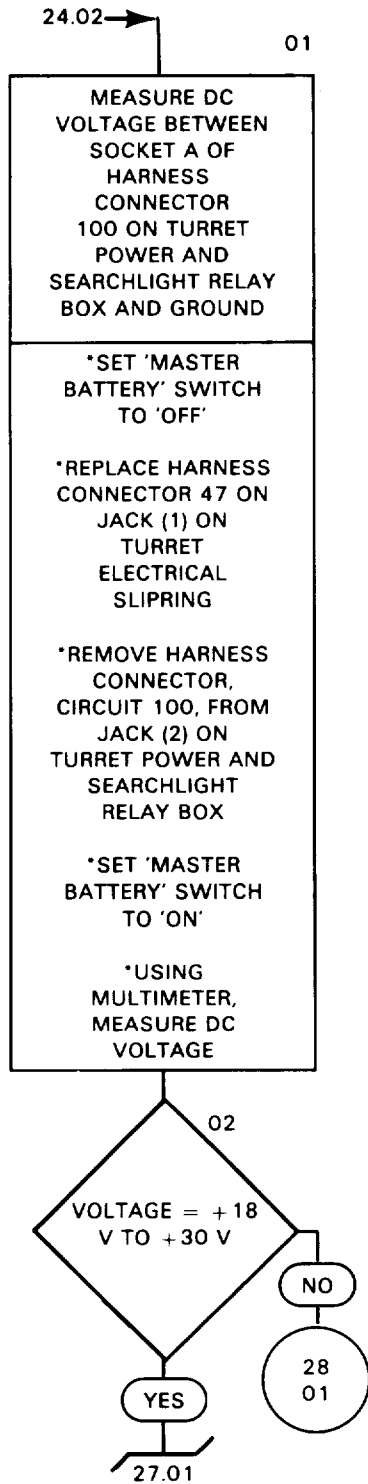

TURRET SLIPRING

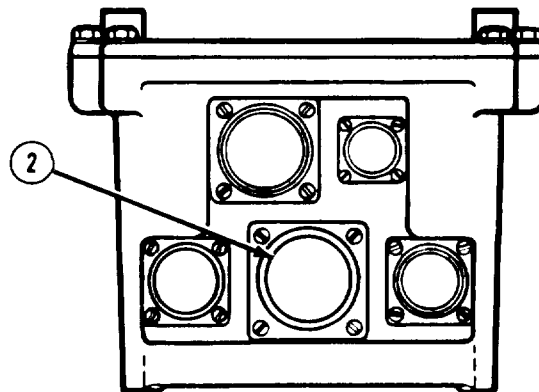

TURRET POWER AND SEARCHLIGHT RELAY BOX

3-6. CALIBER .50 MACHINE GUN TROUBLESHOOTING-LAST ROUND STOP INSTALLED (SHEET 27 OF 29)

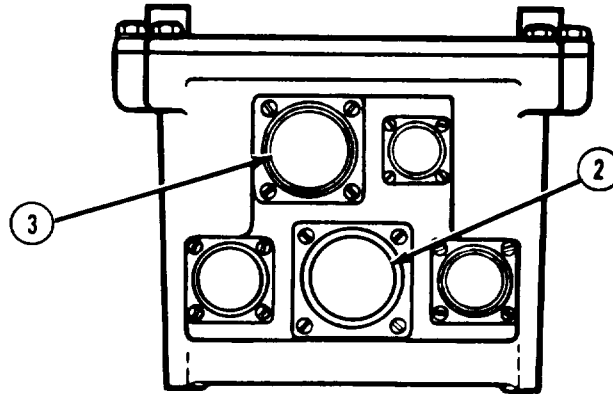
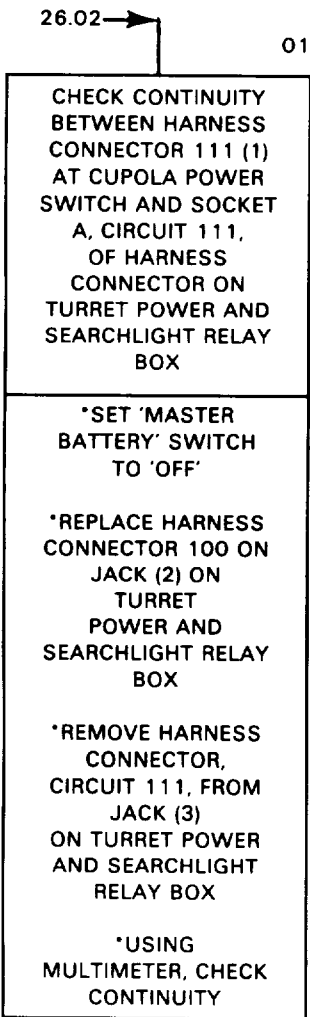

TURRET POWER AND SEARCHLIGHT RELAY BOX

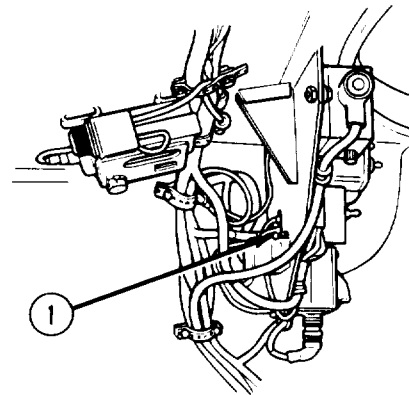
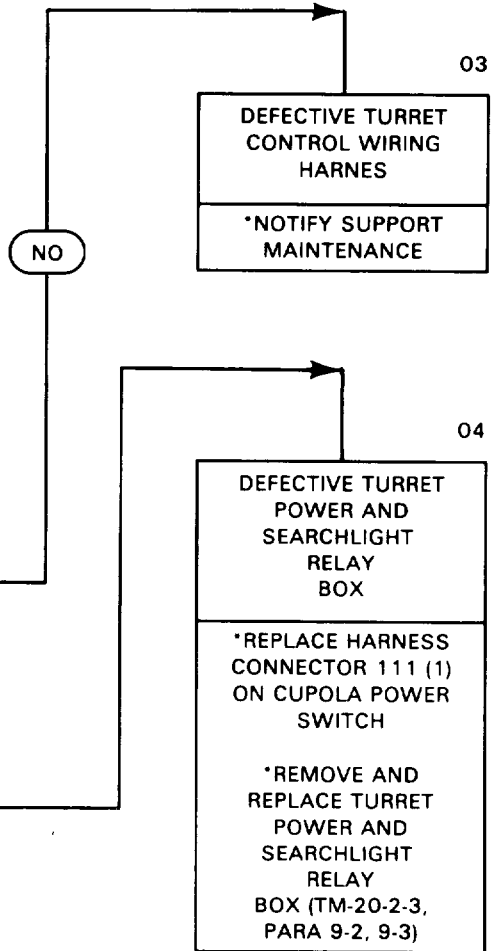

CUPOLA ELECTRICAL POWER CONTROL AND CONNECTORS

3-6. CALIBER .50 MACHINE GUN TROUBLESHOOTING-LAST ROUND STOP INSTALLED (SHEET 28 OF 29)

26.02 →

01

CHECK CONTINUITY BETWEEN HARNESS CONNECTOR 100 (1) TURRET ELECTRICAL SLIPRING AND SOCKET A OF HARNESS CONNECTOR 100 ON JACK (1) ON TURRET POWER AND SEARCHLIGHT RELAY BOX

*SET 'MASTER BATTERY' SWITCH TO 'OFF'

*REMOVE HARNESS CONNECTOR 100 FROM JACK (2) ON TURRET ELECTRICAL SLIPRING

*USING MULTIMETER, CHECK CONTINUITY

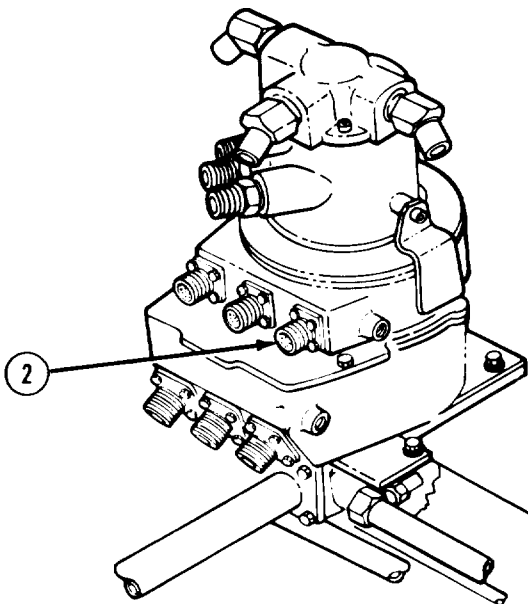

TURRET SLIPRING

28.03 →

NOTE 05

CONTINUED FROM A PRIOR COLUMN

AND SEARCHLIGHT RELAY BOX

*REMOVE AND REPLACE TURRET ELECTRICAL SLIPRING (TM-20-2-3, PARA 3-7, 3-8)



YES

NO

03

DEFECTIVE TURRET ELECTRICAL SLIPRING

*REPLACE HARNESS CONNECTOR 100 ON JACK (1) ON TURRET POWER

04

DEFECTIVE SLIPRING TO TURRET POWER RELAY BOX WIRING HARNES

*NOTIFY SUPPORT MAINTENANCE

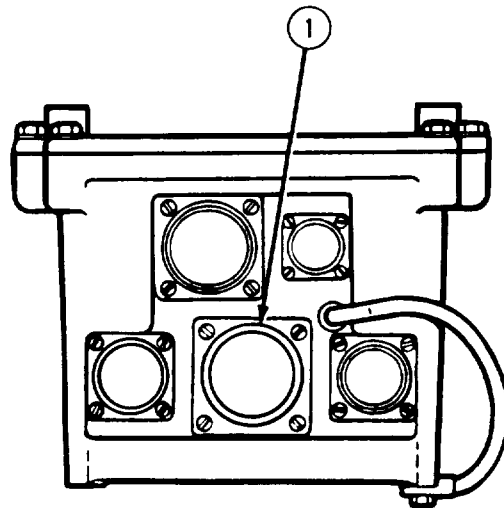

TURRET POWER AND SEARCHLIGHT RELAY BOX

28.05

3-6. CALIBER .50 MACHINE GUN TROUBLESHOOTING-LAST ROUND STOP INSTALLED (SHEET 29 OF 29)

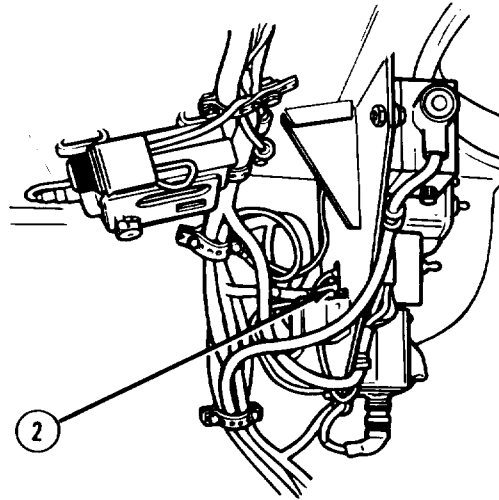
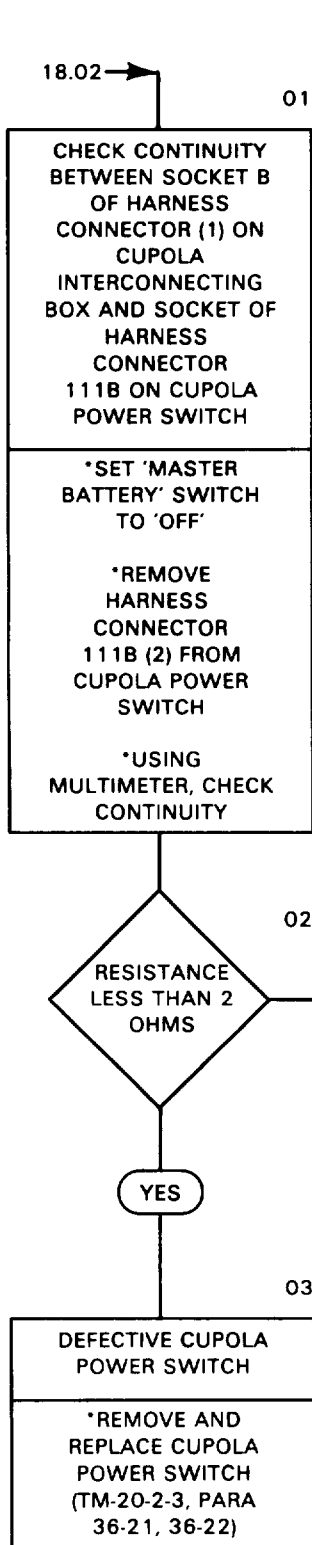

CUPOLA ELECTRICAL POWER CONTROL AND CONNECTORS

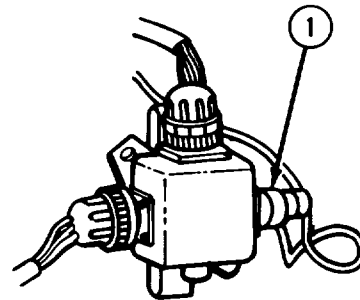

CUPOLA INTERCONNECTING BOX

CHAPTER 4

TURRET TRAVERSE AND GUN ELEVATION FAULT ISOLATION DIAGRAMS

4-1. TURRET TRAVERSE TROUBLESHOOTING (SHEET 1 OF 75)

- SYMPTOM: (15) Electric Drive (DC) Motor fails to run
 (16) Electric Drive (DC) Motor makes excessive noise
 (17) Electric Drive (DC) Motor runs continuously
 (18) Incorrect accumulator gage pressure
 (19) Turret fails to traverse smoothly with Manual Traverse Handle
 (20) Turret fails to traverse with Gunner's Handle
 (21) Turret fails to traverse with Commander's Handle
 (22) Turret creeps or traverses without palm switch pressed
 (23) Turret oscillates or drives erratically

TEST EQUIPMENT: Multimeter

PERSONNEL: Two

UNIT LOCATION:	FOLDOUT	CALLOUT
Master Control Panel	4	4
Gunner's Control Box	1	2
Gunner's Control Handle	1	19
Commander's Control Handle	2	12
Turret Power and Searchlight Relay Box	1	9
Pressure Switch	1	11
Turret Traverse Mechanism	2	11
Hand Traverse Drive	1	3
Pressure Gage	1	18
Hydraulic Power Pack	1	10

- REFERENCES: (1) TM 9-2350-222-20-2-3 for removal and replacement of components
 (2) ETM 643-091-9400-R/JPG for procedures to:
 Use multimeter
 Disconnect electrical connectors
 (3) TM 9-2350-222-10 for procedure to:
 Lock and release turret traversing lock

EQUIPMENT CONDITION: Vehicle parked, power off.

4-1. TURRET TRAVERSE TROUBLESHOOTING (SHEET 2 OF 75)

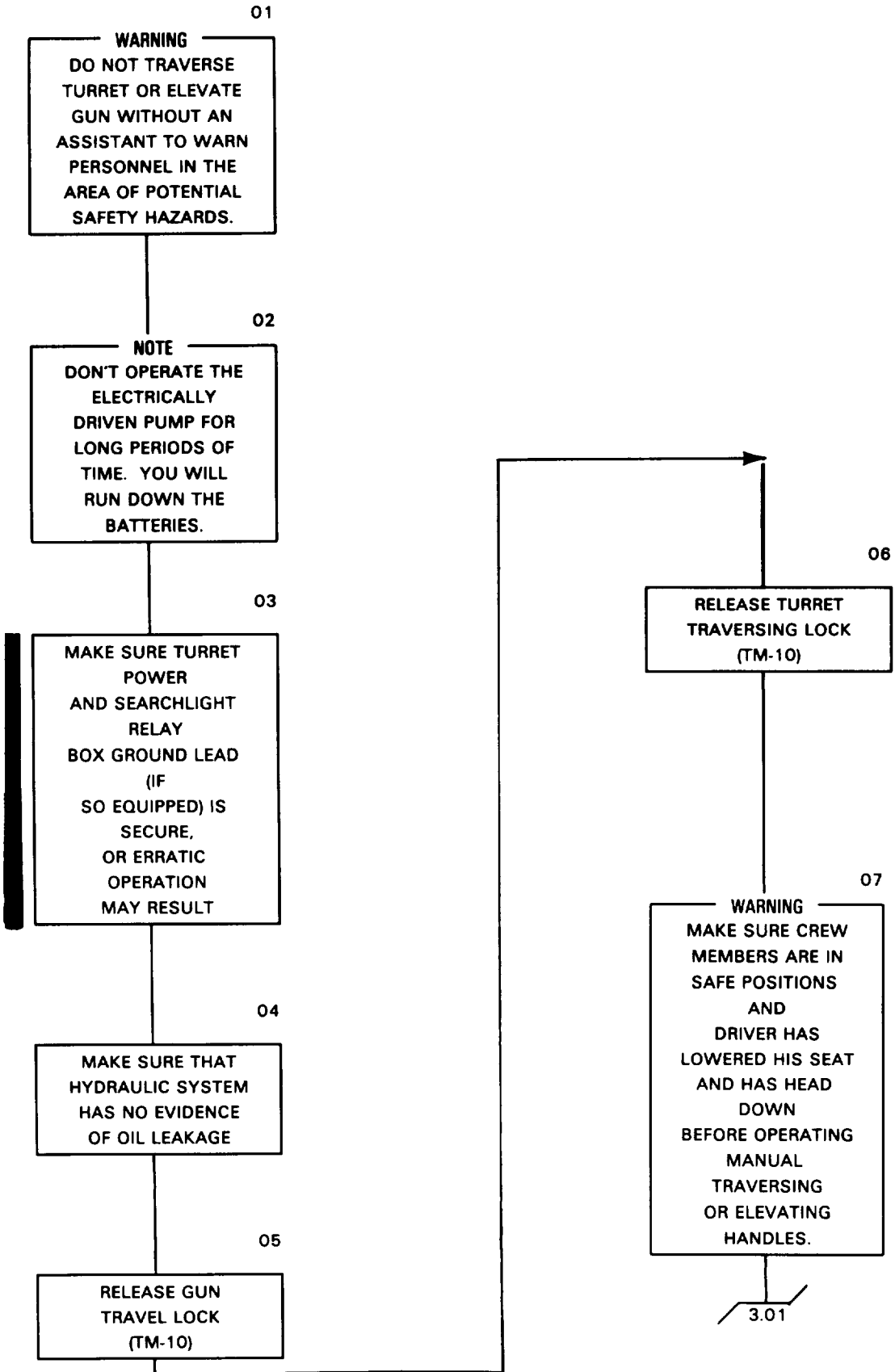

4.1. TURRET TRAVERSE TROUBLESHOOTING (SHEET 3 OF 75)

02.06 → 01

CAUTION

DEFLATE HULL
TURRET SEAL TO 0
PSI
(TM-10)

MAKE SURE THAT
THE TURRET RING
GEAR (1) HAS NO
FOREIGN MATERIAL
ON IT

MAKE SURE THAT
THE OUTPUT
PINIONS (2) OF
TRAVERSE
GEAR BOX HAVE NO
FOREIGN MATERIAL
ON THEM

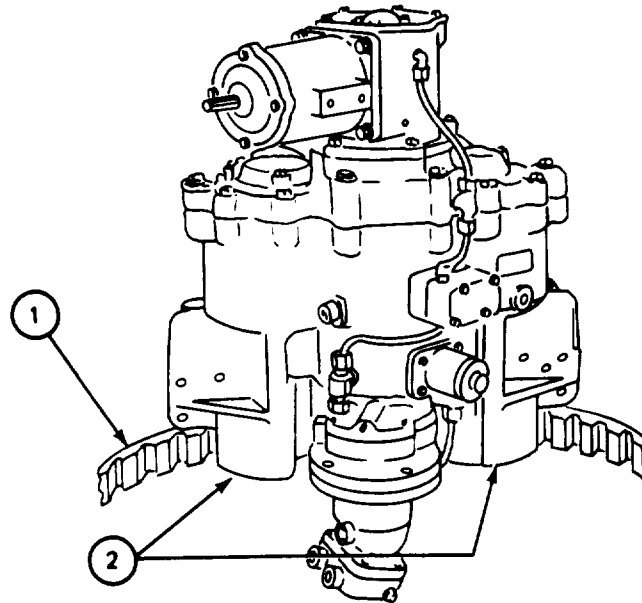

TRAVERSE MECHANISM ASSEMBLY

02

MANUALLY TRAVERSE
GUN TO FORWARD
POSITION WITH
TRAVERSE HANDLE

• SQUEEZE LOCKING
LEVER ACTUATOR
AND ROTATE HANDLE
(3)

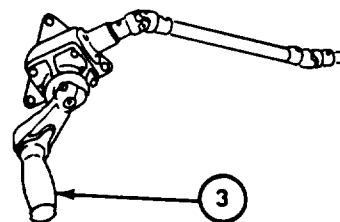
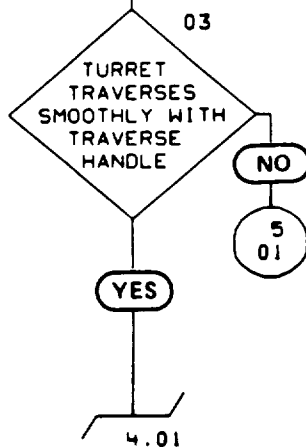

HAND TRAVERSING
DRIVE ASSEMBLY

4-1. TURRET TRAVERSE TROUBLESHOOTING (SHEET 4 OF 75)

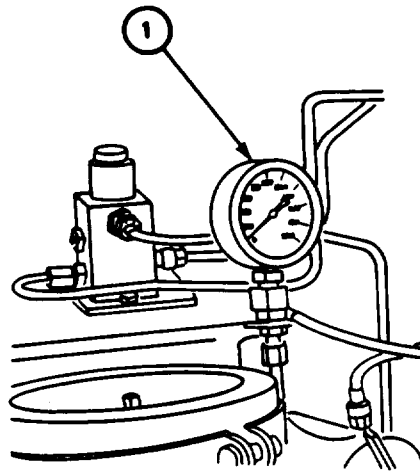
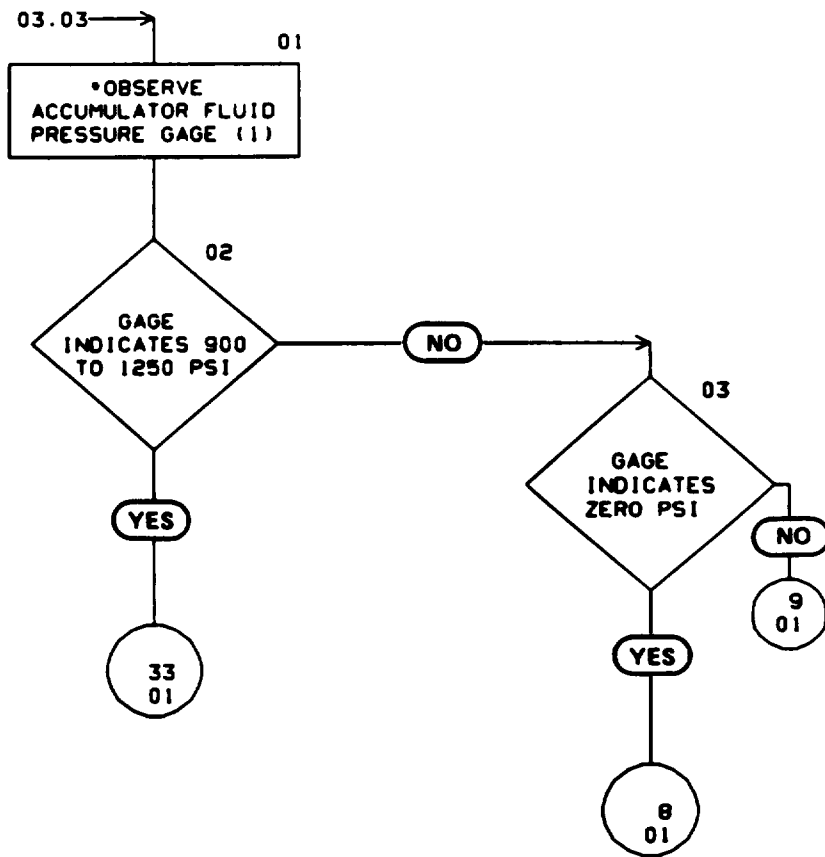

PRESSURE GAGE

4-1. TURRET TRAVERSE TROUBLESHOOTING (SHEET 5 OF 75)

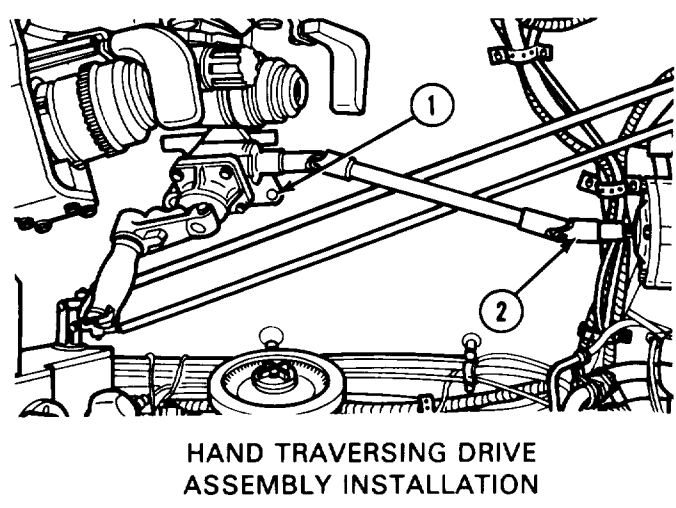
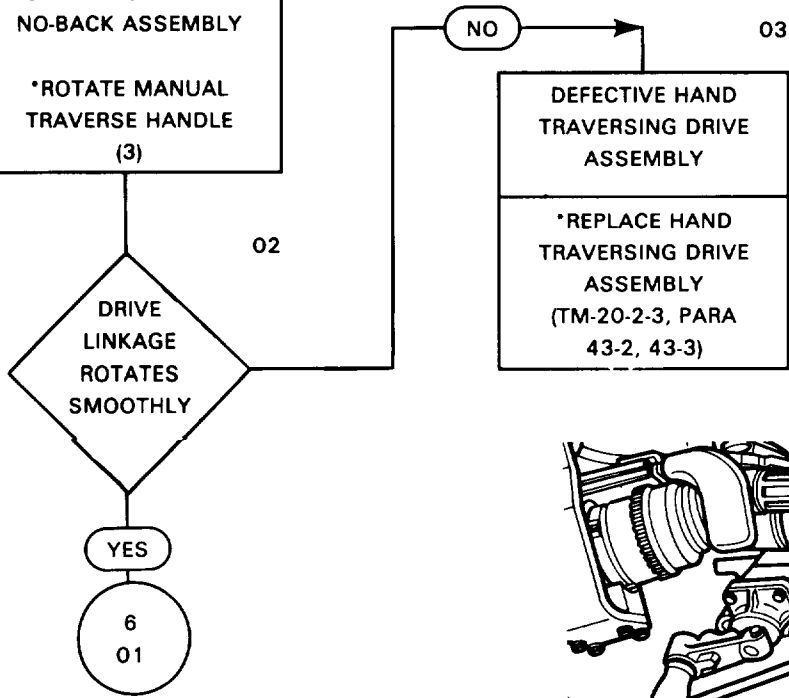
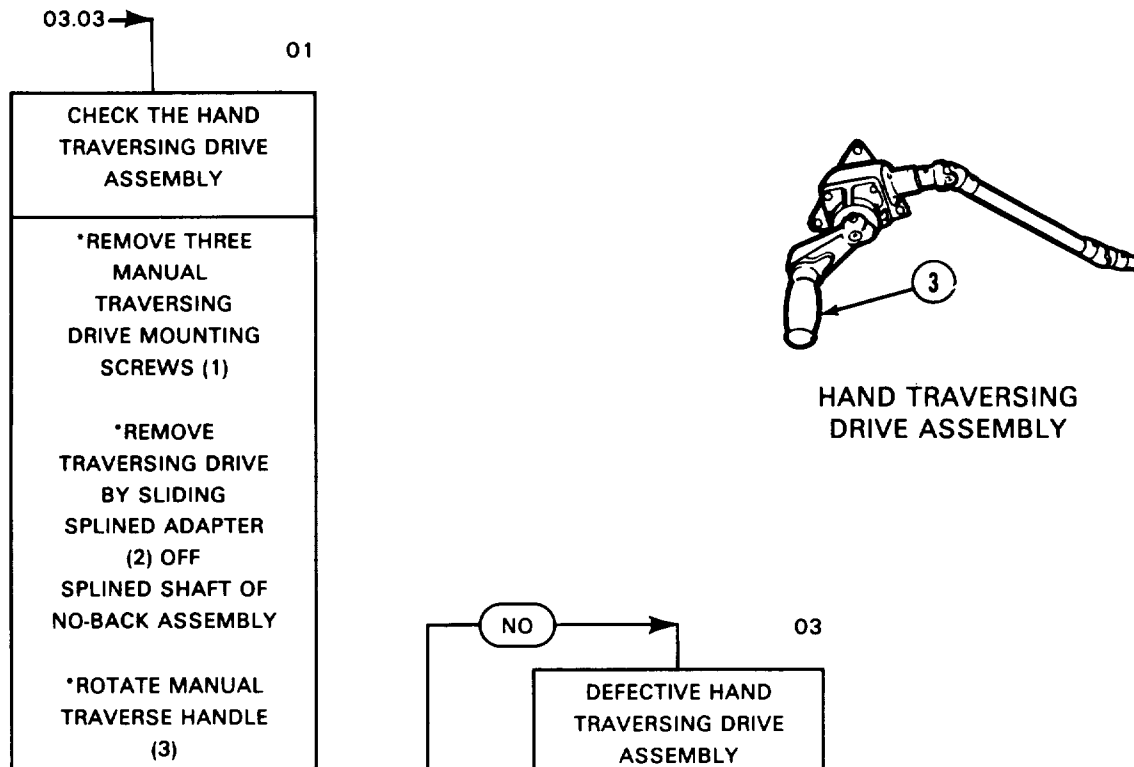

4-1. TURRET TRAVERSE TROUBLESHOOTING (SHEET 6 OF 75)

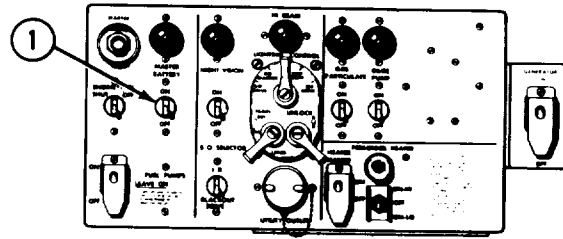
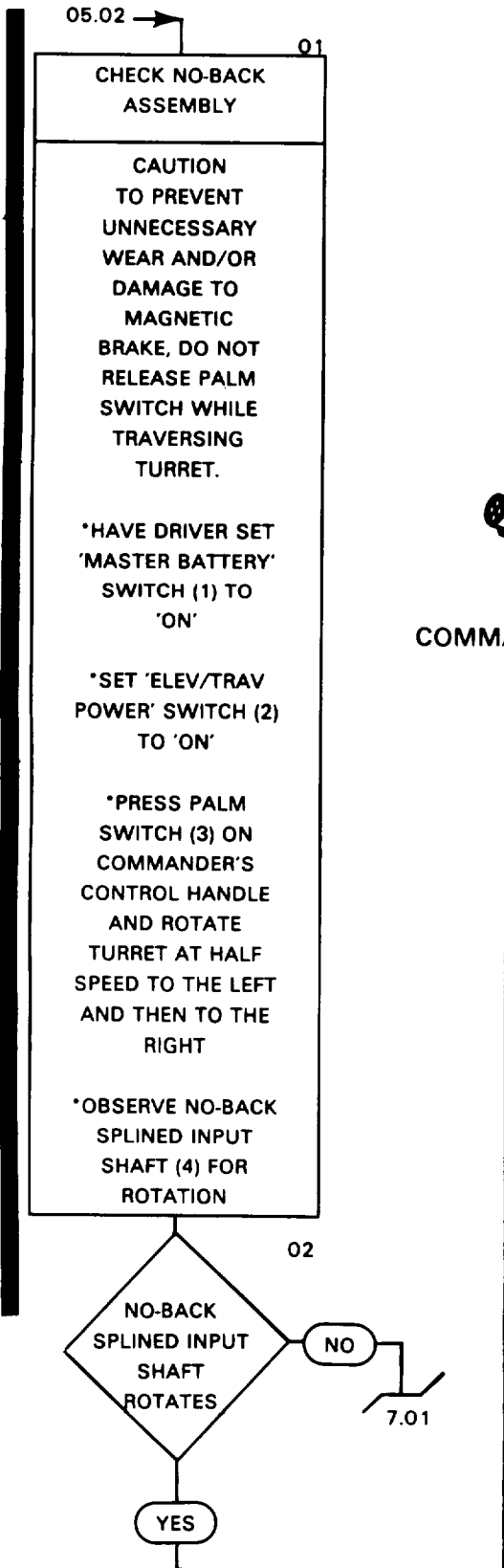

MASTER CONTROL PANEL

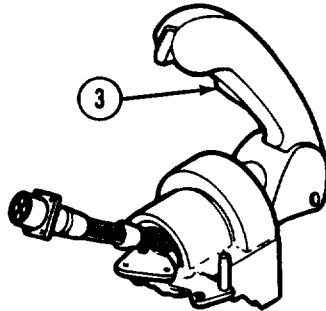

COMMANDER'S CONTROL HANDLE

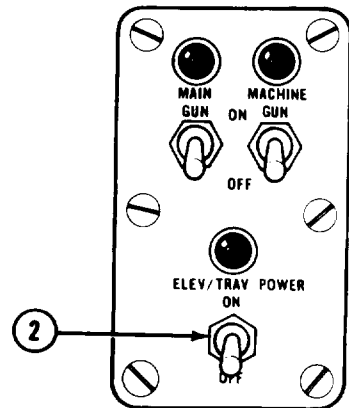

GUNNER'S CONTROL BOX

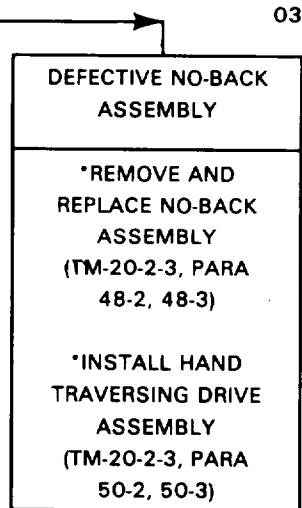
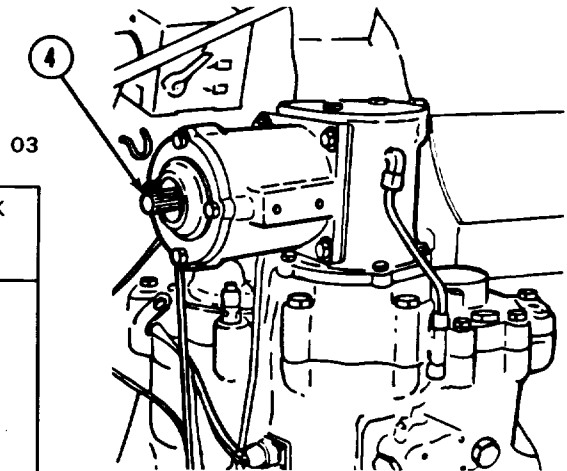

4-1. TURRET TRAVERSE TROUBLESHOOTING (SHEET 7 OF 75)

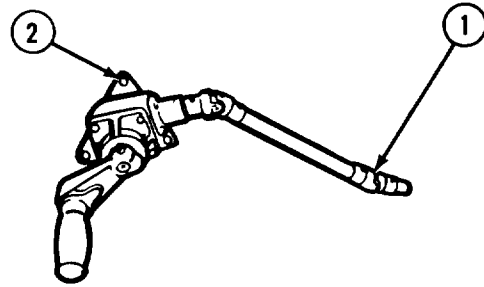
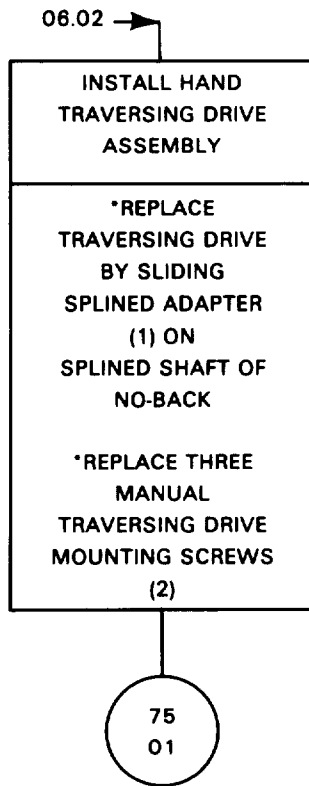

HAND TRAVERSING ASSEMBLY

4-1. TURRET TRAVERSE TROUBLESHOOTING (SHEET 8 OF 75)

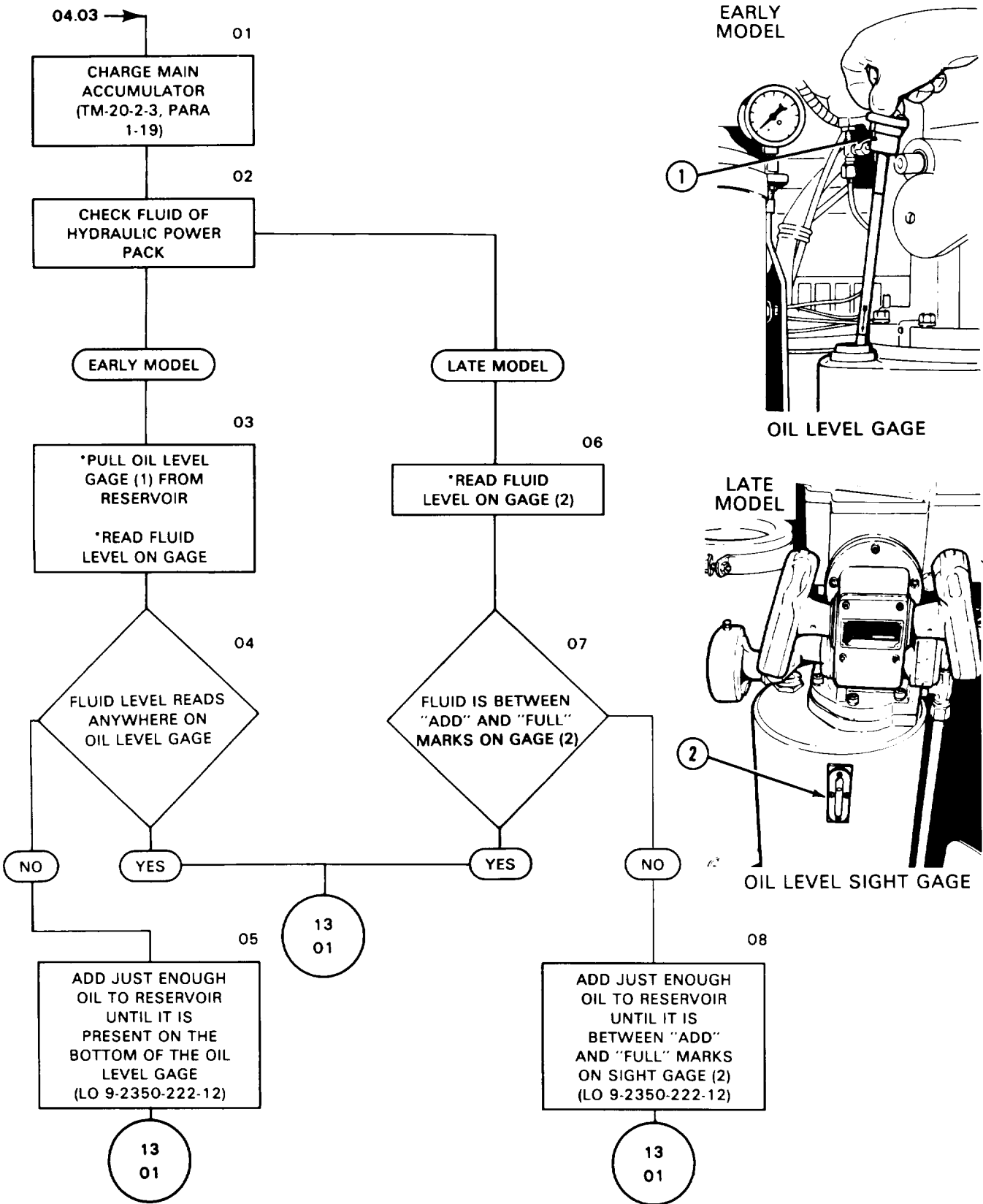

4-1. TURRET TRAVERSE TROUBLESHOOTING (SHEET 9 OF 75)

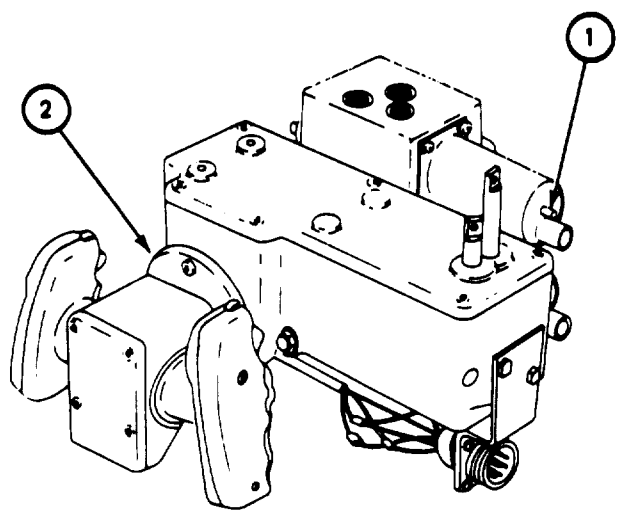
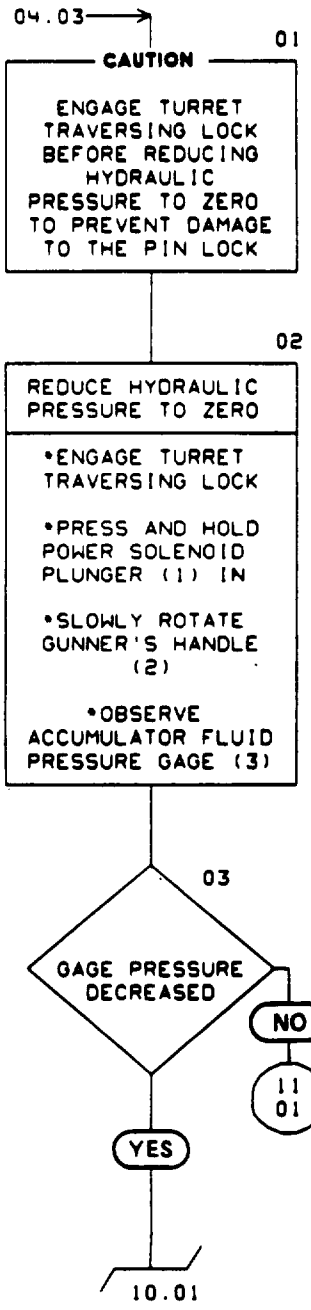

GUNNER'S CONTROL ASSEMBLY

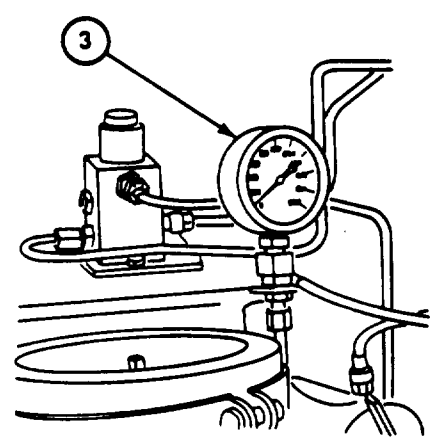

PRESSURE GAGE

4-1. TURRET TRAVERSE TROUBLESHOOTING (SHEET 10 OF 75)

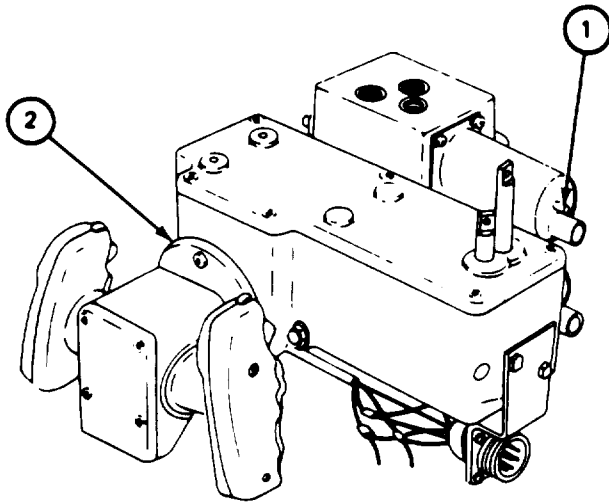
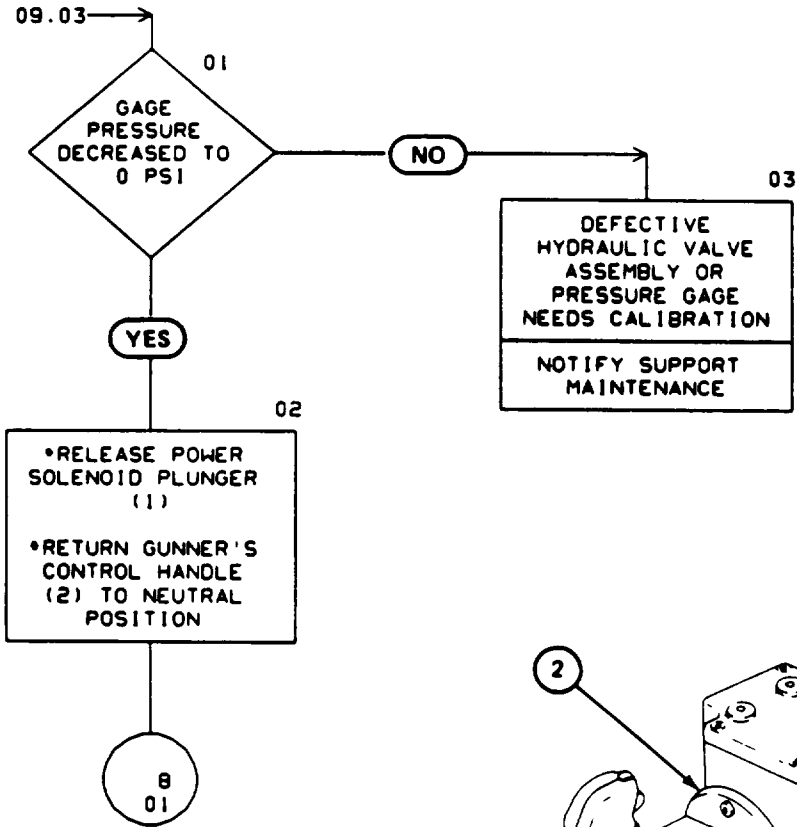

GUNNER'S CONTROL ASSEMBLY

4.1. TURRET TRAVERSE TROUBLESHOOTING (SHEET 11 OF 75)

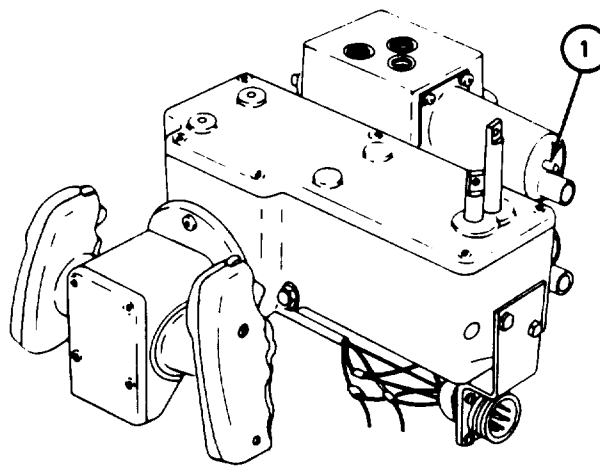
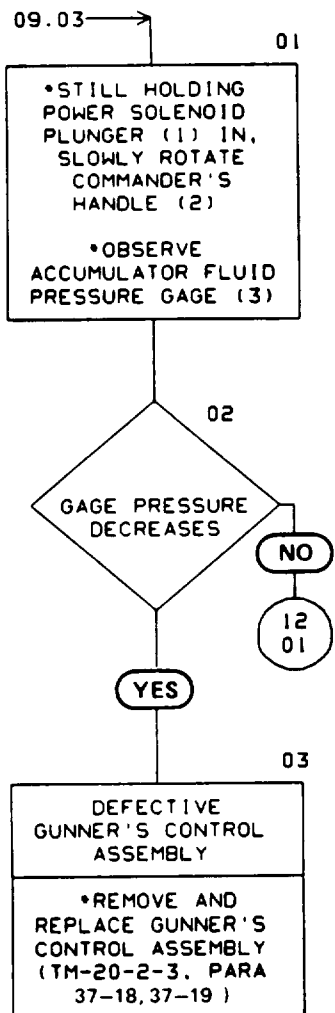

GUNNER'S CONTROL ASSEMBLY

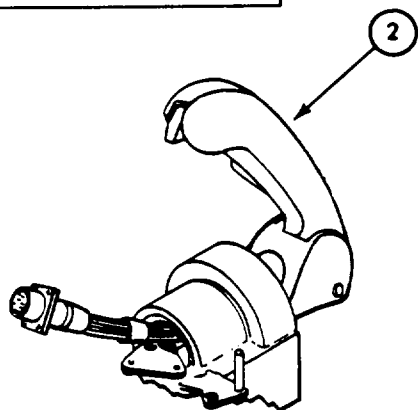

COMMANDER'S CONTROL HANDLE

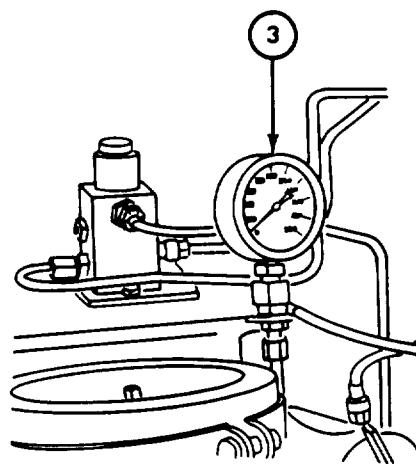

PRESSURE GAGE

4-1. TURRET TRAVERSE TROUBLESHOOTING (SHEET 12 OF 75)

11.02 →

01

*STILL HOLDING POWER SOLENOID PLUNGER (1) IN, SLOWLY ELEVATE GUNNER'S HANDLE (2)

*OBSERVE ACCUMULATOR PRESSURE GAGE (3)

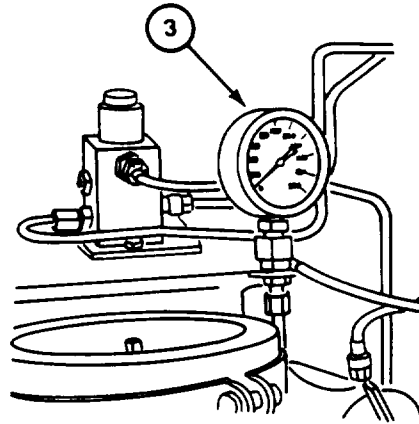

PRESSURE GAGE

02

GAGE PRESSURE DECREASES

NO

04

DEFECTIVE HYDRAULIC VALVE ASSEMBLY

*NOTIFY SUPPORT MAINTENANCE

YES

03

DEFECTIVE GUNNER'S CONTROL ASSEMBLY

*REMOVE AND REPLACE GUNNER'S CONTROL ASSEMBLY (TM-20-2-3, PARA 37-18, 37-19)

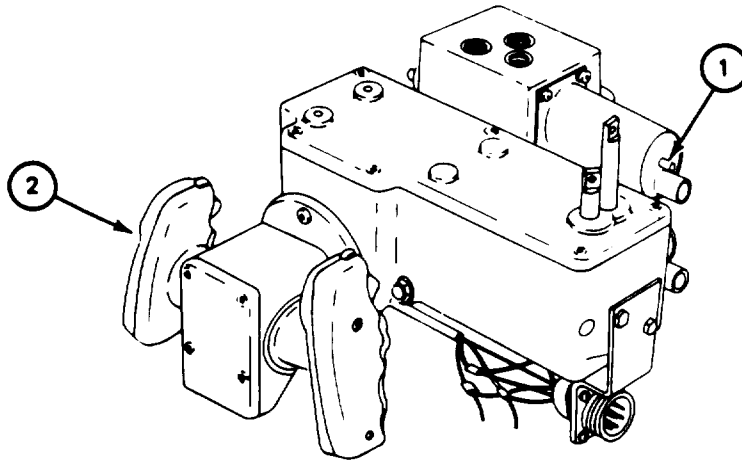

GUNNER'S CONTROL ASSEMBLY

4-1. TURRET TRAVERSE TROUBLESHOOTING (SHEET 13 OF 75)

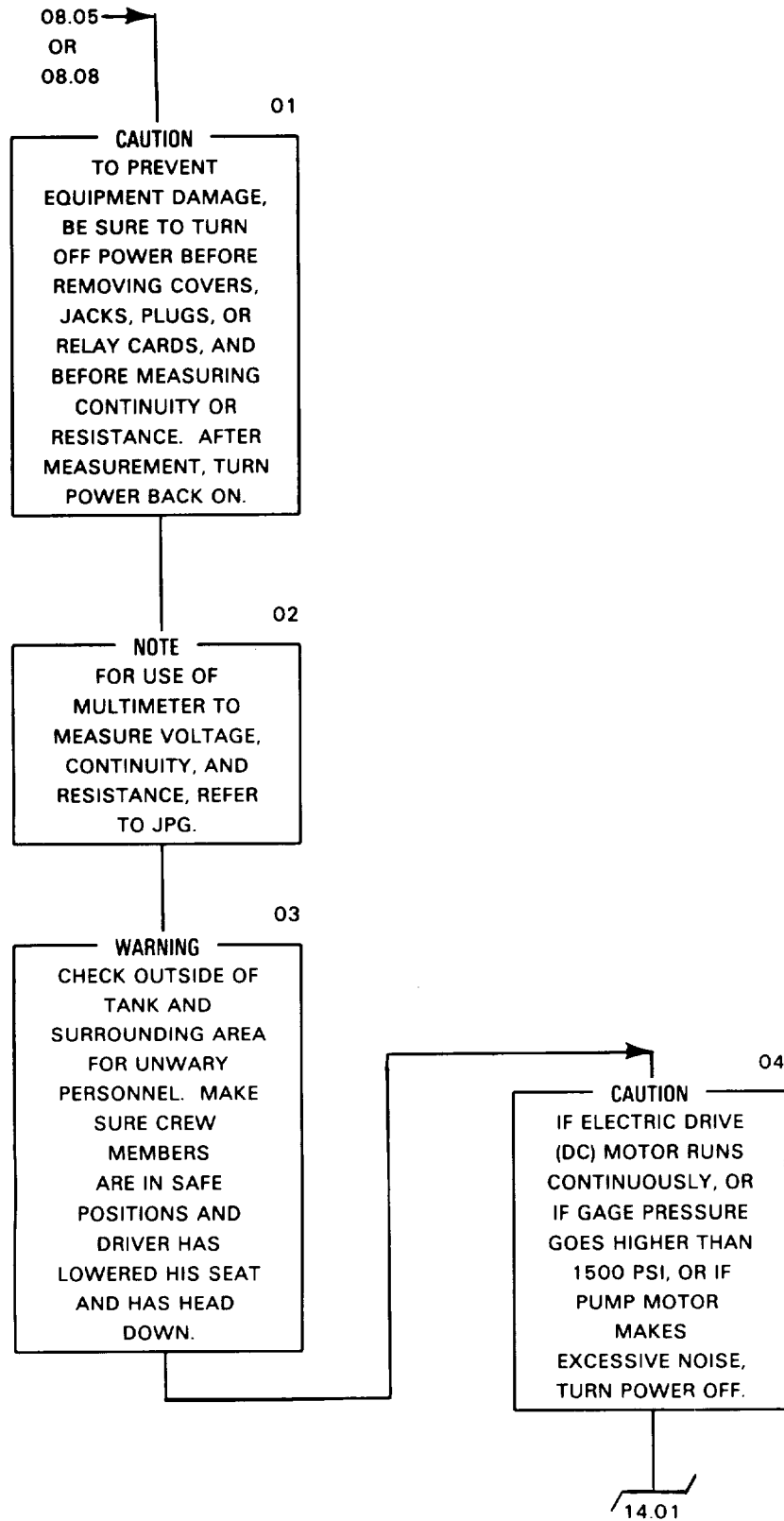

4-1. TURRET TRAVERSE TROUBLESHOOTING (SHEET 14 OF 75)

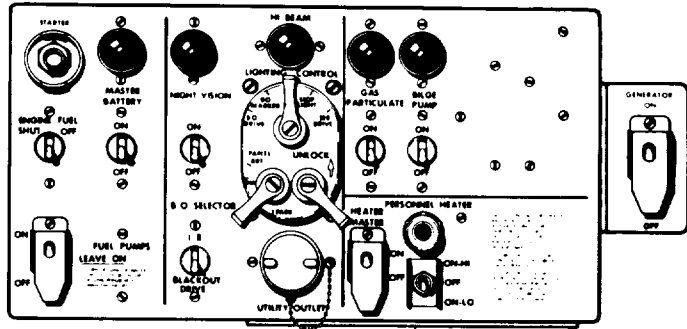
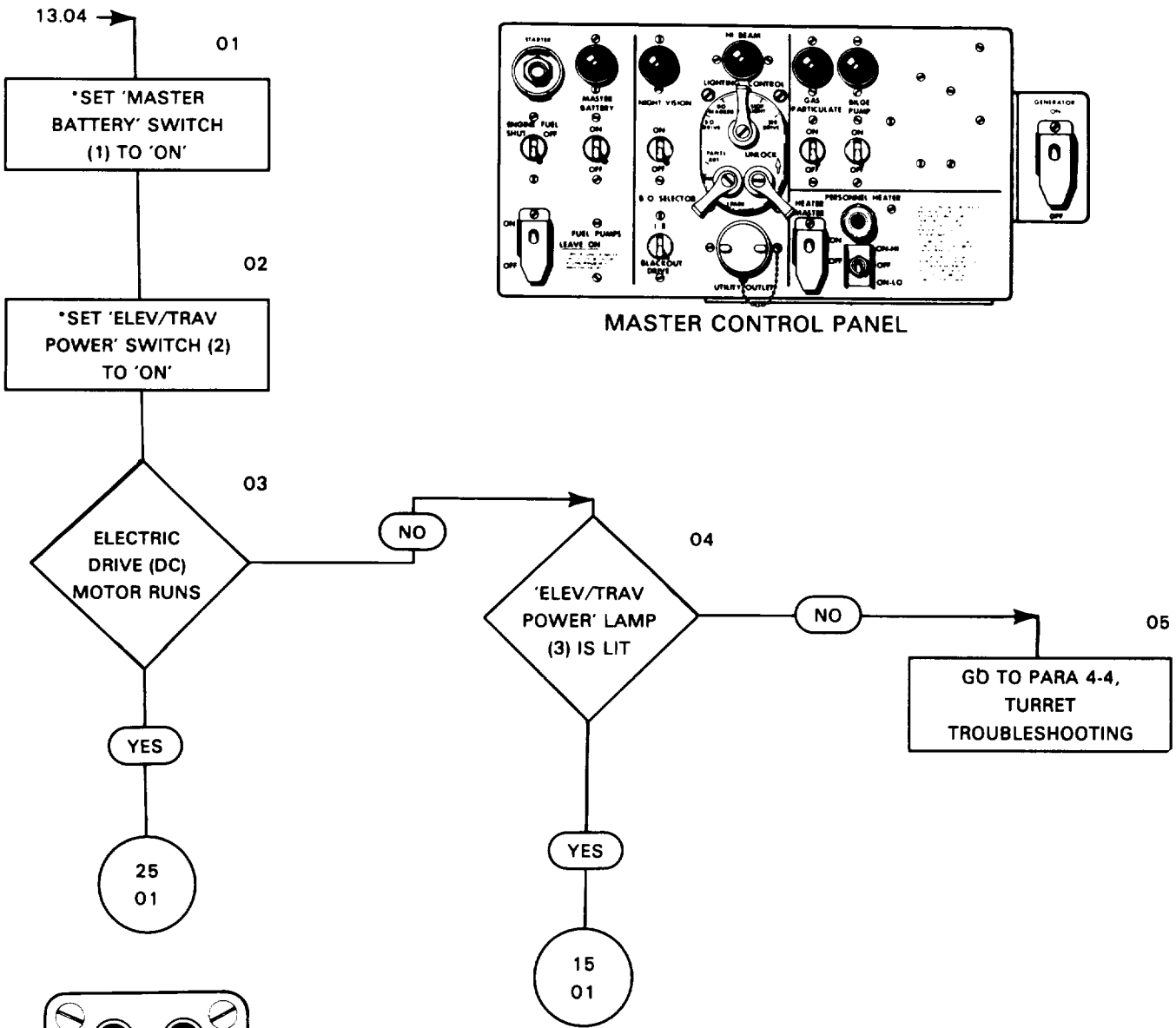

MASTER CONTROL PANEL

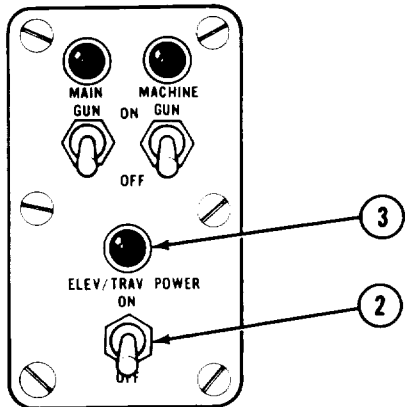

GUNNER'S CONTROL BOX

4-1. TURRET TRAVERSE TROUBLESHOOTING (SHEET 15 OF 75)

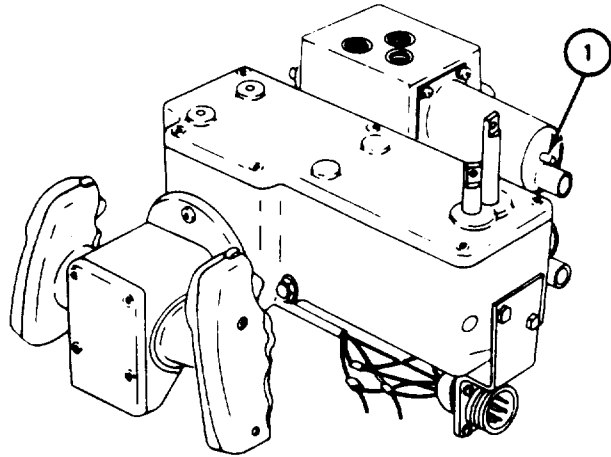
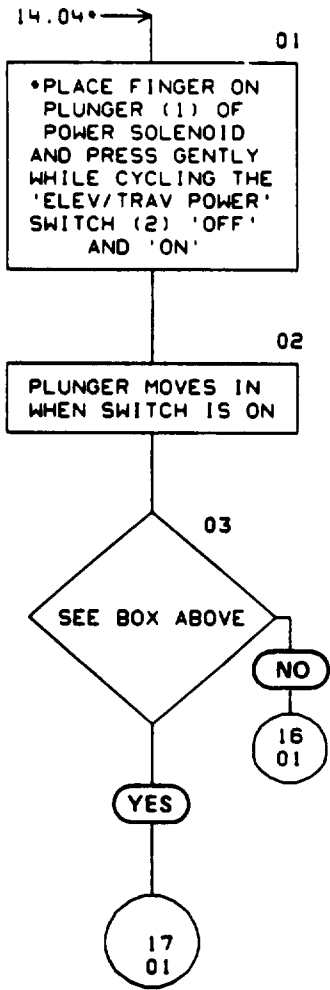

GUNNER'S CONTROL ASSEMBLY

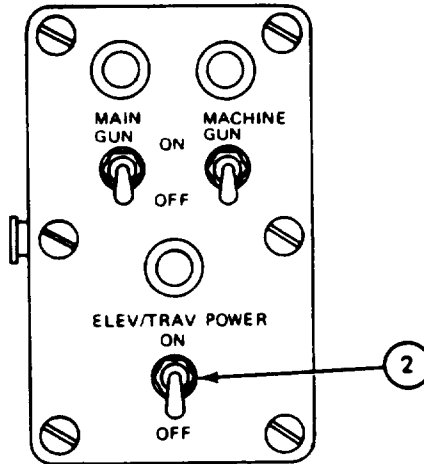

GUNNER'S CONTROL BOX

4-1. TURRET TRAVERSE TROUBLESHOOTING (SHEET 16 OF 75)

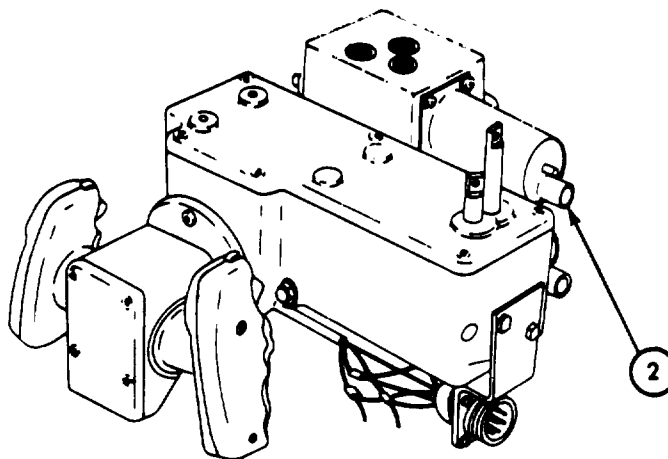
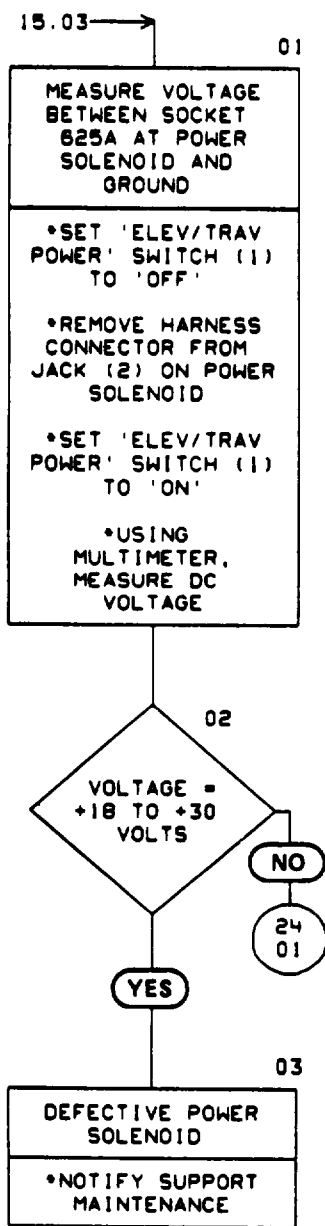

GUNNER'S CONTROL ASSEMBLY

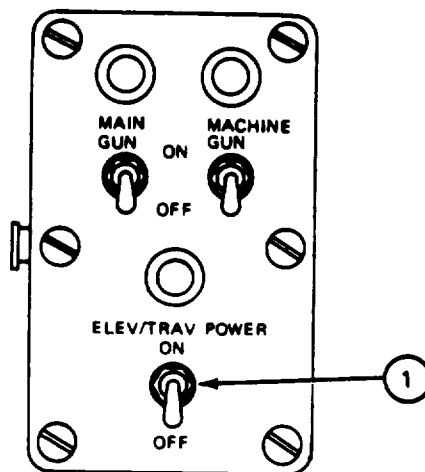

GUNNER'S CONTROL BOX

4-1. TURRET TRAVERSE TROUBLESHOOTING (SHEET 17 OF 75)

15.03 →

01

MEASURE VOLTAGE BETWEEN SOCKET A OF HARNESS CONNECTOR TO PRESSURE SWITCH AND GROUND

- TRAVERSE TURRET TO GAIN ACCESS TO PRESSURE SWITCH FROM DRIVER'S COMPARTMENT
- ENGAGE TURRET TRAVERSING LOCK (TM-10)
- TURN 'ELEV/TRAV POWER' SWITCH (1) TO 'OFF'
- REMOVE HARNESS CONNECTOR FROM JACK (2) ON PRESSURE SWITCH
- TURN 'ELEV/TRAV POWER' SWITCH (1) TO 'ON'
- USING MULTIMETER, MEASURE DC VOLTAGE

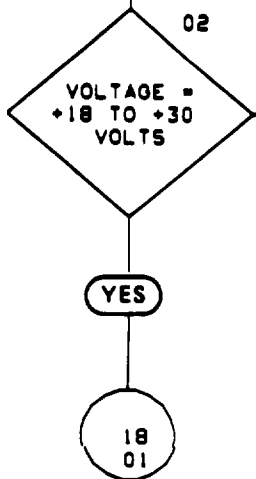
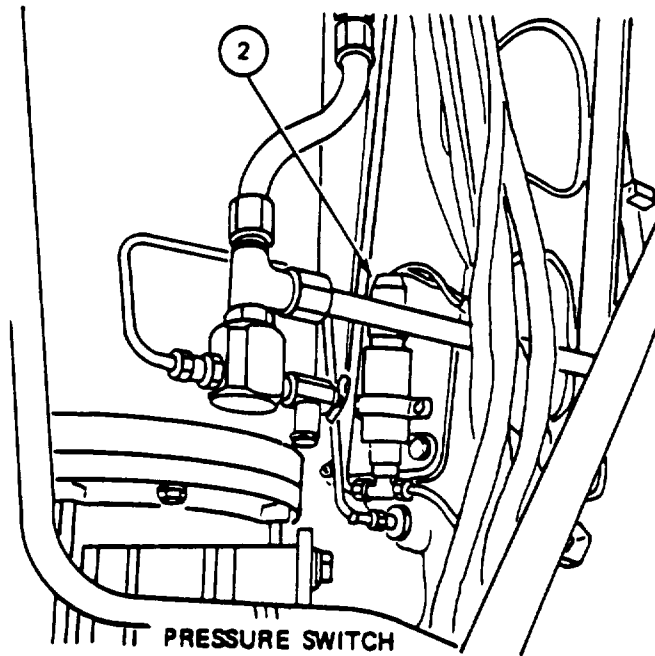

NO

03

DEFECTIVE TURRET CONTROL WIRING HARNESS

• NOTIFY SUPPORT MAINTENANCE

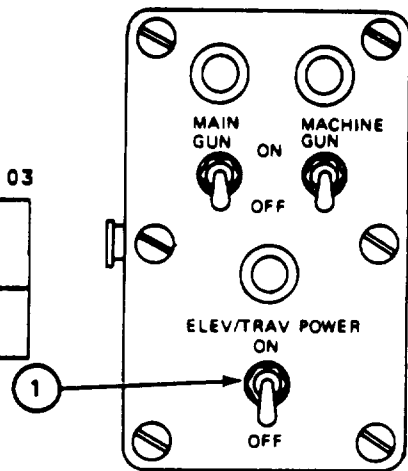

GUNNER'S CONTROL BOX

4-1. TURRET TRAVERSE TROUBLESHOOTING (SHEET 18 OF 75)

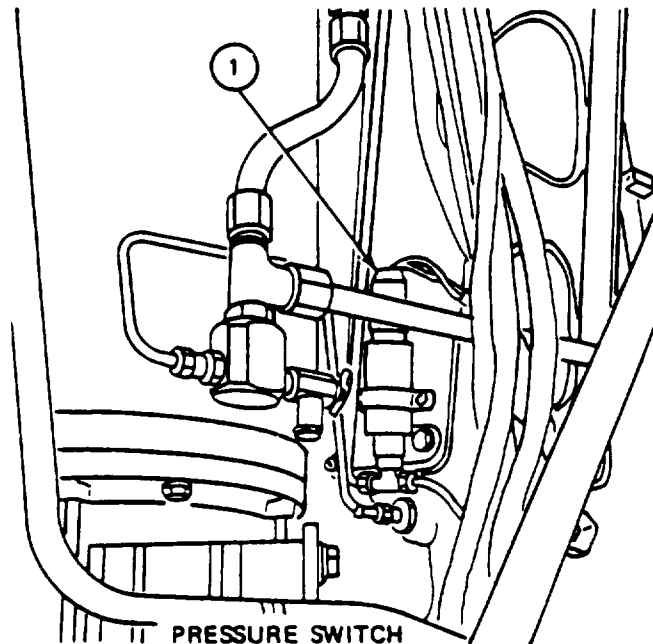
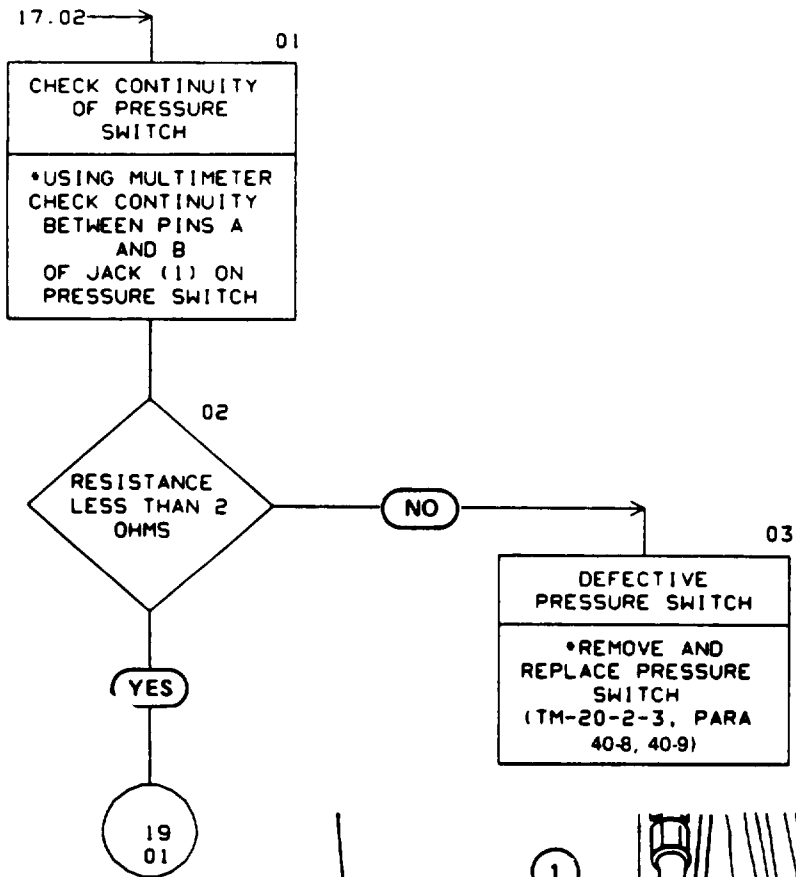

4-1. TURRET TRAVERSE TROUBLESHOOTING (SHEET 19 OF 75)

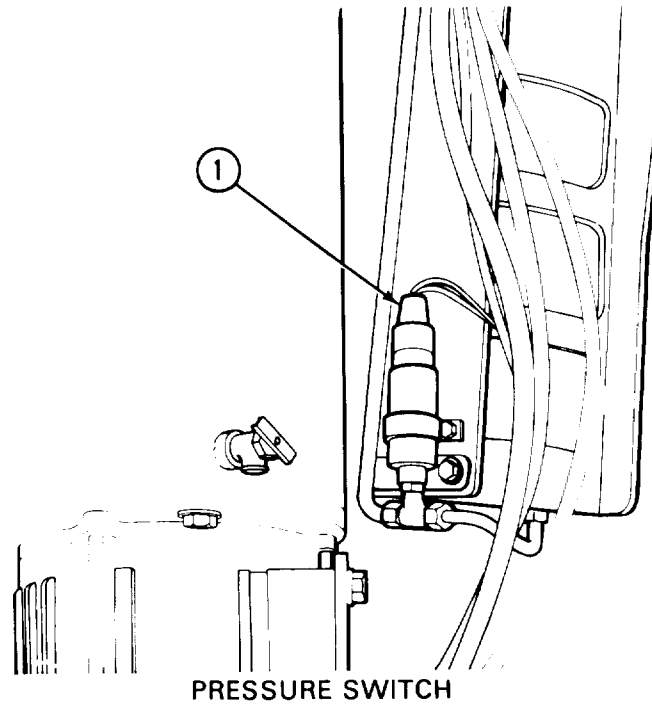
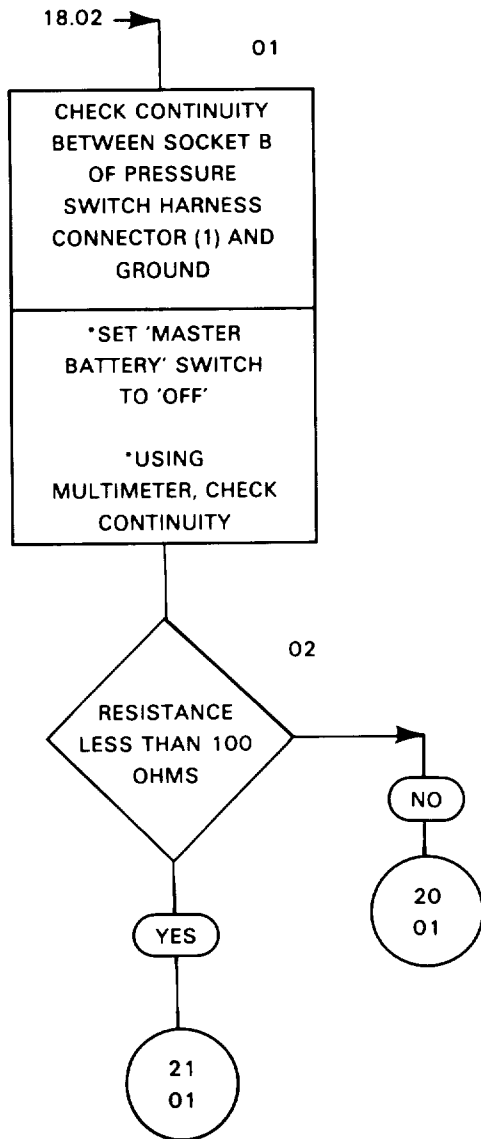

4-1. TURRET TRAVERSE TROUBLESHOOTING (SHEET 20 OF 75)

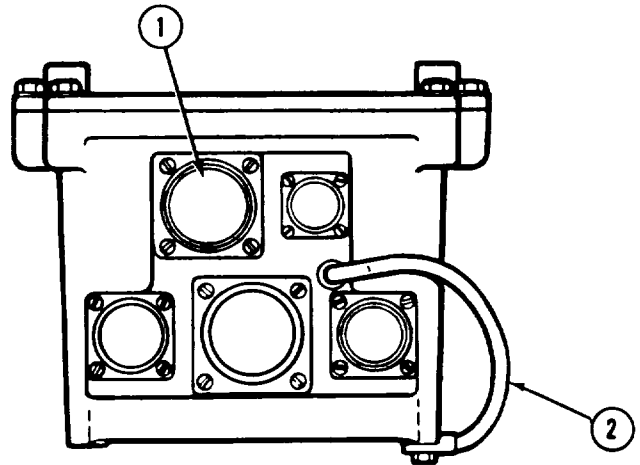
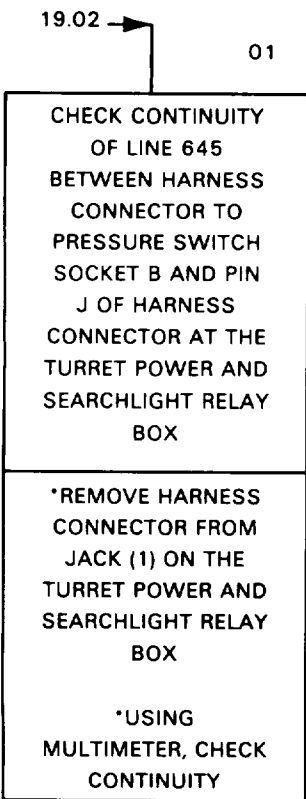

TURRET POWER AND SEARCHLIGHT RELAY BOX

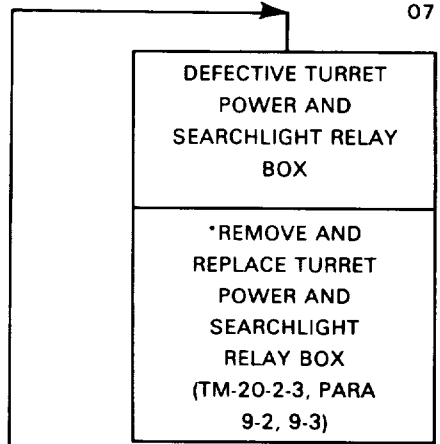
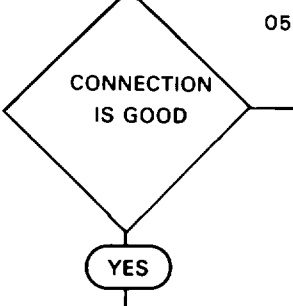
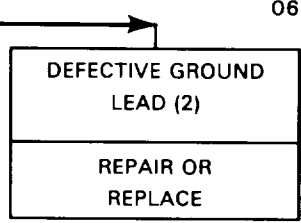
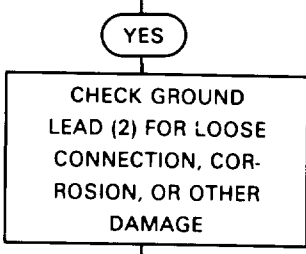
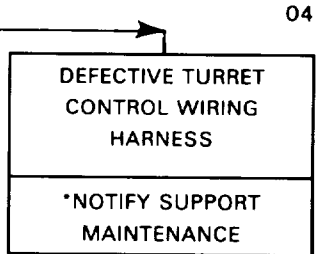
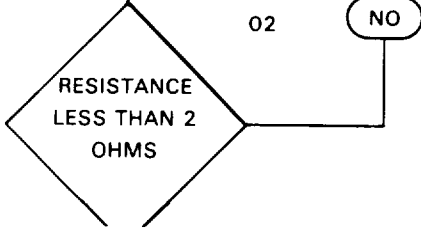

4-1. TURRET TRAVERSE TROUBLESHOOTING (SHEET 21 OF 75)

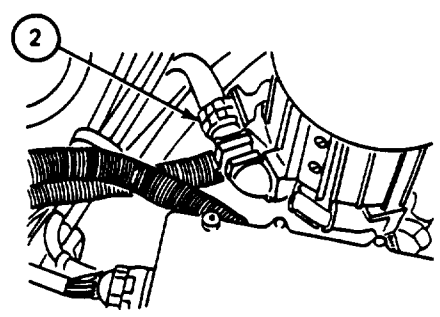
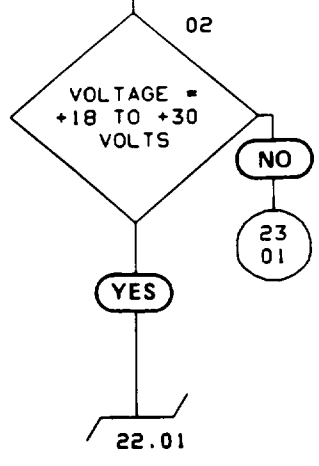
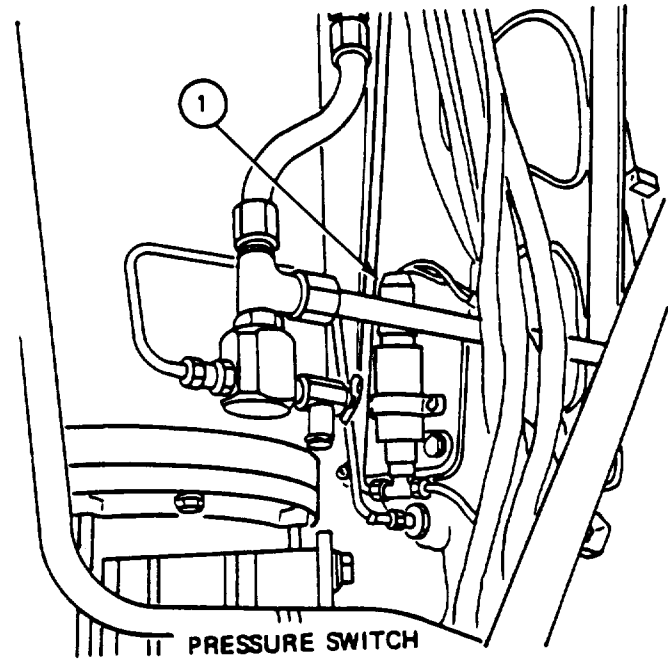
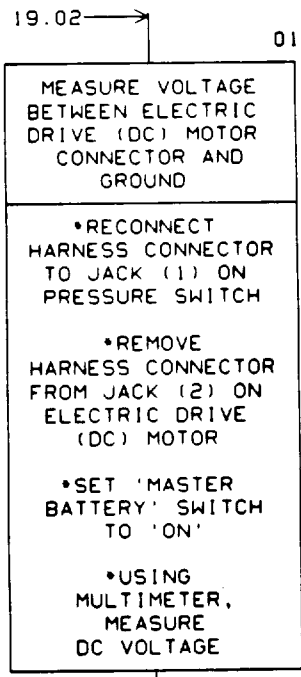

ELECTRIC DRIVE (DC) MOTOR

4-1. TURRET TRAVERSE TROUBLESHOOTING (SHEET 22 OF 75)

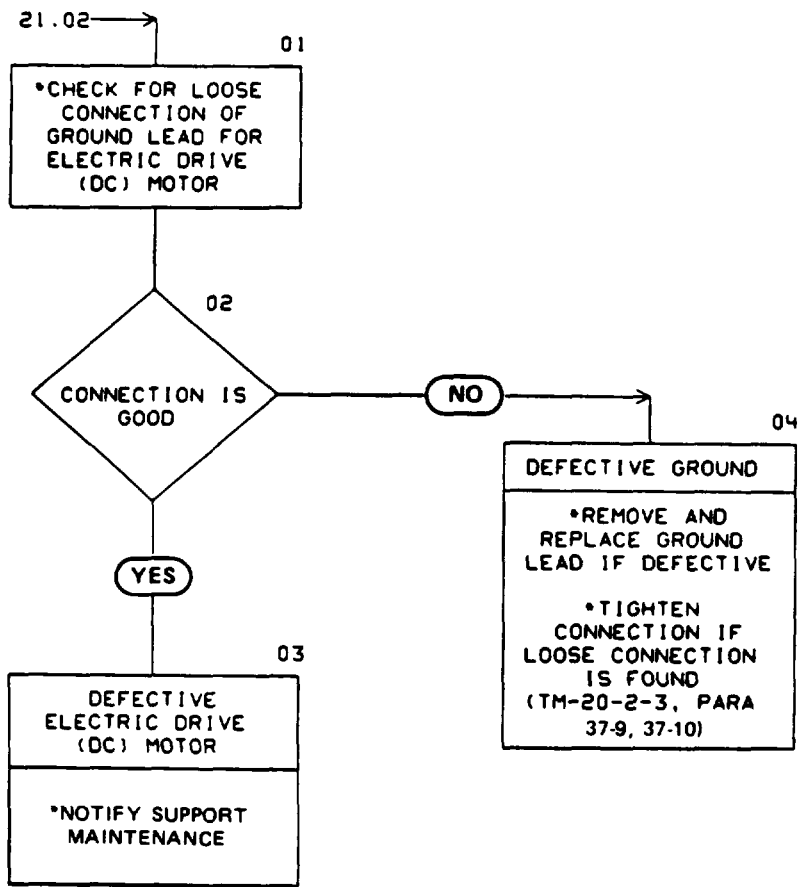

4-1. TURRET TRAVERSE TROUBLESHOOTING (SHEET 23 OF 75)

21.02 →

01

CHECK CONTINUITY OF LINE 104 BETWEEN HARNESS CONNECTOR OF ELECTRIC DRIVE (DC) MOTOR AND HARNESS CONNECTOR AT THE TURRET POWER AND SEARCHLIGHT RELAY BOX

•SET 'MASTER BATTERY' SWITCH TO 'OFF'

•REMOVE HARNESS CONNECTOR FROM JACK (1) ON TURRET POWER AND SEARCHLIGHT RELAY BOX

•USING MULTIMETER, CHECK CONTINUITY

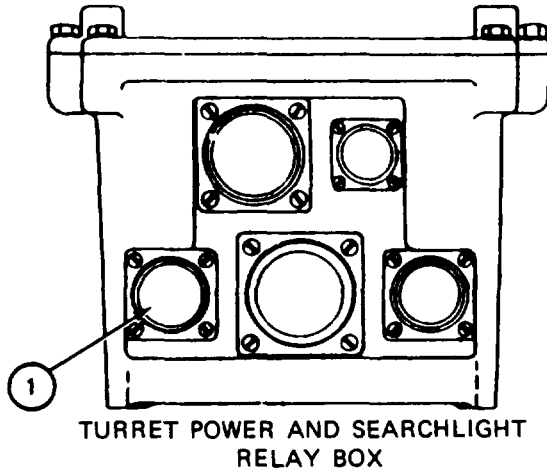

23.03 →

NOTE 05

CONTINUED FROM A PRIOR COLUMN

•REMOVE AND REPLACE TURRET POWER AND SEARCHLIGHT RELAY BOX (TM-20-2-3, PARA 9-2, 9-3)

02

RESISTANCE LESS THAN 2 OHMS

YES

03

DEFECTIVE TURRET POWER AND SEARCHLIGHT RELAY BOX

NO

04

DEFECTIVE TURRET POWER AND SEARCHLIGHT RELAY BOX TO POWER PACK MOTOR CABLE

•REMOVE AND REPLACE TURRET POWER AND SEARCHLIGHT RELAY BOX TO POWER PACK MOTOR CABLE (TM-20-2-3 PARA 2-13, 2-14)

23.05

4-1. TURRET TRAVERSE TROUBLESHOOTING (SHEET 24 OF 75)

16.02 → 01

CHECK CONTINUITY BETWEEN SOCKET E OF HARNESS CONNECTOR AT GUNNER'S CONTROL BOX AND SOCKET A OF HARNESS CONNECTOR AT PRESSURE SWITCH

• SET 'MASTER BATTERY' SWITCH TO 'OFF'

• REMOVE HARNESS CONNECTOR FROM JACK (1) ON PRESSURE SWITCH

• REMOVE HARNESS CONNECTOR FROM JACK (2) ON GUNNER'S CONTROL BOX

• USING MULTIMETER, CHECK CONTINUITY

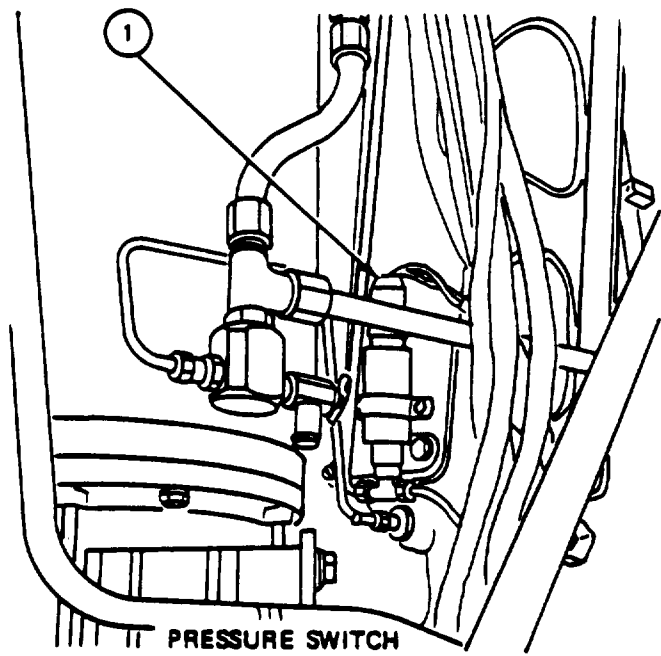

24.03 → NOTE 05

CONTINUED FROM A PRIOR COLUMN

• REMOVE AND REPLACE GUNNER'S CONTROL BOX (TM-20-2-3, PARA 10-2, 10-3)

02

RESISTANCE LESS THAN 2 OHMS

YES

NO

04

DEFECTIVE TURRET CONTROL WIRING HARNESS

• NOTIFY SUPPORT MAINTENANCE

03

DEFECTIVE GUNNER'S CONTROL BOX

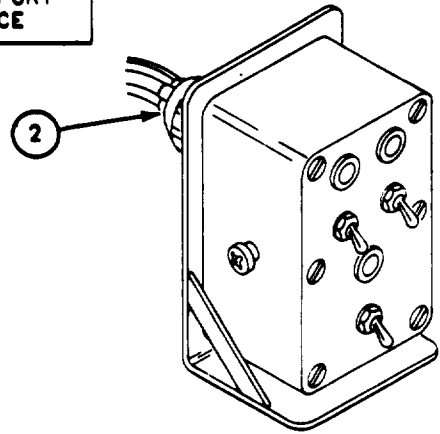

GUNNER'S CONTROL BOX

24.05

4.1. TURRET TRAVERSE TROUBLESHOOTING (SHEET 25 OF 75)

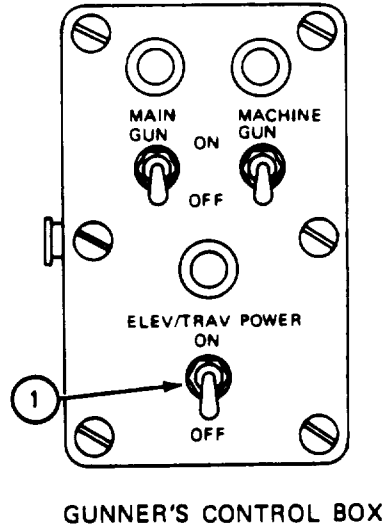
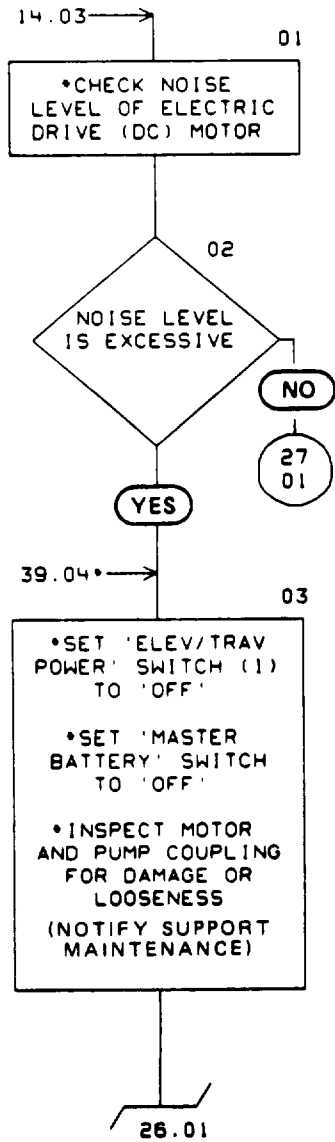

4-1. TURRET TRAVERSE TROUBLESHOOTING (SHEET 26 OF 75)

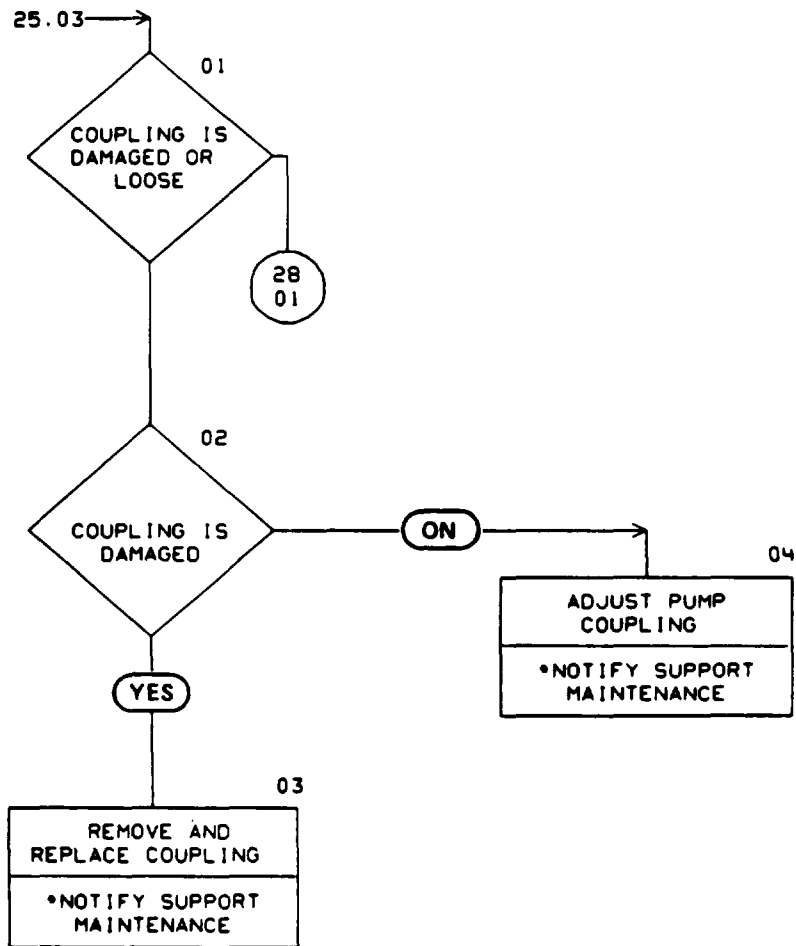

4-1. TURRET TRAVERSE TROUBLESHOOTING (SHEET 27 OF 75)

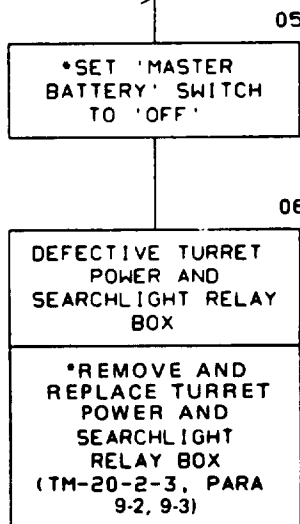
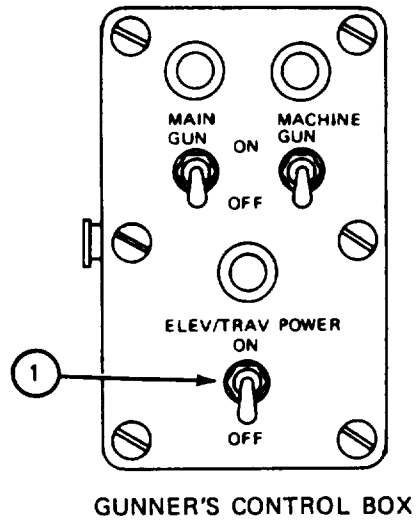
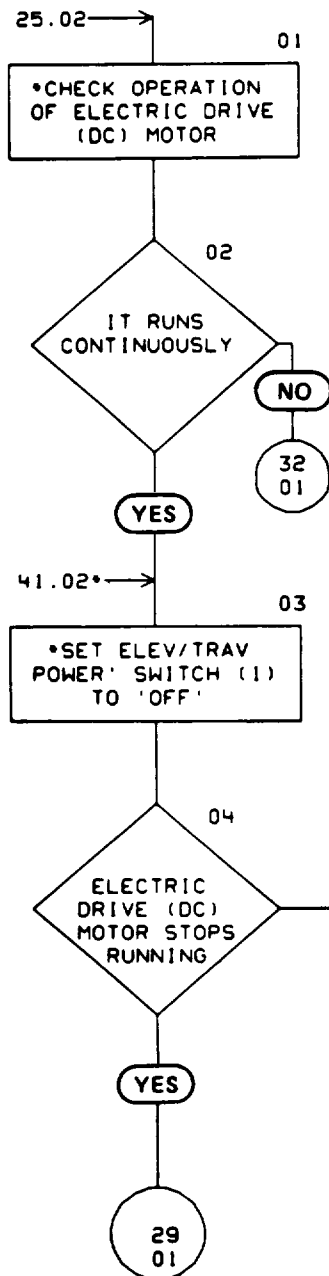

4.1. TURRET TRAVERSE TROUBLESHOOTING (SHEET 28 OF 75)

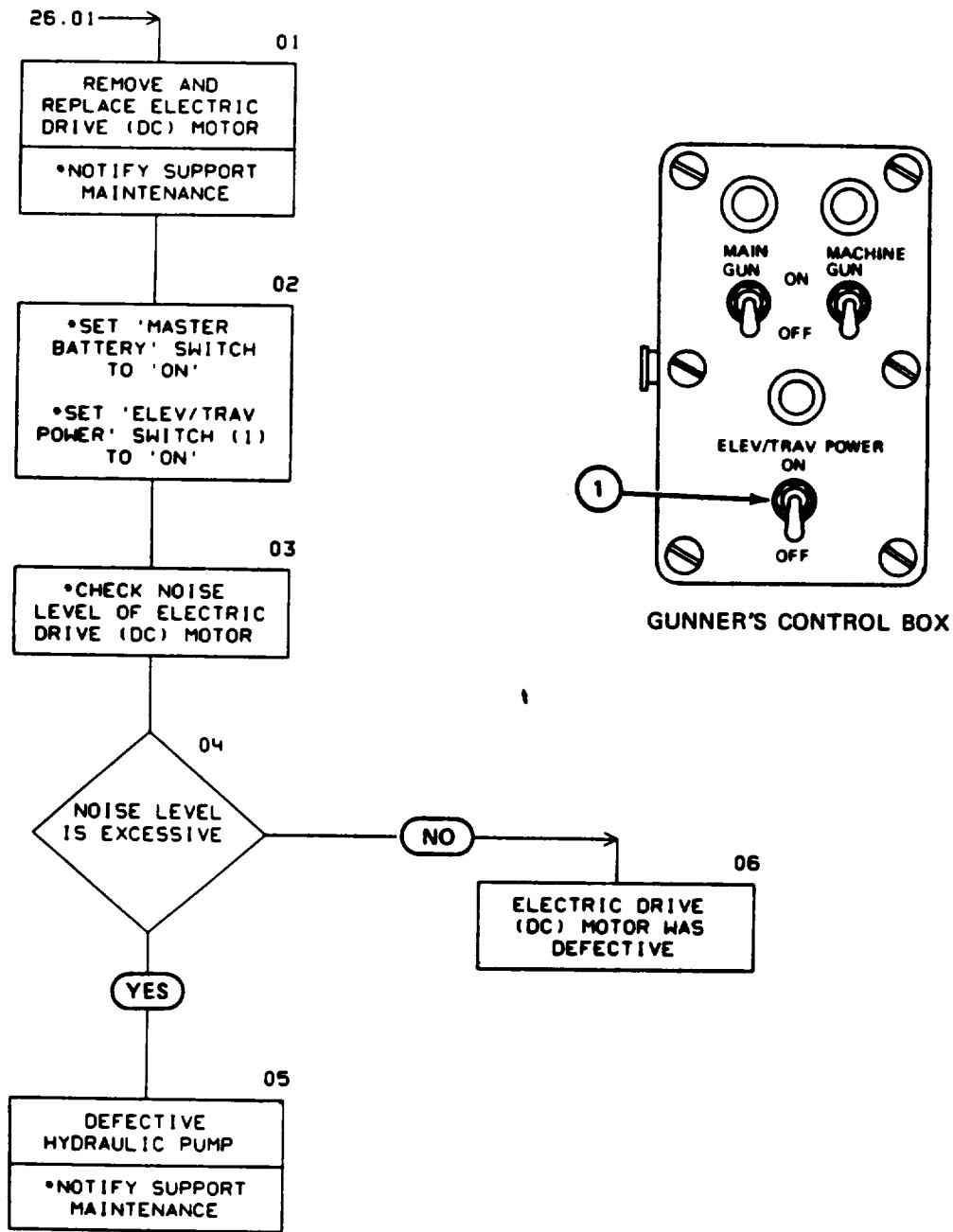

4-1. TURRET TRAVERSE TROUBLESHOOTING (SHEET 29 OF 75)

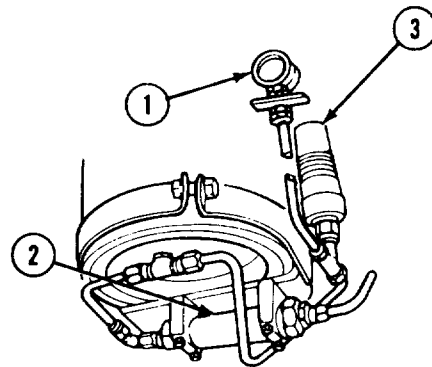
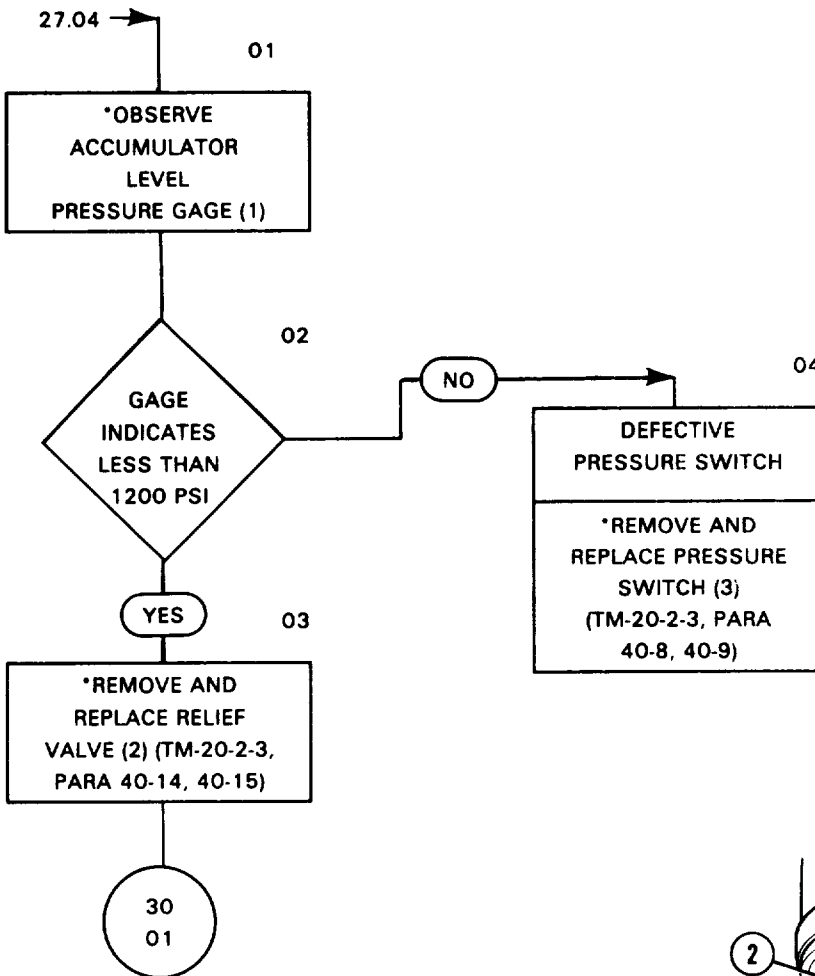

MAIN ACCUMULATOR HYDRAULIC POWER PACK

4-1. TURRET TRAVERSE TROUBLESHOOTING (SHEET 30 OF 75)

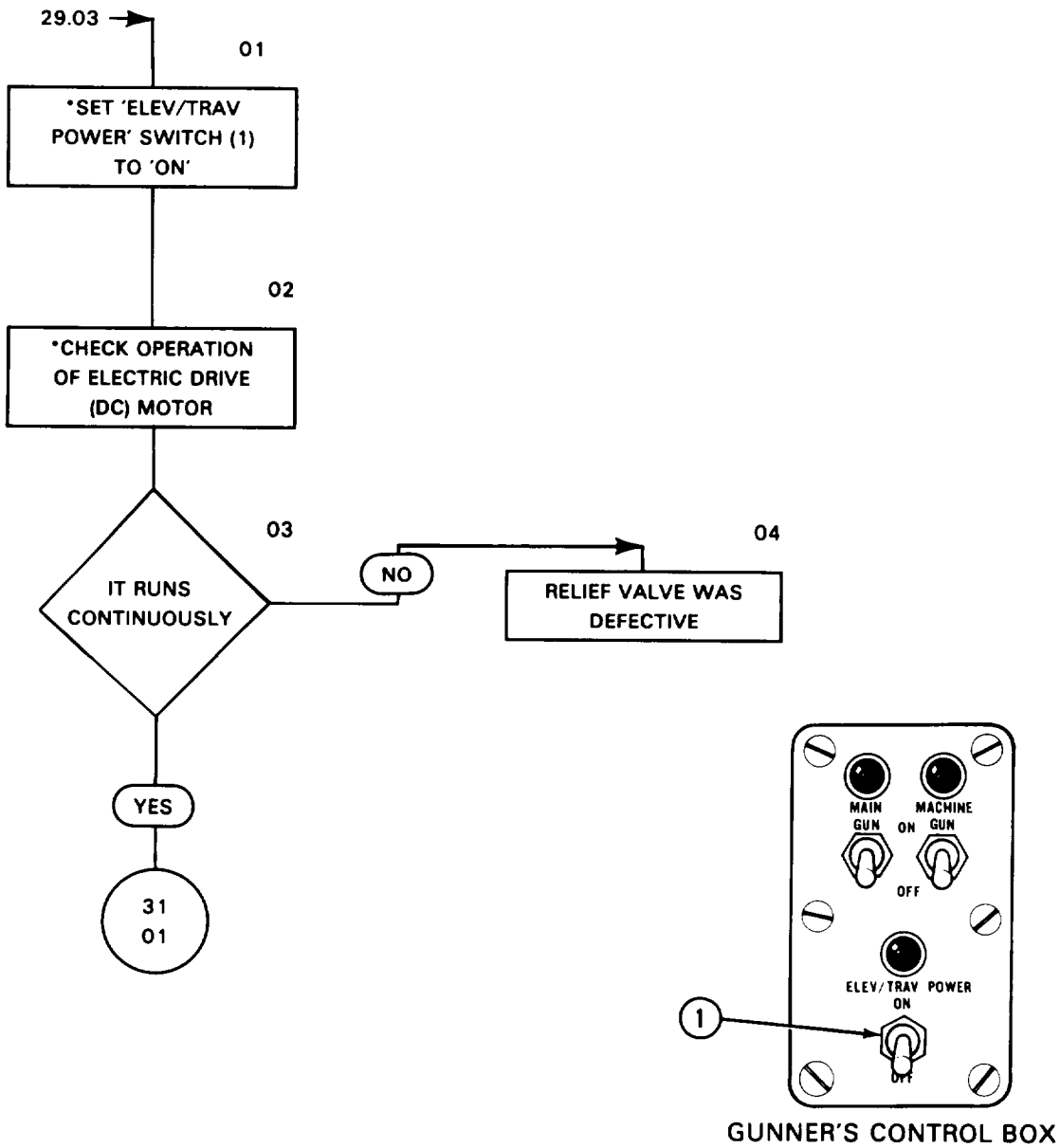

4-1. TURRET TRAVERSE TROUBLESHOOTING (SHEET 31 OF 75)

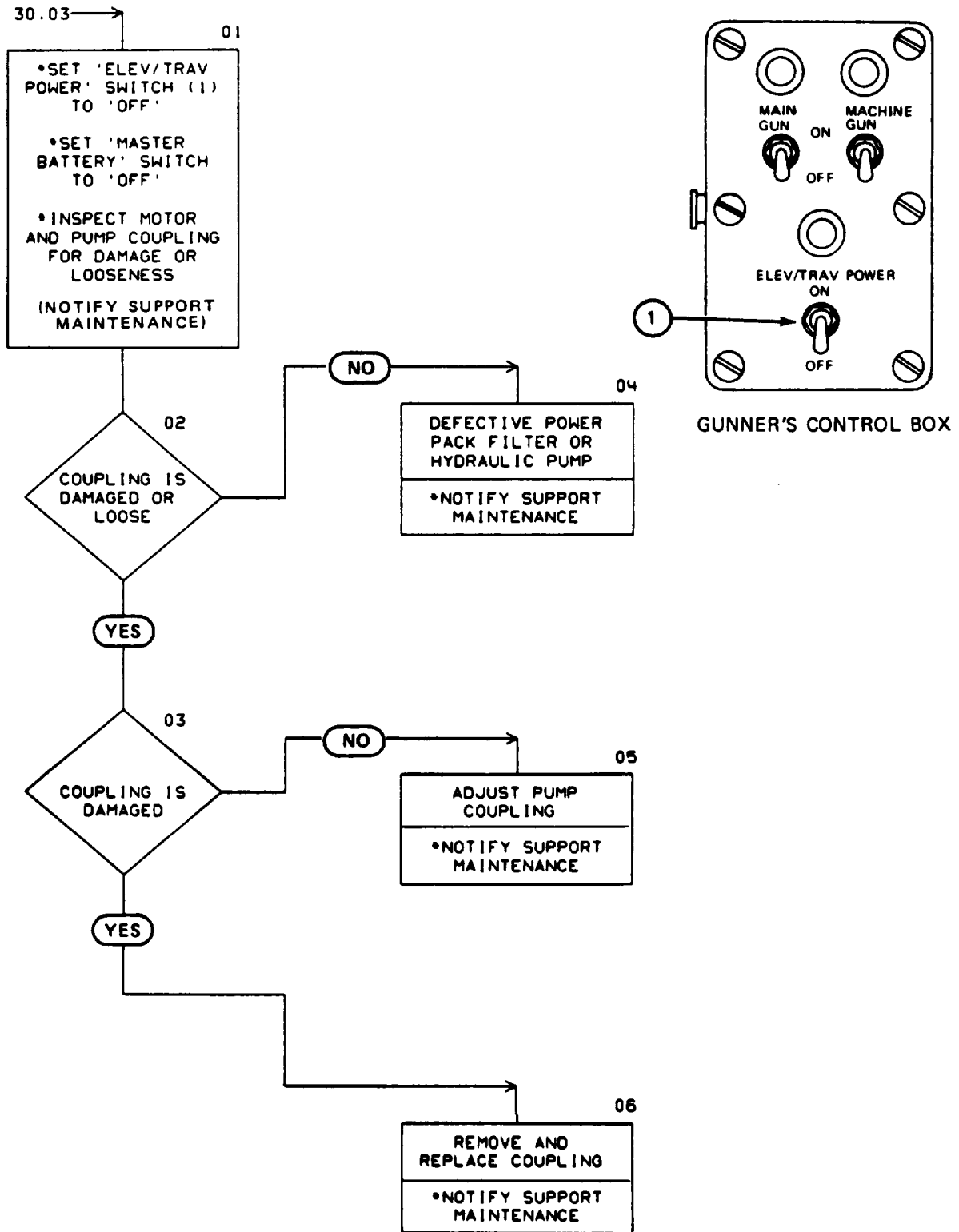

4-1. TURRET TRAVERSE TROUBLESHOOTING (SHEET 32 OF 75)

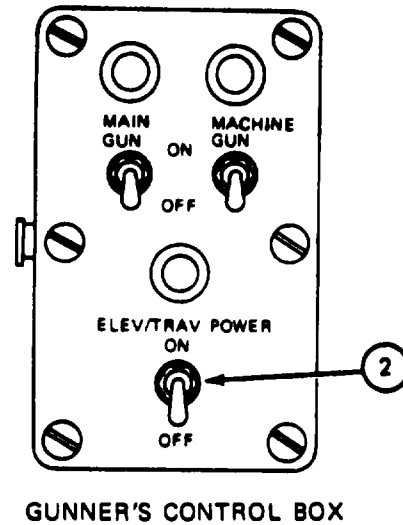
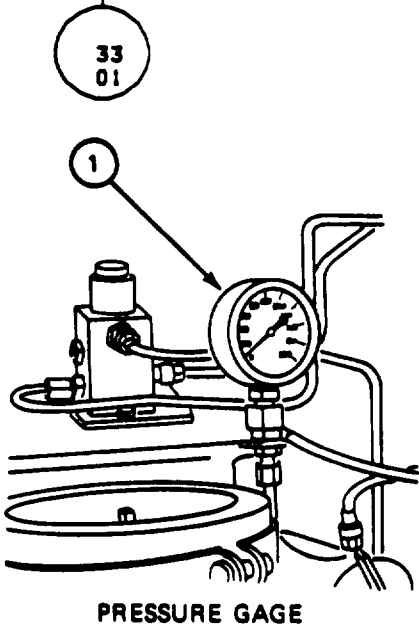
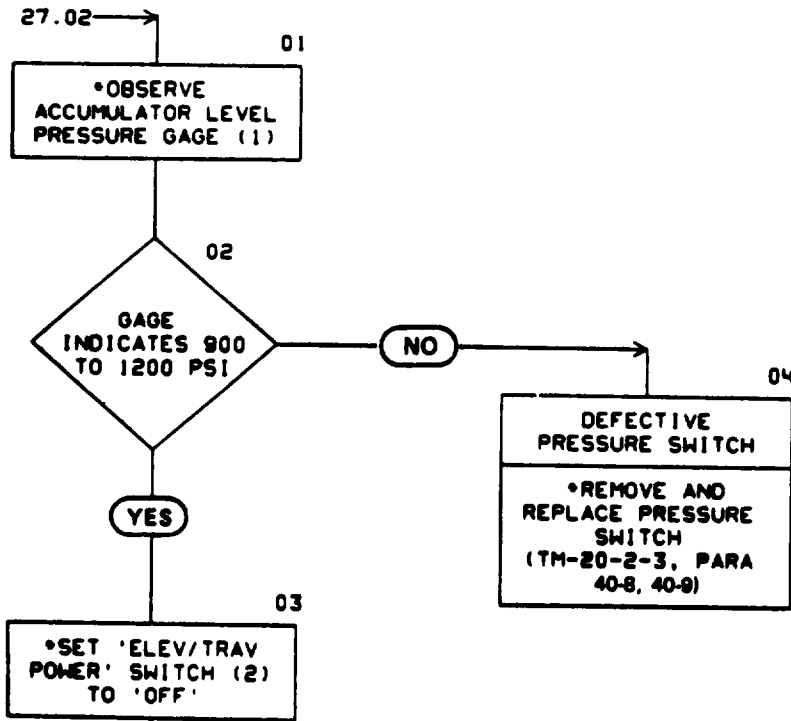

4-1. TURRET TRAVERSE TROUBLESHOOTING (SHEET 33 OF 75)

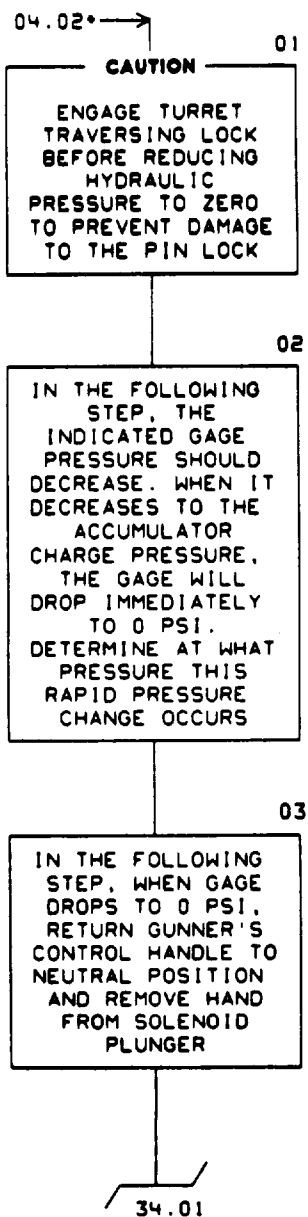

4-1. TURRET TRAVERSE TROUBLESHOOTING (SHEET 34 OF 75)

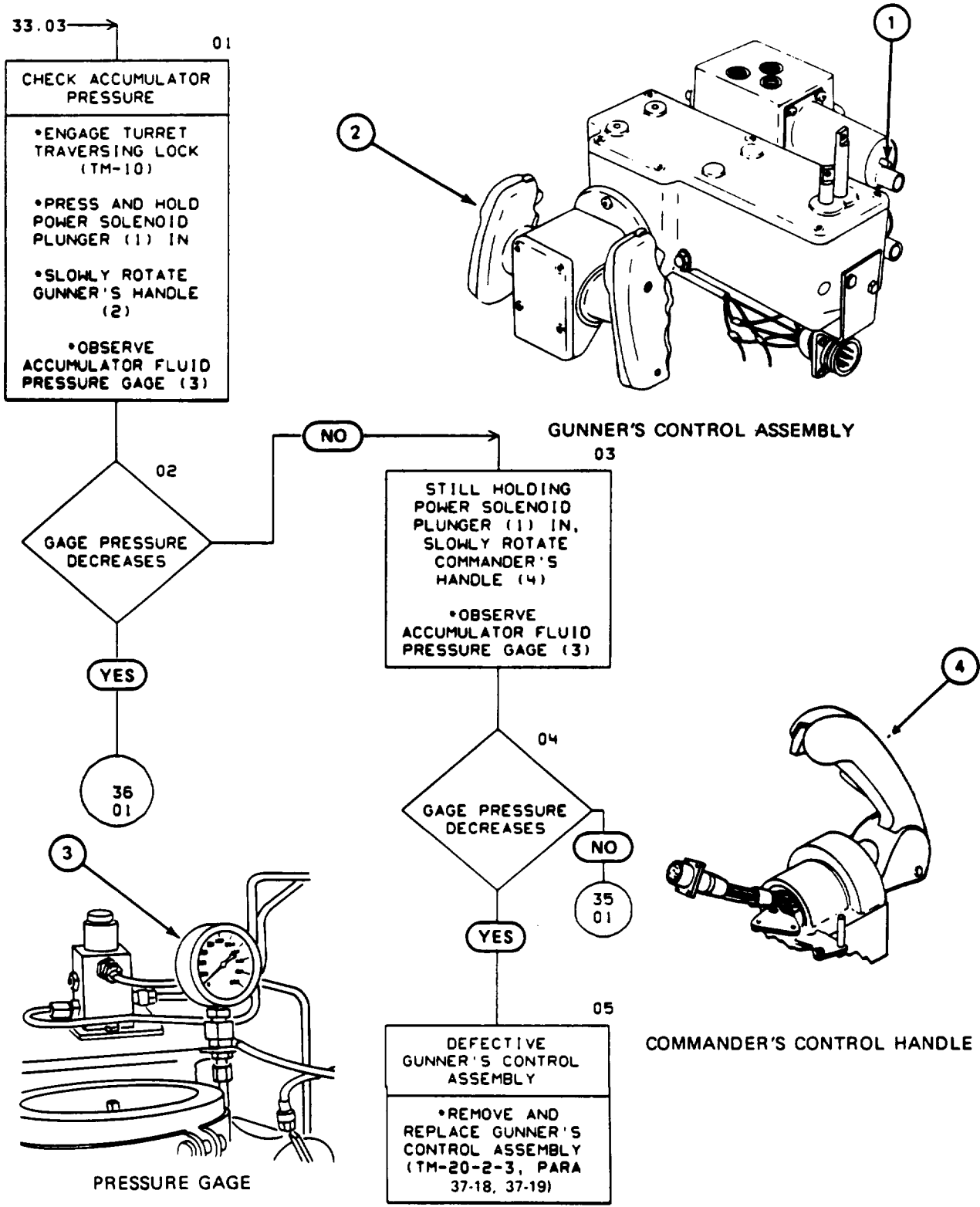

4-1. TURRET TRAVERSE TROUBLESHOOTING (SHEET 35 OF 75)

34.04 →

01

STILL HOLDING
POWER SOLENOID
PLUNGER (1) IN,
SLOWLY ELEVATE
GUNNER'S HANDLE
(2)

*OBSERVE
ACCUMULATOR FLUID
PRESSURE GAGE (3)

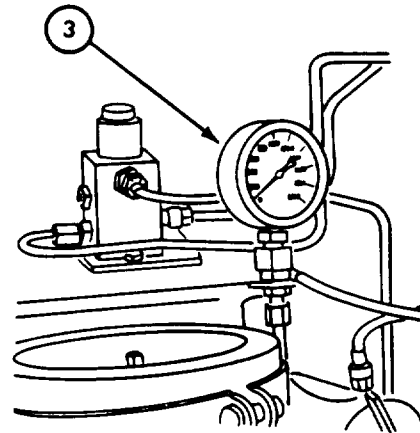

PRESSURE GAGE

02

GAGE PRESSURE
DECREASES

NO

04

DEFECTIVE POWER
VALVE OF
HYDRAULIC VALVE
ASSEMBLY

*NOTIFY SUPPORT
MAINTENANCE

YES

03

DEFECTIVE
TRAVERSE VALVE OF
HYDRAULIC VALVE
ASSEMBLY

*NOTIFY SUPPORT
MAINTENANCE

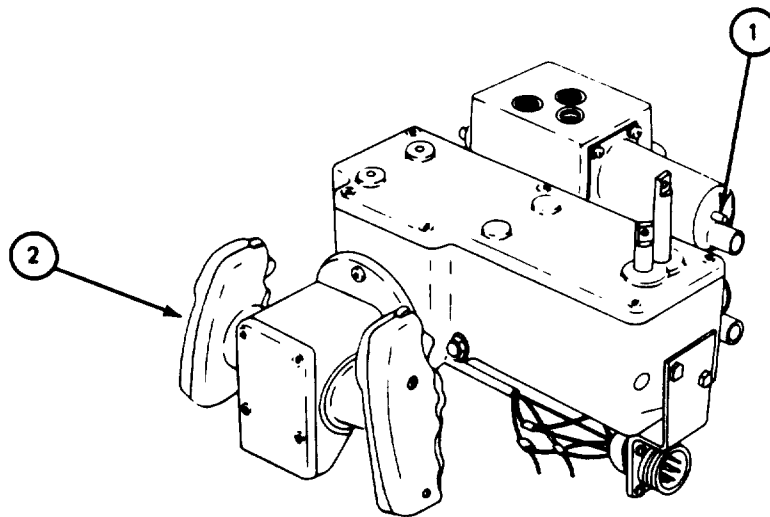

GUNNER'S CONTROL ASSEMBLY

4-1. TURRET TRAVERSE TROUBLESHOOTING (SHEET 36 OF 75)

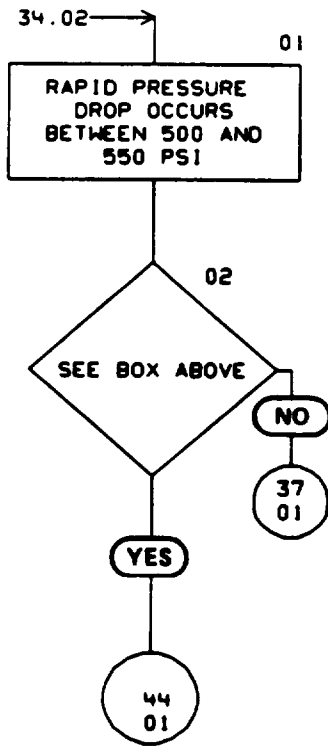

4-1. TURRET TRAVERSE TROUBLESHOOTING (SHEET 37 OF 75)

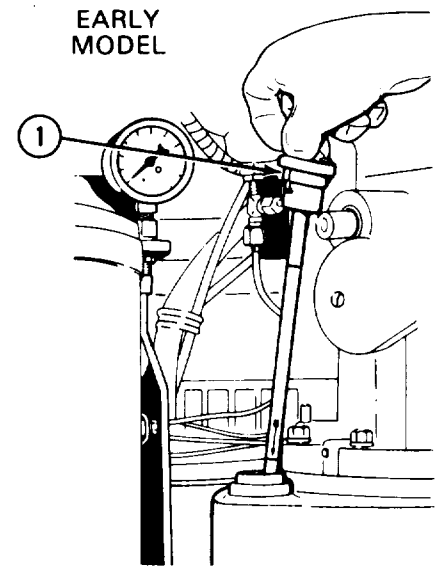
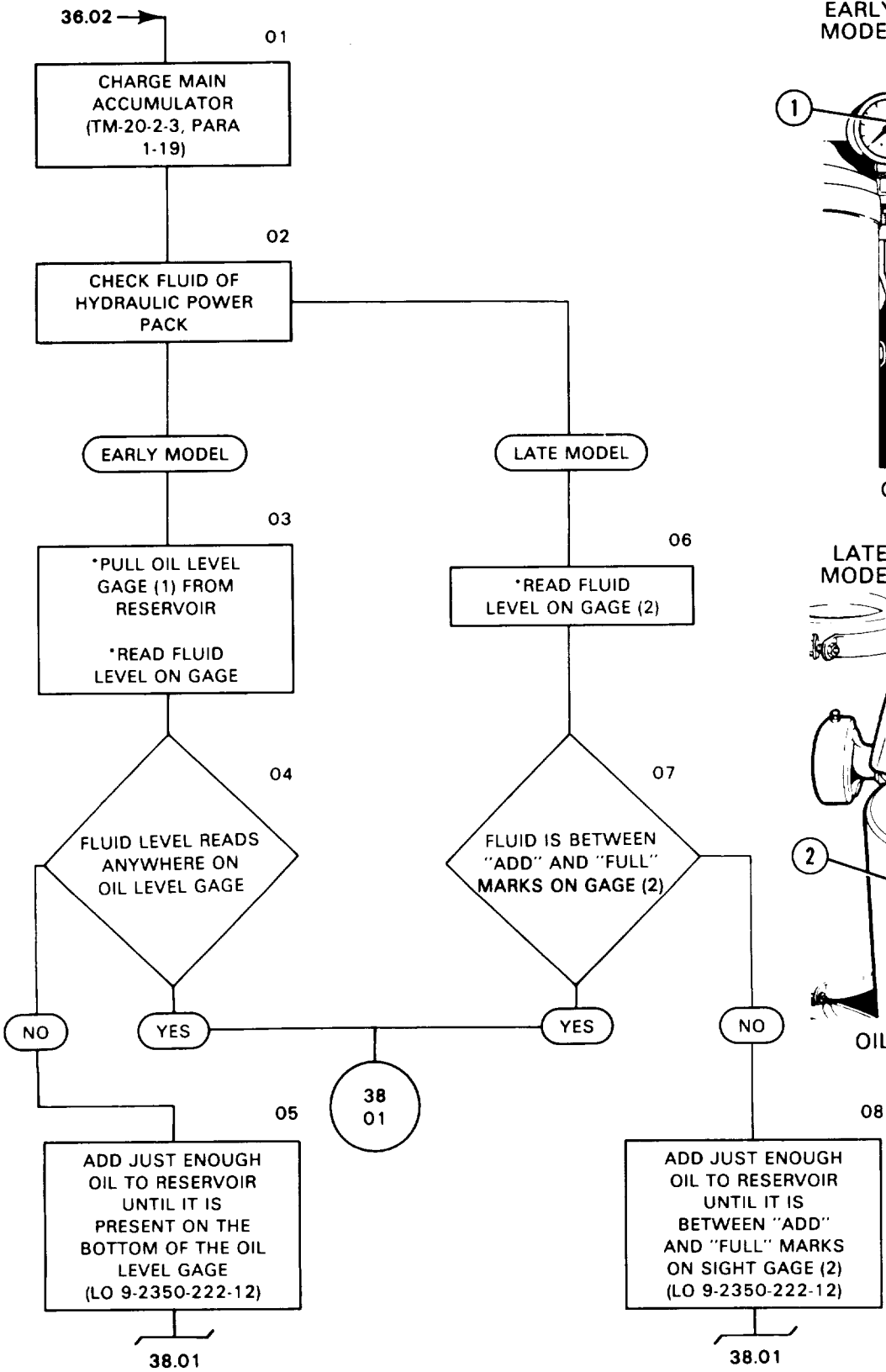

OIL LEVEL GAGE

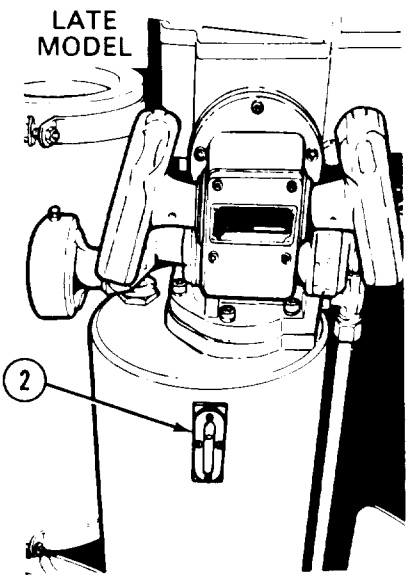

OIL LEVEL SIGHT GAGE

4-1. TURRET TRAVERSE TROUBLESHOOTING (SHEET 38 OF 75)

37.05 →
OR
37.08

01

CAUTION
TO PREVENT EQUIPMENT DAMAGE, BE SURE TO TURN OFF POWER BEFORE REMOVING COVERS, JACKS, PLUGS, OR RELAY CARDS, AND BEFORE MEASURING CONTINUITY OR RESISTANCE. AFTER MEASUREMENT, TURN POWER BACK ON.

02

NOTE
FOR USE OF MULTIMETER TO MEASURE VOLTAGE, CONTINUITY, AND RESISTANCE, REFER TO JPG

03

WARNING
CHECK OUTSIDE OF TANK AND SURROUNDING AREA FOR UNWARY PERSONNEL. MAKE SURE CREW MEMBERS ARE IN SAFE POSITIONS AND DRIVER HAS LOWERED HIS SEAT AND HAS HEAD DOWN.

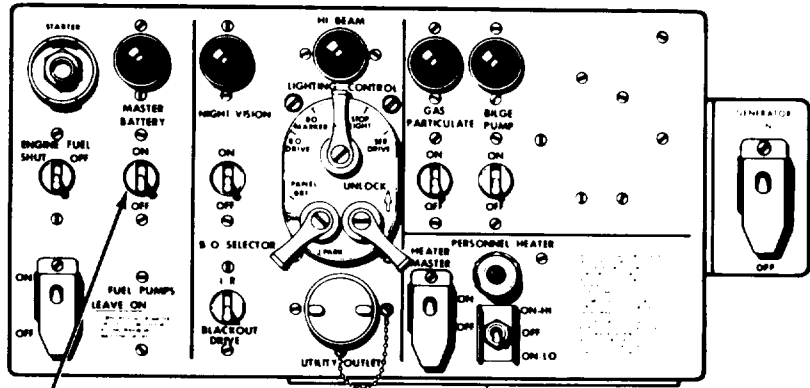

MASTER CONTROL PANEL

04

CAUTION
IF ELECTRIC DRIVE (DC) MOTOR RUNS CONTINUOUSLY, OR IF GAGE PRESSURE GOES HIGHER THAN 1500 PSI, OR IF PUMP MOTOR MAKES EXCESSIVE NOISE, TURN POWER OFF.

05

*SET VEHICLE 'MASTER BATTERY' SWITCH (1) TO 'ON'

39.01

4-1. TURRET TRAVERSE TROUBLESHOOTING (SHEET 39 OF 75)

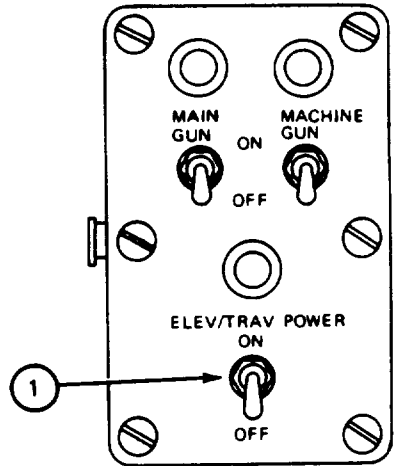
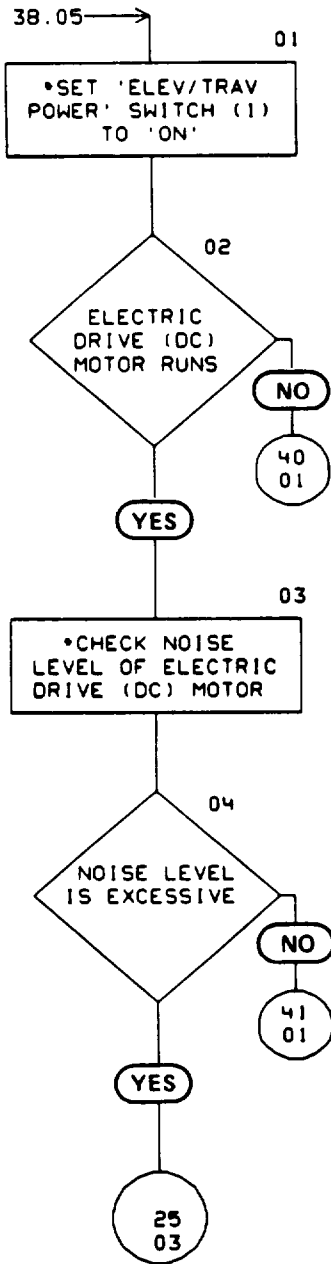

GUNNER'S CONTROL BOX

4-1. TURRET TRAVERSE TROUBLESHOOTING (SHEET 40 OF 75)

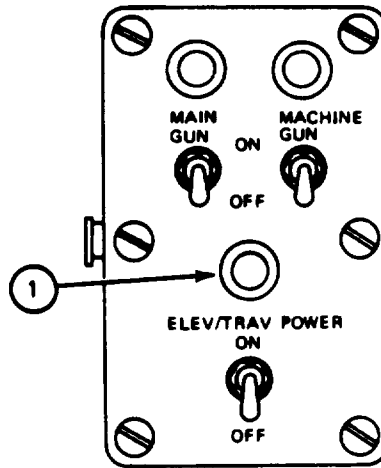
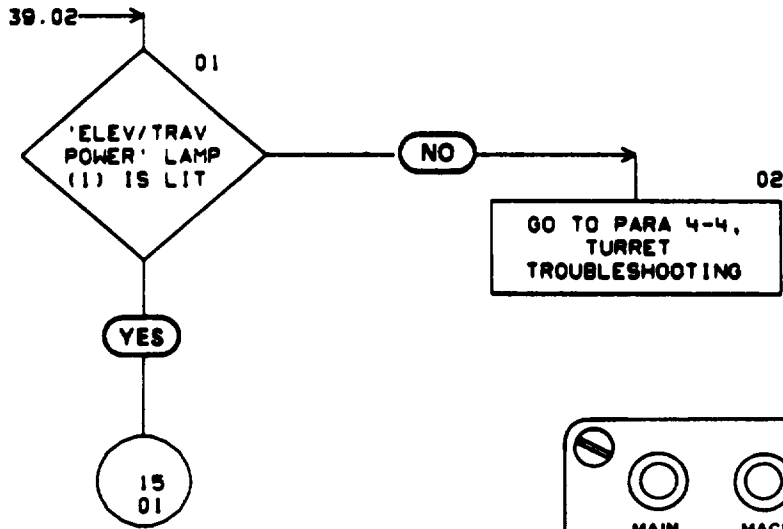

GUNNER'S CONTROL BOX

4-1. TURRET TRAVERSE TROUBLESHOOTING (SHEET 41 OF 75)

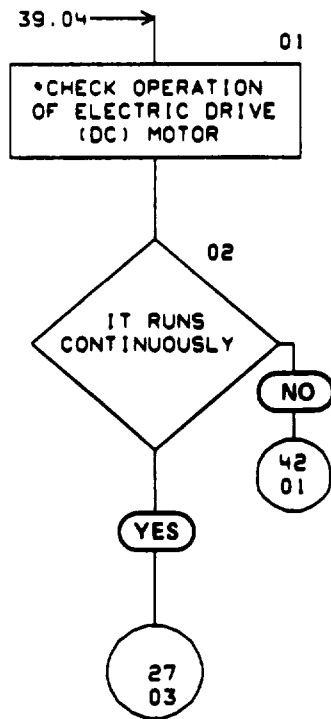

4-1. TURRET TRAVERSE TROUBLESHOOTING (SHEET 42 OF 75)

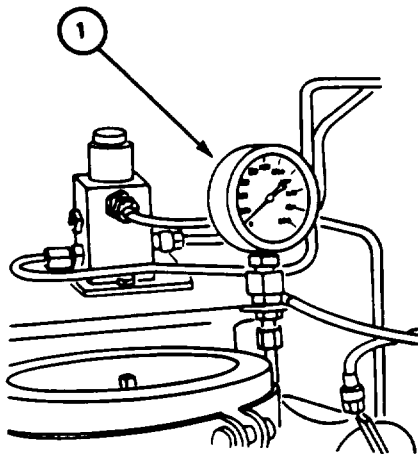
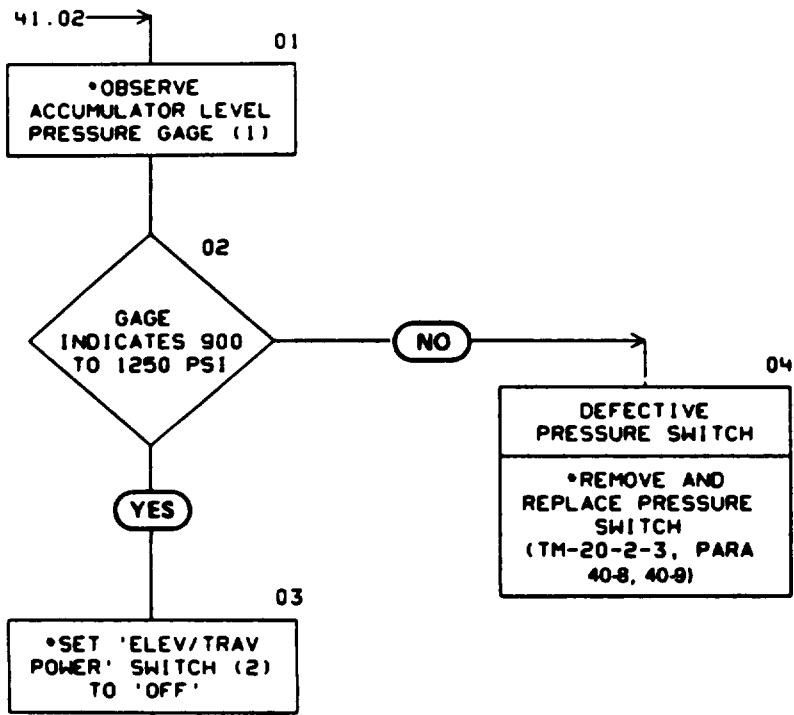

PRESSURE GAGE

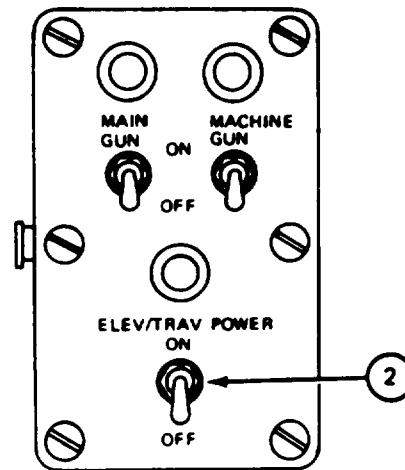

GUNNER'S CONTROL BOX

4-1. TURRET TRAVERSE TROUBLESHOOTING (SHEET 43 OF 75)

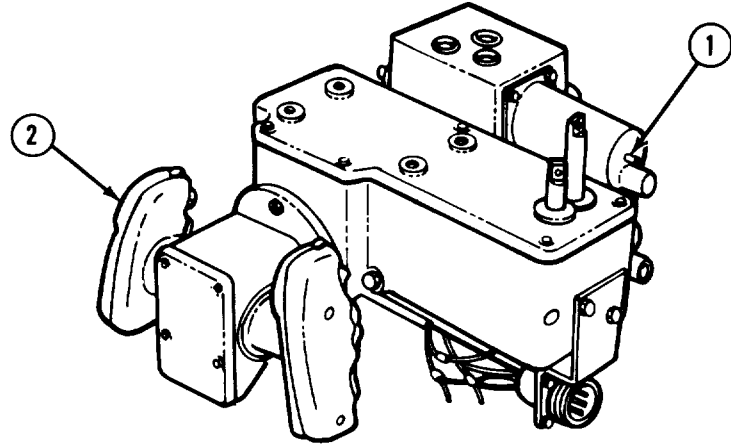
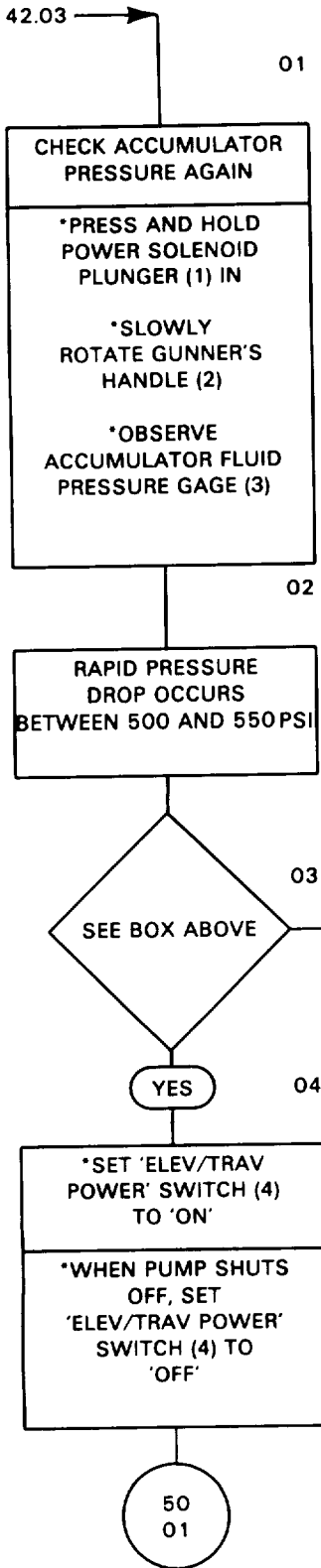

GUNNER'S CONTROL ASSEMBLY

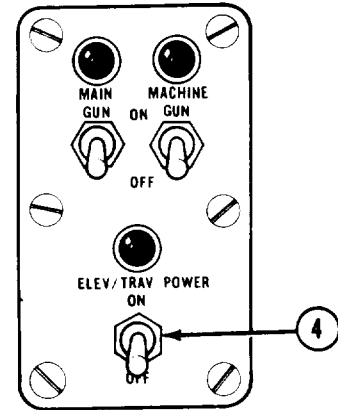

GUNNER'S CONTROL BOX

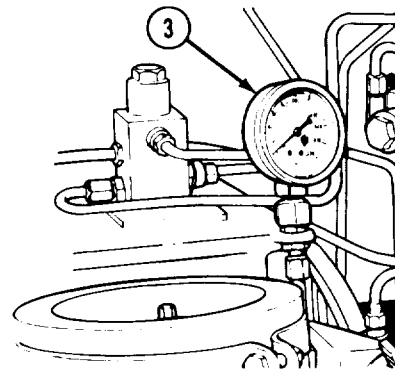

PRESSURE GAGE

4-1. TURRET TRAVERSE TROUBLESHOOTING (SHEET 44 OF 75)

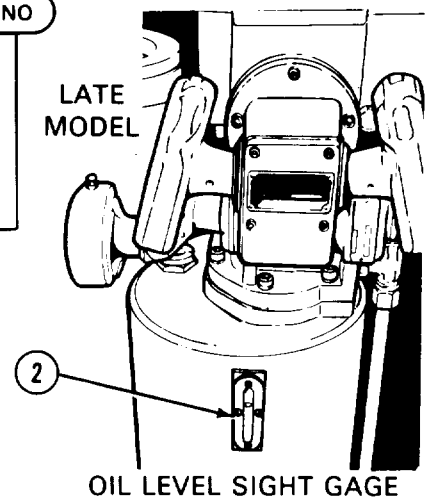
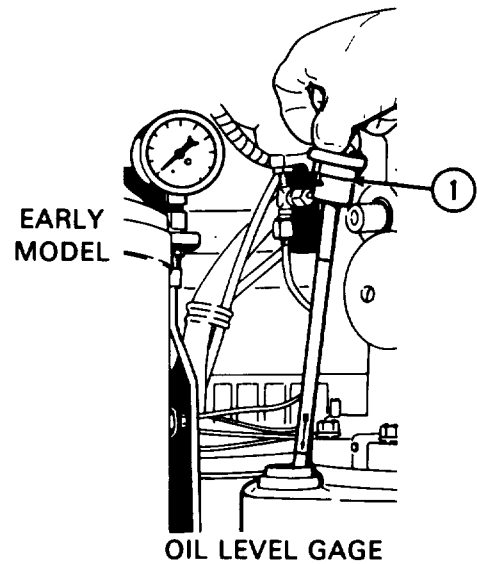
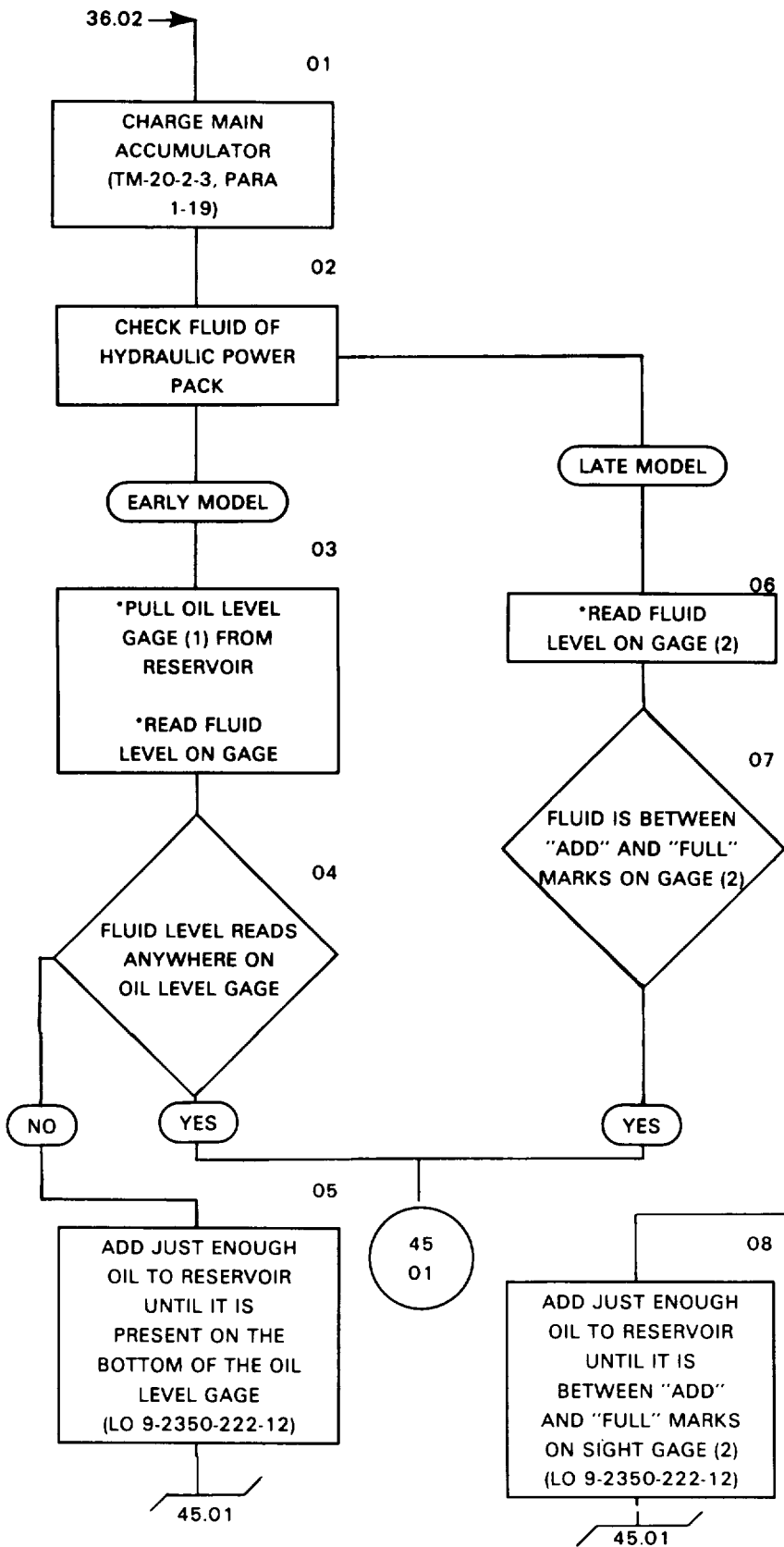

4-1. TURRET TRAVERSE TROUBLESHOOTING (SHEET 45 OF 75)

44.05
OR
44.08

01

CAUTION
TO PREVENT EQUIPMENT DAMAGE, BE SURE TO TURN OFF POWER BEFORE REMOVING COVERS, JACKS, PLUGS, OR RELAY CARDS, AND BEFORE MEASURING CONTINUITY OR RESISTANCE. AFTER MEASUREMENT, TURN POWER BACK ON.

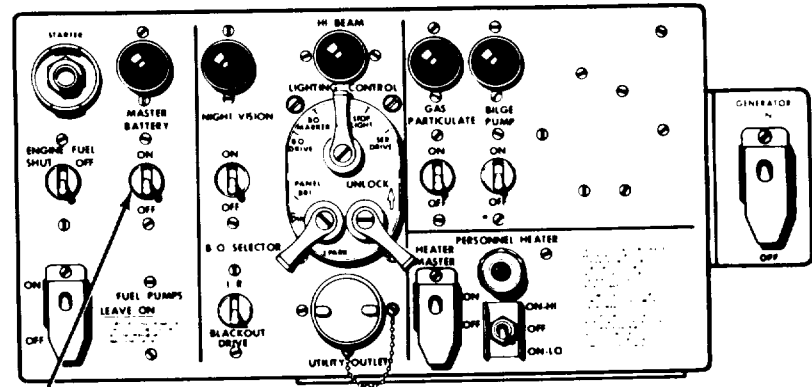

MASTER CONTROL PANEL

02

NOTE
FOR USE OF MULTIMETER TO MEASURE VOLTAGE, CONTINUITY, AND RESISTANCE, REFER TO JPG.

03

WARNING
CHECK OUTSIDE OF TANK AND SURROUNDING AREA FOR UNWARY PERSONNEL. MAKE SURE CREW MEMBERS ARE IN SAFE POSITIONS AND DRIVER HAS LOWERED HIS SEAT AND HAS HEAD DOWN.

04

CAUTION
IF ELECTRIC DRIVE (DC) MOTOR RUNS CONTINUOUSLY, OR IF GAGE PRESSURE GOES HIGHER THAN 1500 PSI, OR IF PUMP MOTOR MAKES EXCESSIVE NOISE, TURN POWER OFF.

05

*SET VEHICLE 'MASTER BATTERY' SWITCH (1) TO 'ON'

46.01

4-1. TURRET TRAVERSE TROUBLESHOOTING (SHEET 46 OF 75)

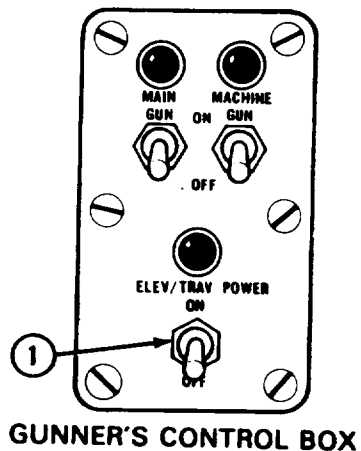
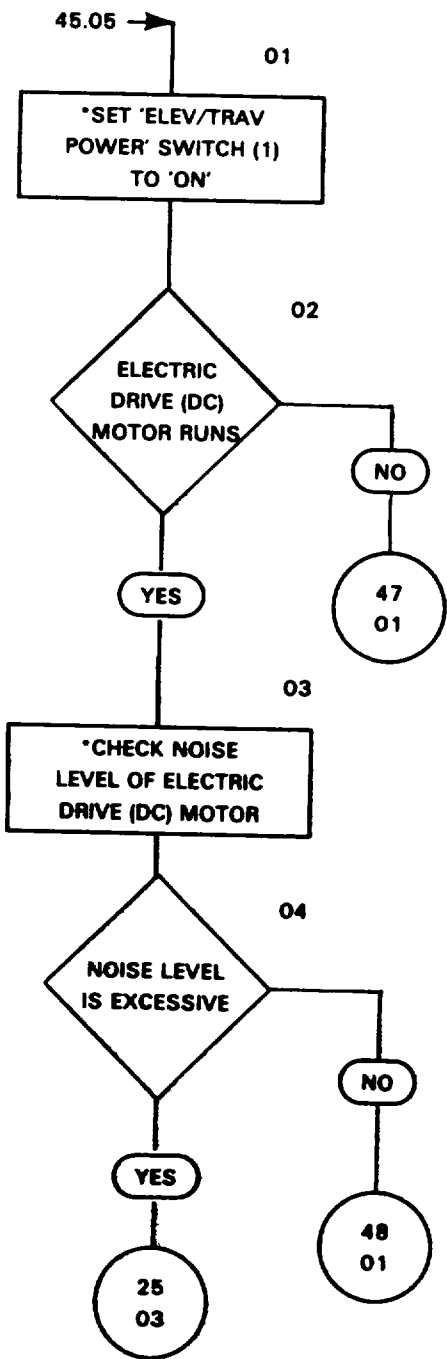

4-1. TURRET TRAVERSE TROUBLESHOOTING (SHEET 47 OF 75)

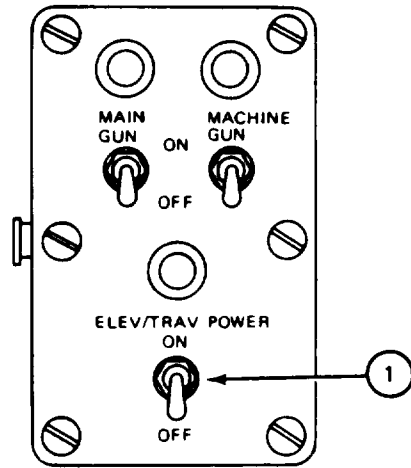
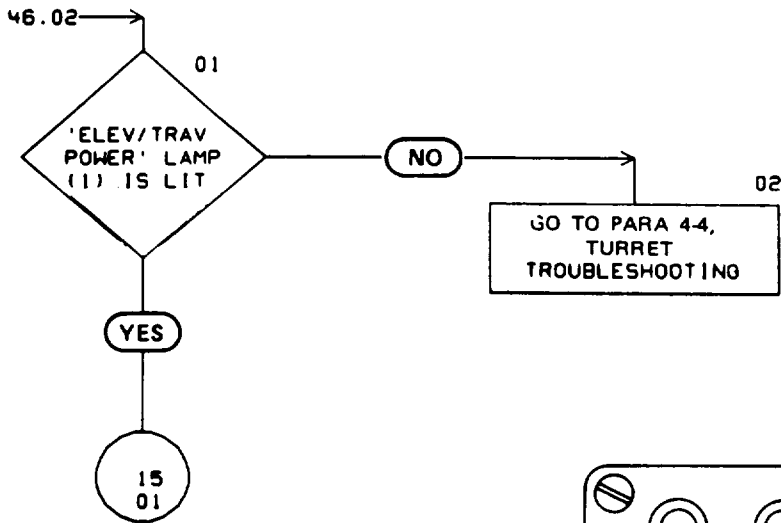

GUNNER'S CONTROL BOX

4-1. TURRET TRAVERSE TROUBLESHOOTING (SHEET 48 OF 75)

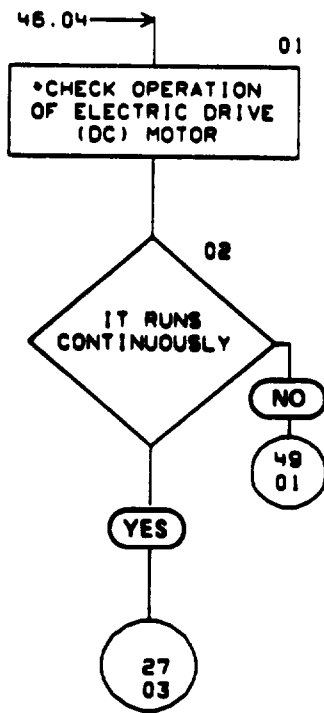

4-1. TURRET TRAVERSE TROUBLESHOOTING (SHEET 49 OF 75)

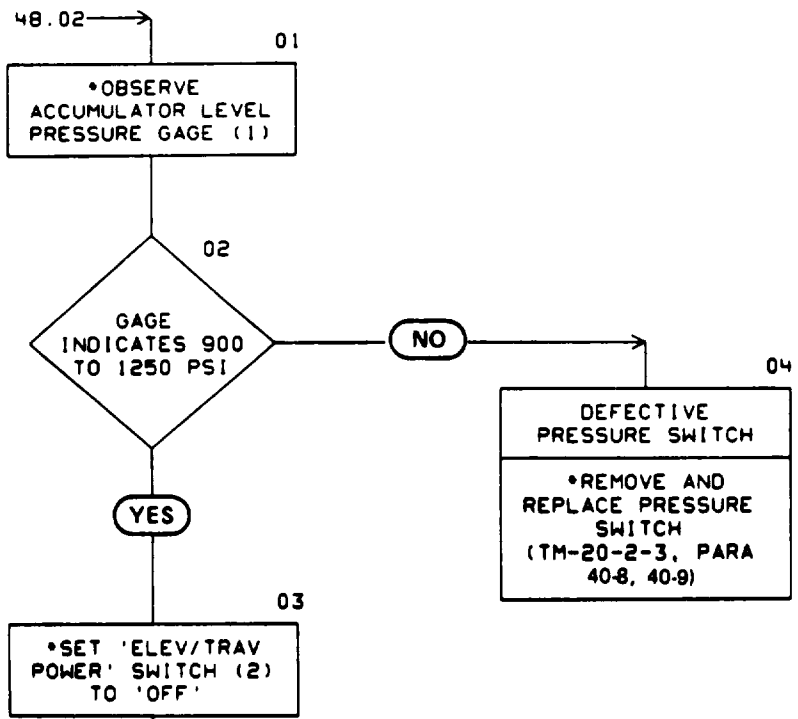

50
01

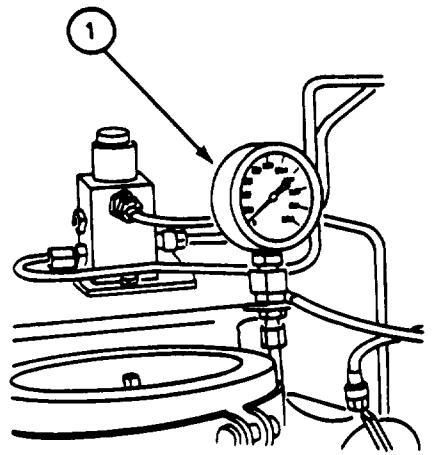

PRESSURE GAGE

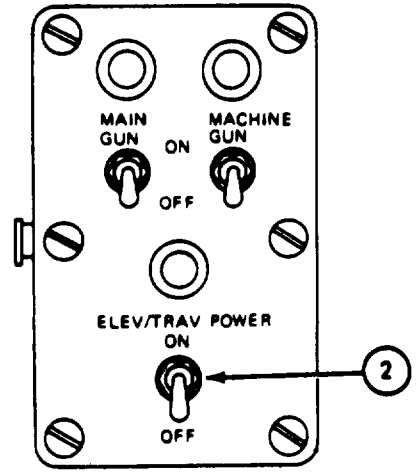

GUNNER'S CONTROL BOX

4-1. TURRET TRAVERSE TROUBLESHOOTING (SHEET 50 OF 75)

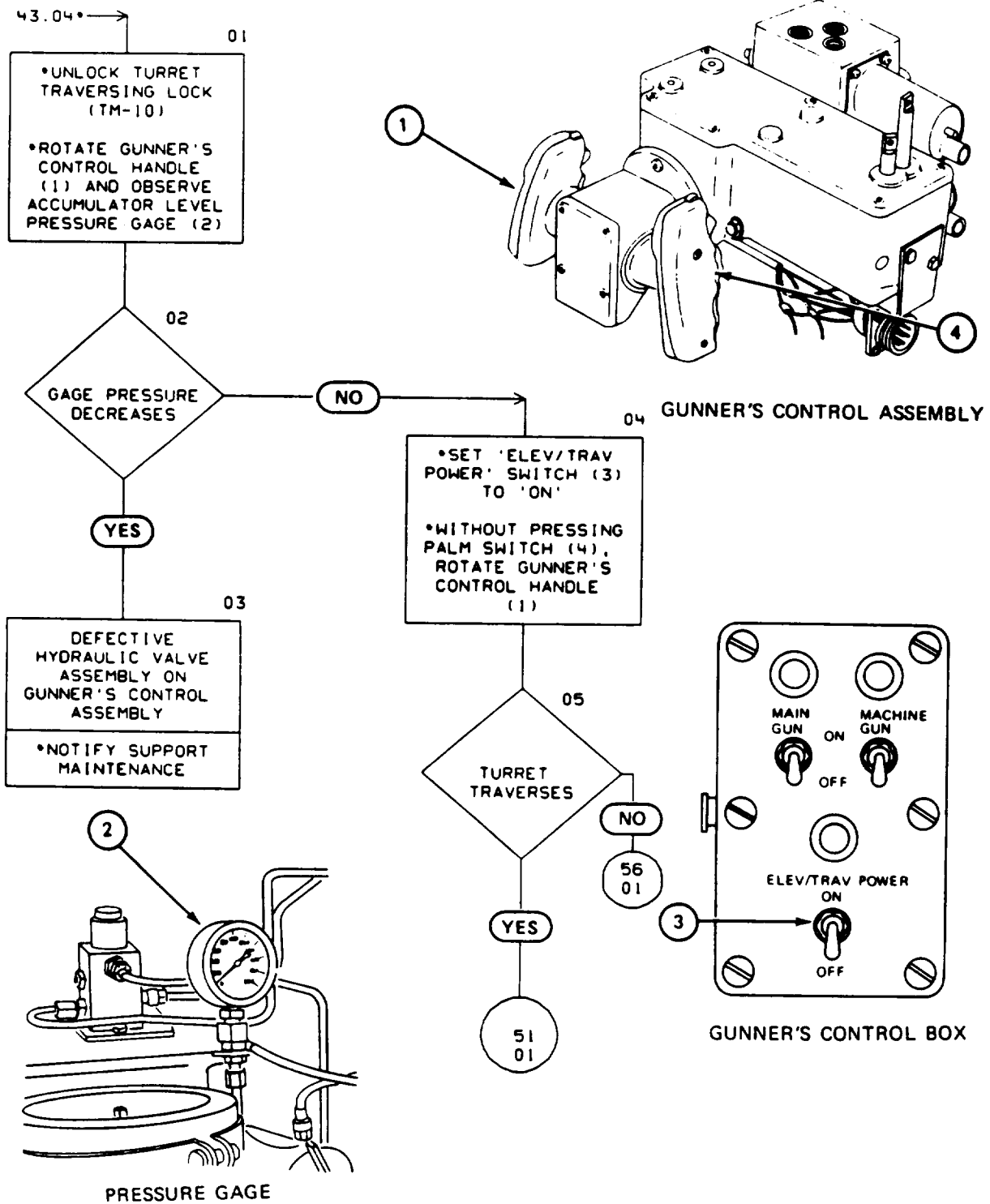

4-1. TURRET TRAVERSE TROUBLESHOOTING (SHEET 51 OF 75)

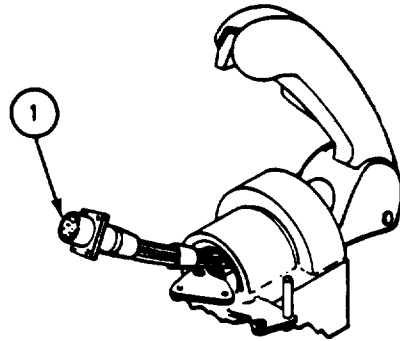
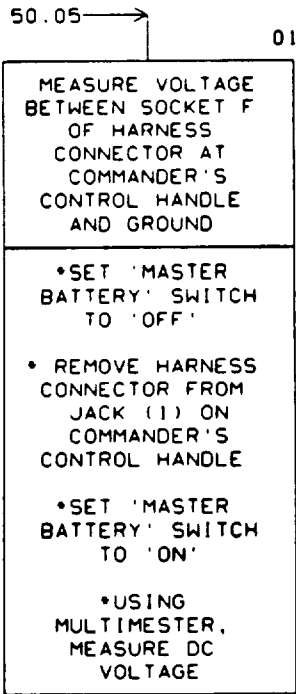

COMMANDER'S CONTROL HANDLE

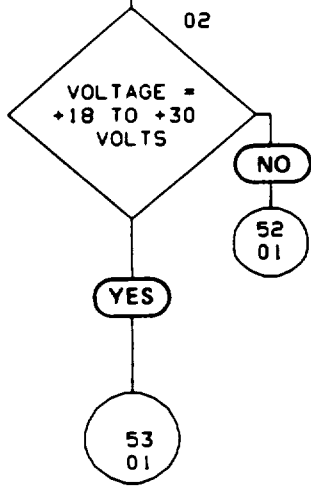

4-1. TURRET TRAVERSE TROUBLESHOOTING (SHEET 52 OF 75)

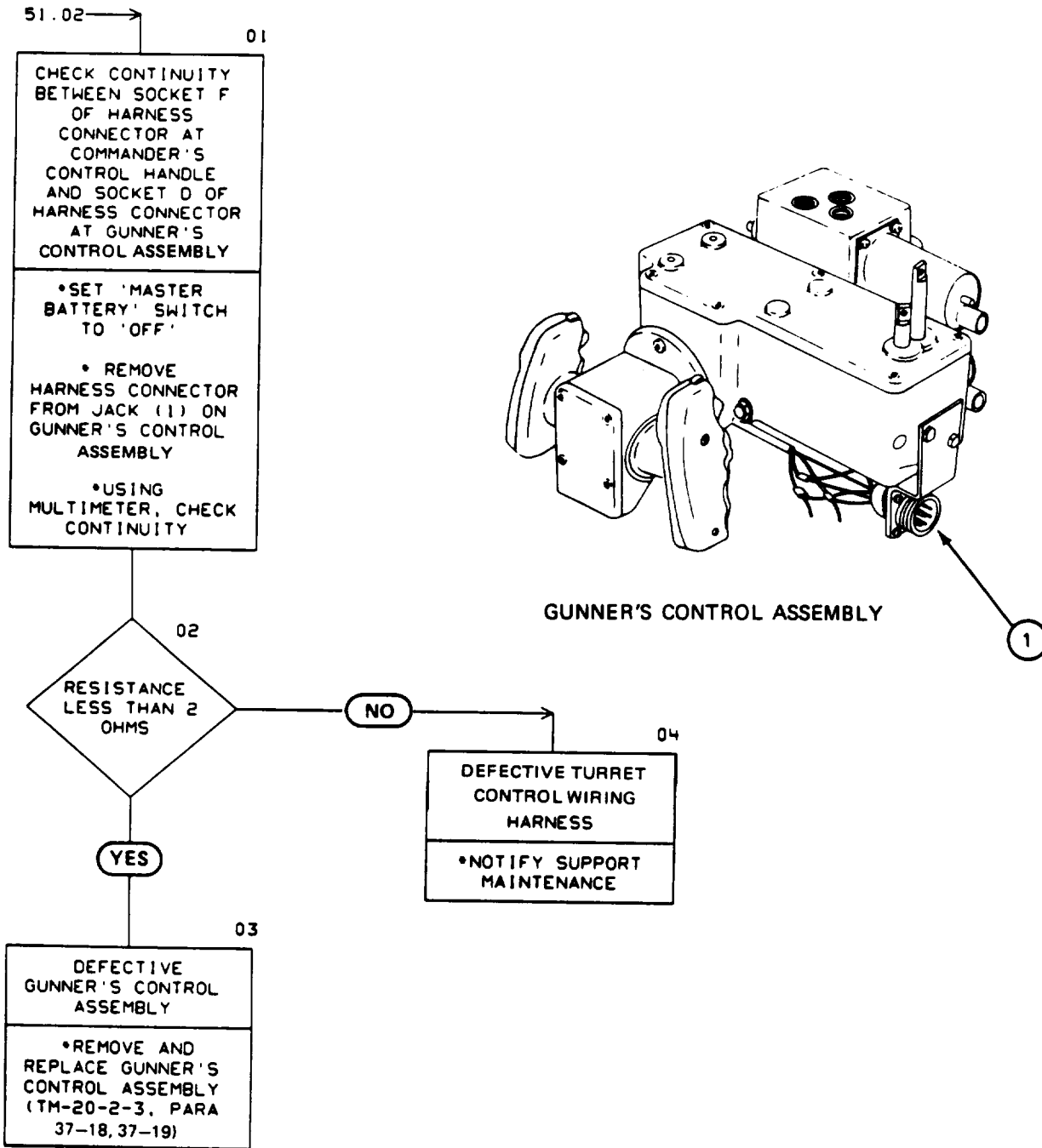

4-1. TURRET TRAVERSE TROUBLESHOOTING (SHEET 53 OF 75)

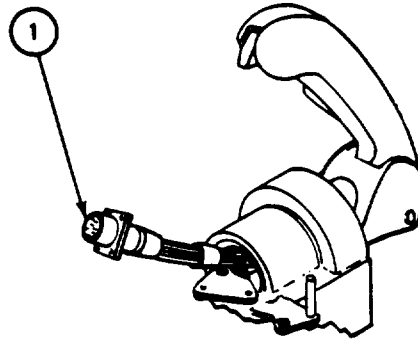
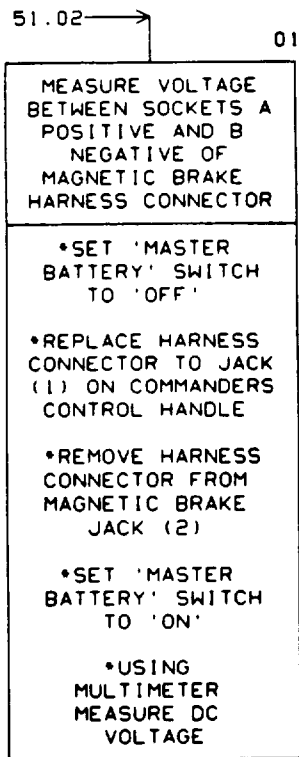

COMMANDER'S CONTROL HANDLE

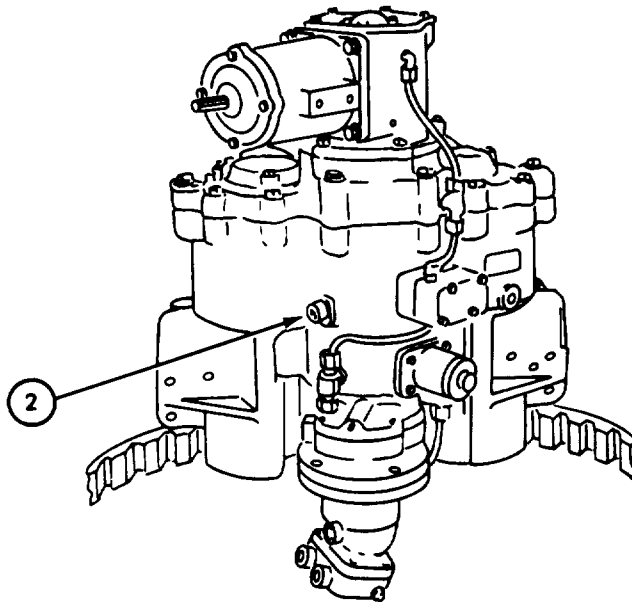
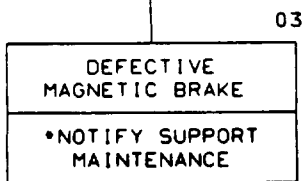
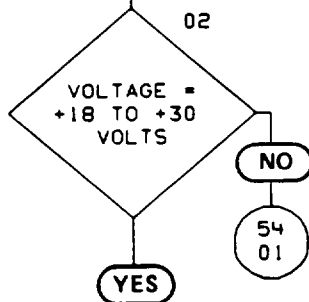

TRAVERSE MECHANISM ASSEMBLY

4-1. TURRET TRAVERSE TROUBLESHOOTING (SHEET 54 OF 75)

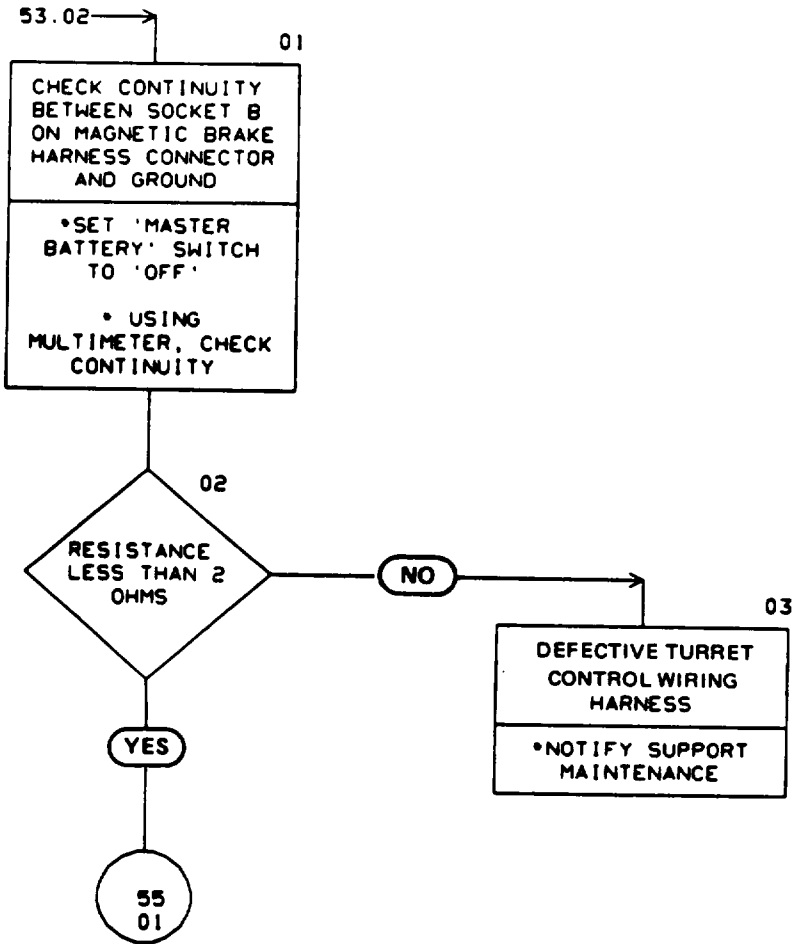

4-1. TURRET TRAVERSE TROUBLESHOOTING (SHEET 55 OF 75)

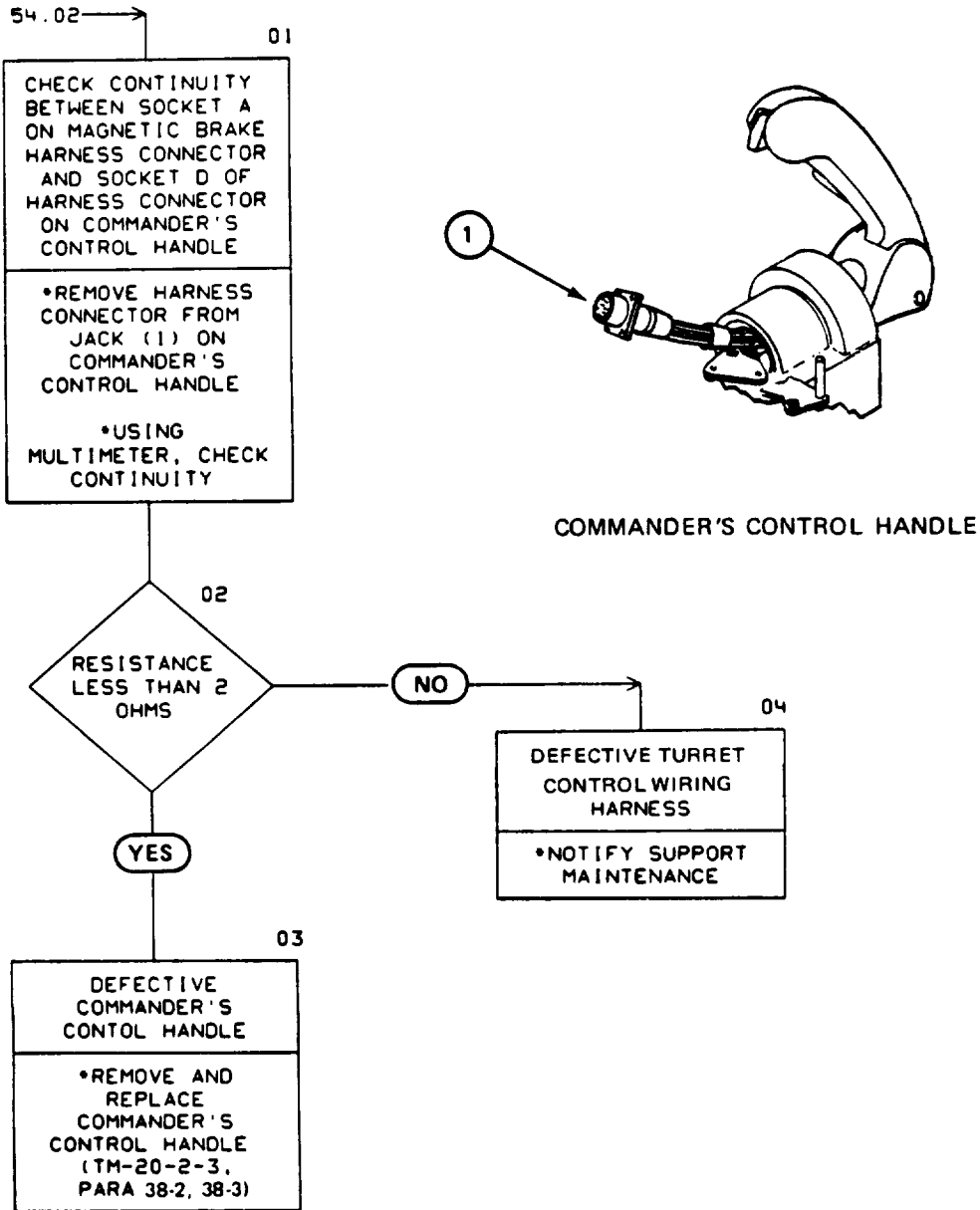

4-1. TURRET TRAVERSE TROUBLESHOOTING (SHEET 56 OF 75)

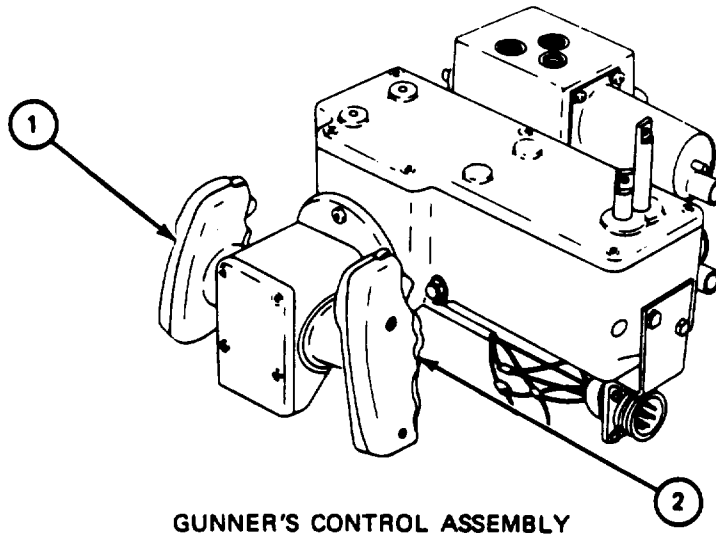
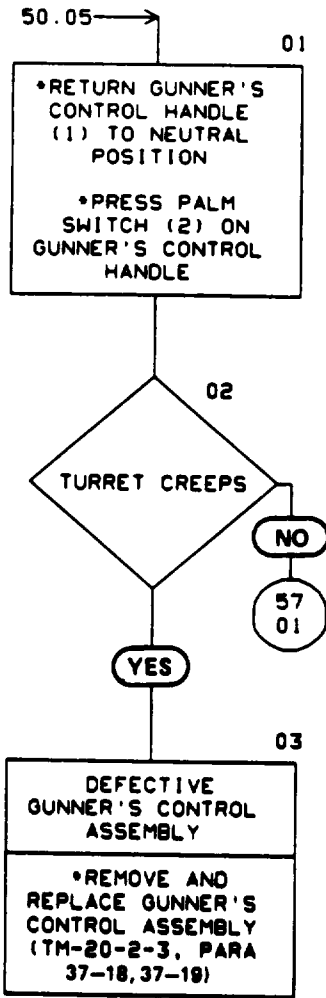

4-1. TURRET TRAVERSE TROUBLESHOOTING (SHEET 57 OF 75)

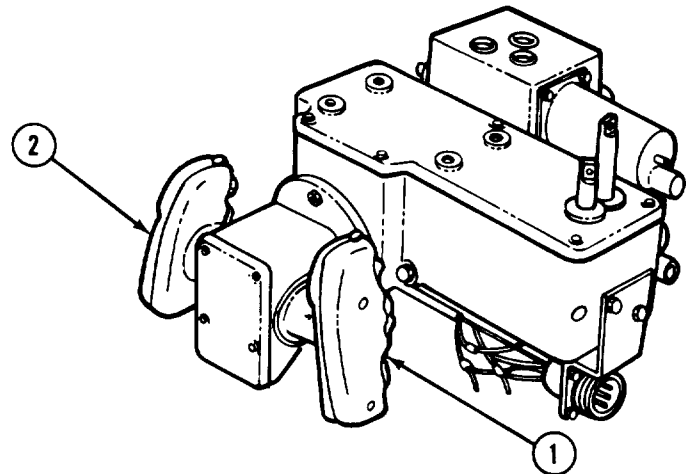
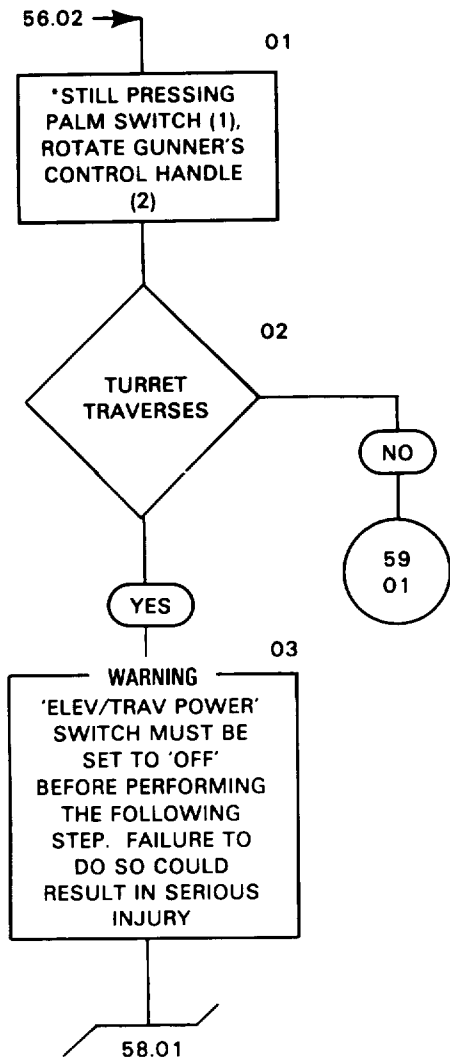

GUNNER'S CONTROL ASSEMBLY

4-1. TURRET TRAVERSE TROUBLESHOOTING (SHEET 58 OF 75)

57.03 → 01

CHECK NO-BACK ASSEMBLY

CAUTION
TO PREVENT UNNECESSARY WEAR AND/OR DAMAGE TO MAGNETIC BRAKE, DO NOT RELEASE PALM SWITCH WHILE TRAVERSING TURRET.

*HAVE DRIVER SET 'MASTER BATTERY' SWITCH (1) TO 'ON'

*SET 'ELEV/TRAV POWER' SWITCH (2) TO 'ON'

*PRESS PALM SWITCH (3) ON COMMANDER'S CONTROL HANDLE AND ROTATE TURRET AT HALF SPEED TO THE LEFT AND THEN TO THE RIGHT

*OBSERVE NO-BACK SPLINED INPUT SHAFT (4) FOR ROTATION

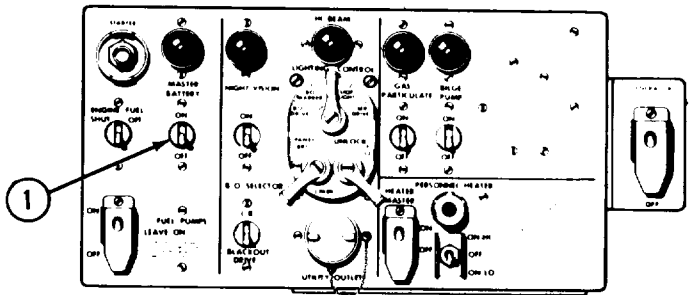

MASTER CONTROL PANEL

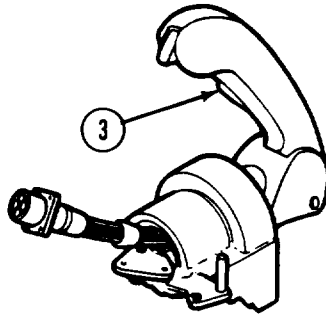

COMMANDER'S CONTROL HANDLE

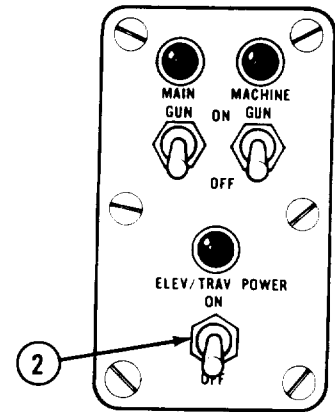

GUNNER'S CONTROL BOX

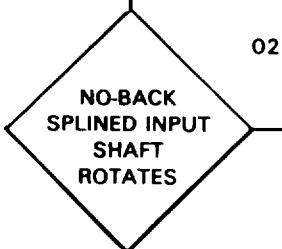

03

DEFECTIVE NO-BACK ASSEMBLY

*REMOVE AND REPLACE NO-BACK ASSEMBLY (TM-20-2-3, PARA 48-2, 48-3)

*INSTALL HAND TRAVERSING DRIVE ASSEMBLY (TM-20-2-3, PARA 50-2, 50-3)

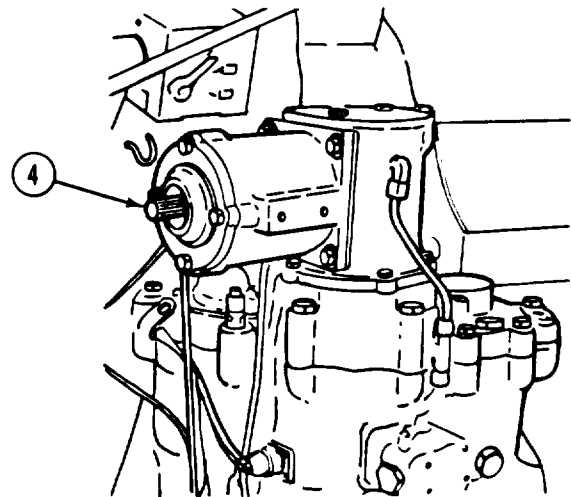

4-1. TURRET TRAVERSE TROUBLESHOOTING (SHEET 59 OF 75)

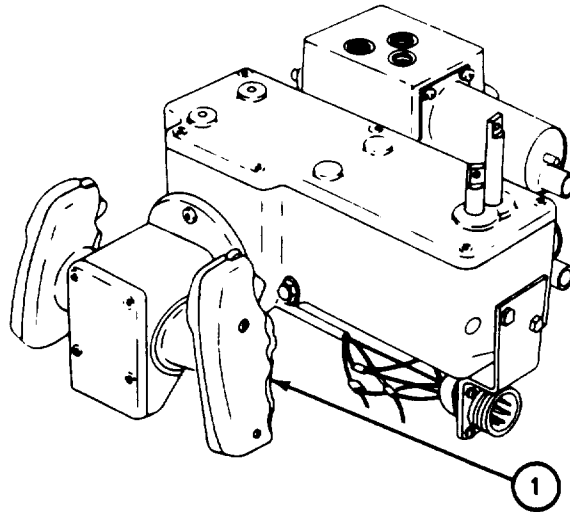
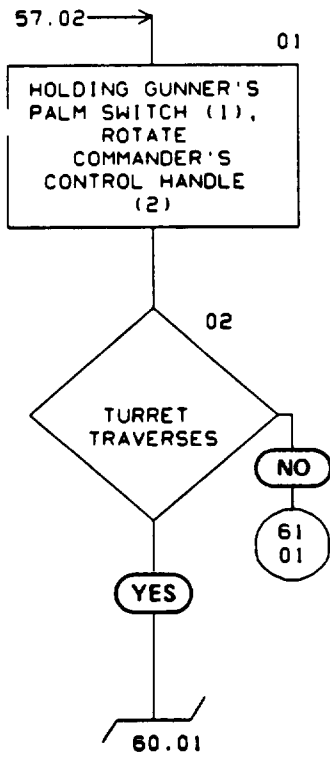

GUNNER'S CONTROL ASSEMBLY

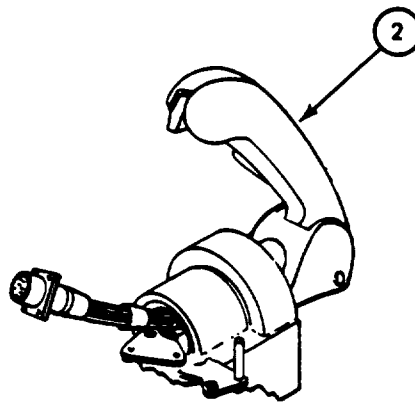

COMMANDER'S CONTROL HANDLE

4-1. TURRET TRAVERSE TROUBLESHOOTING (SHEET 60 OF 75)

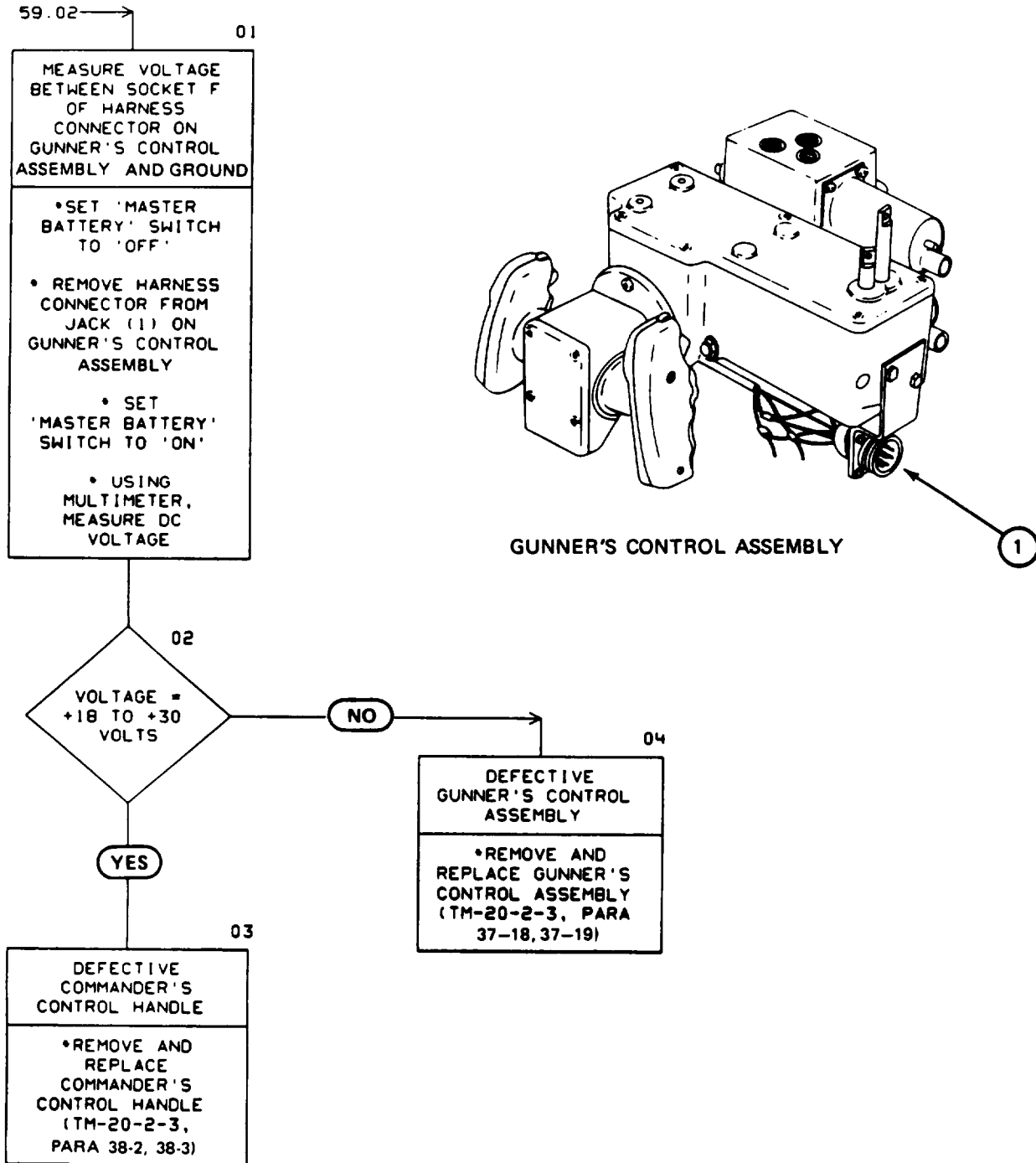

4-1. TURRET TRAVERSE TROUBLESHOOTING (SHEET 61 OF 75)

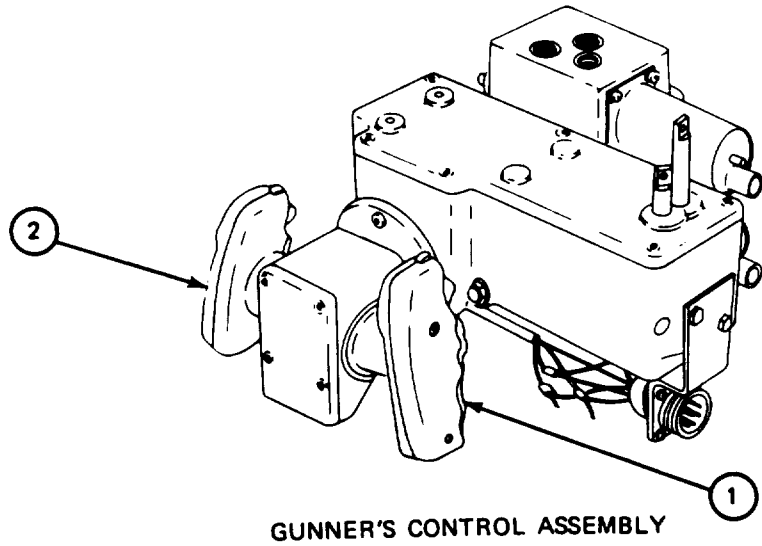
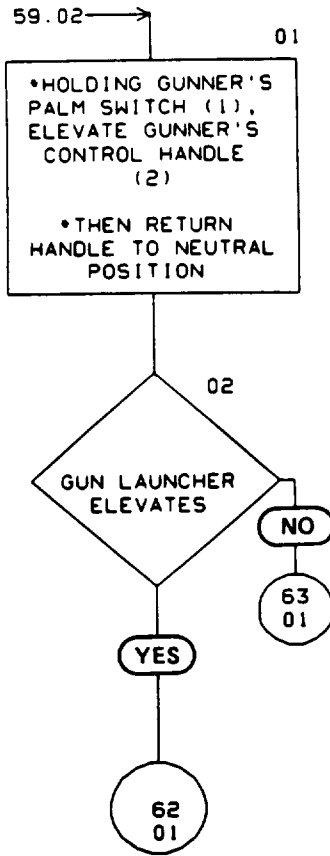

4-1. TURRET TRAVERSE TROUBLESHOOTING (SHEET 62 OF 75)

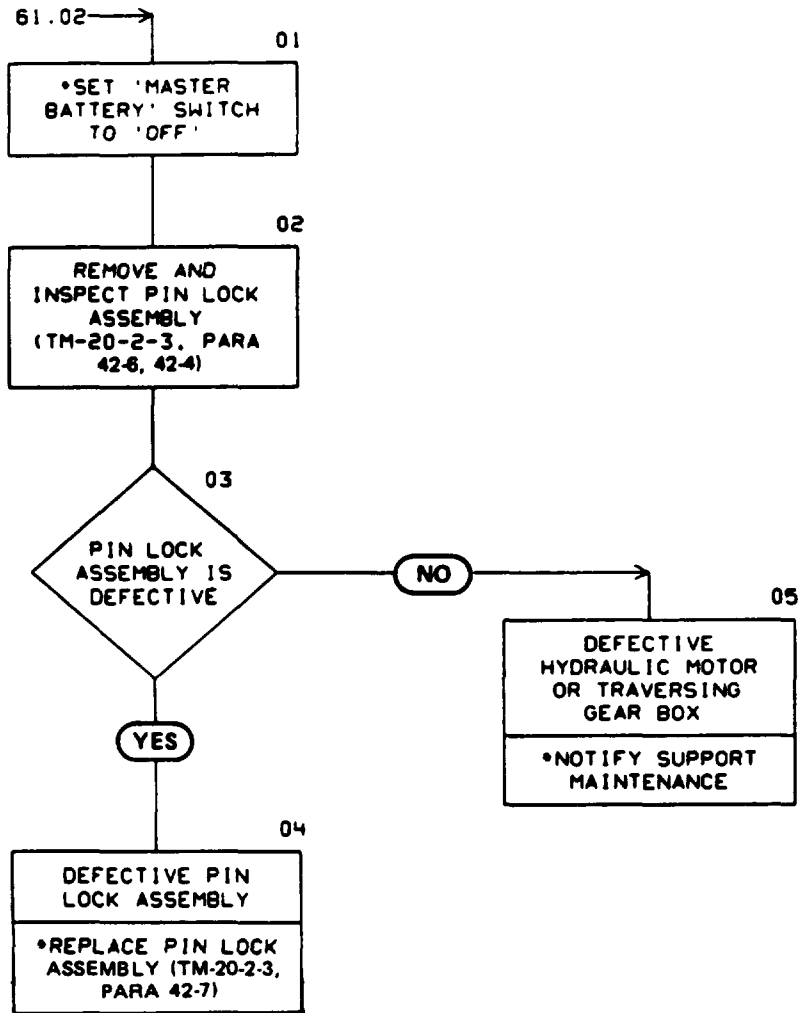

4.1. TURRET TRAVERSE TROUBLESHOOTING (SHEET 63 OF 75)

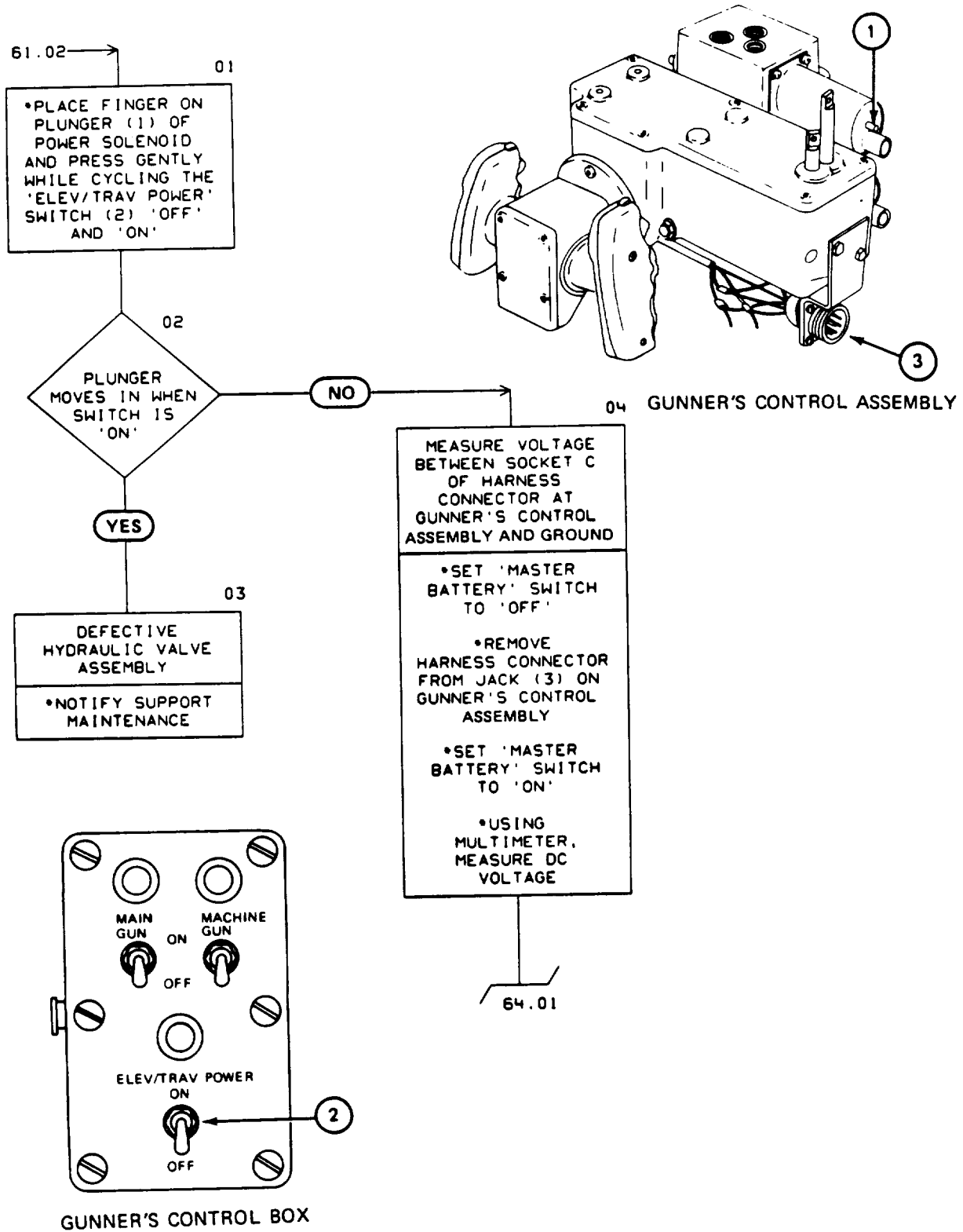

4-1. TURRET TRAVERSE TROUBLESHOOTING (SHEET 64 OF 75)

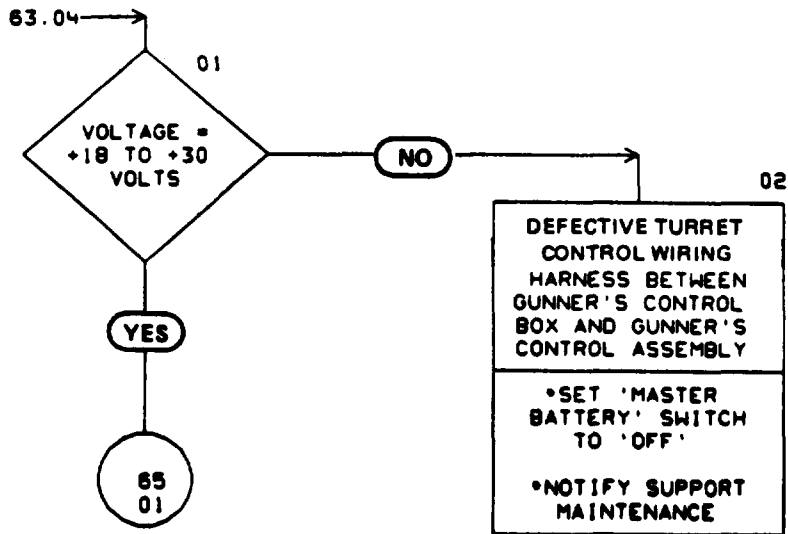

4-1. TURRET TRAVERSE TROUBLESHOOTING (SHEET 65 OF 75)

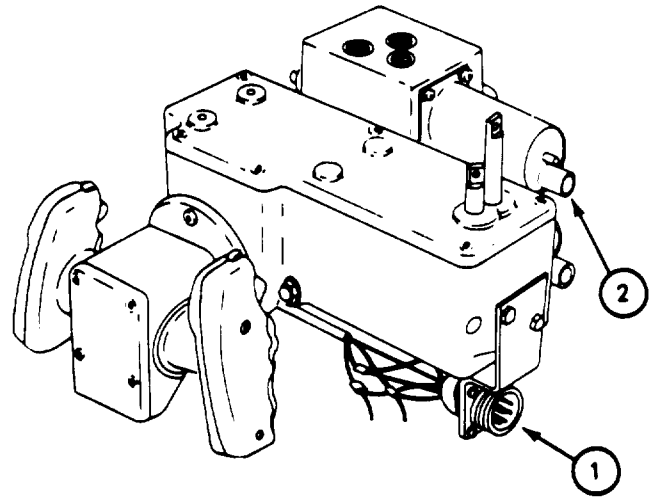
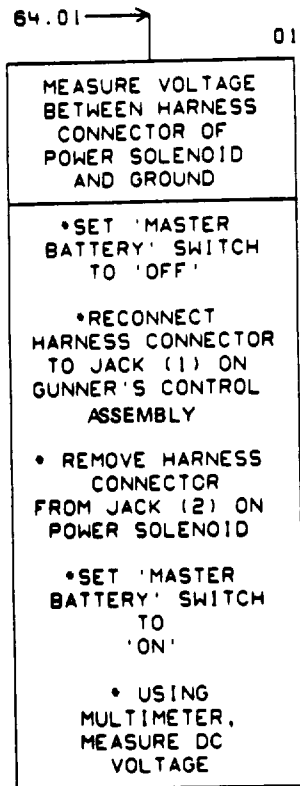

GUNNER'S CONTROL ASSEMBLY

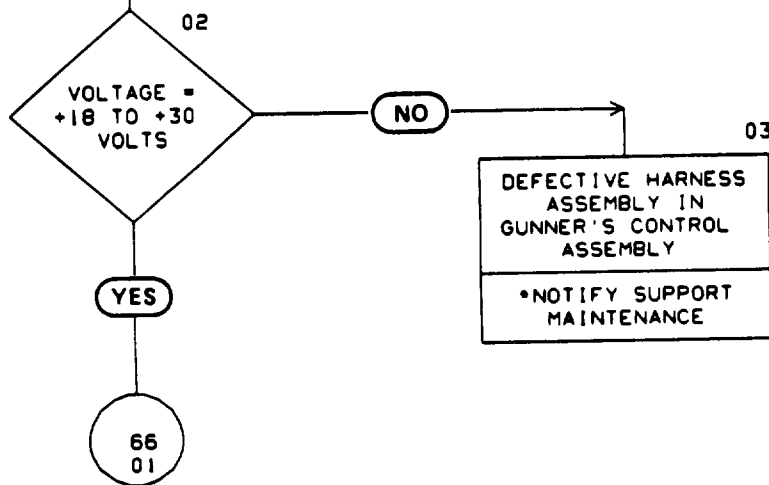

4-1. TURRET TRAVERSE TROUBLESHOOTING (SHEET 66 OF 75)

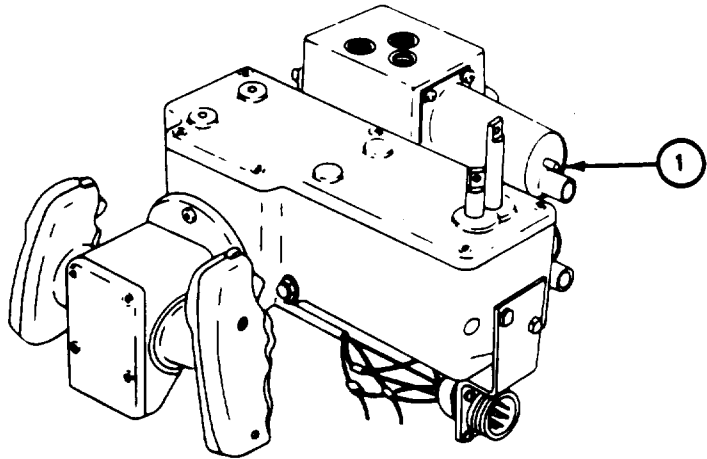
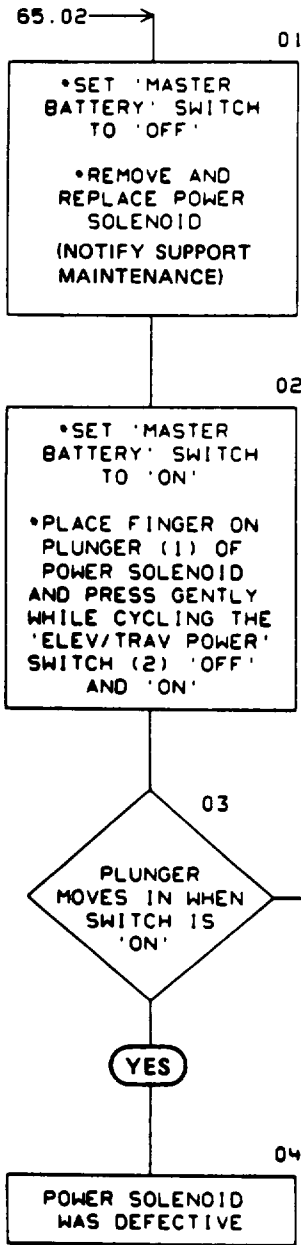

GUNNER'S CONTROL ASSEMBLY

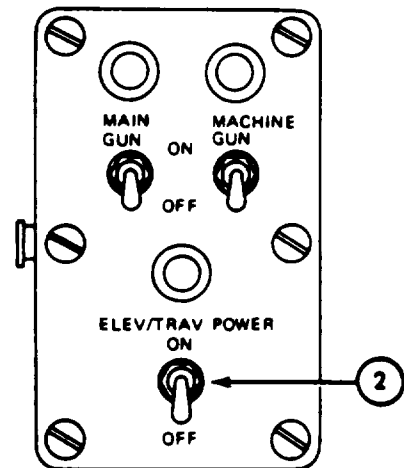

GUNNER'S CONTROL BOX

4-1. TURRET TRAVERSE TROUBLESHOOTING (SHEET 67 OF 75)

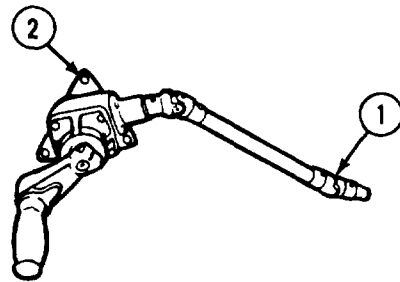
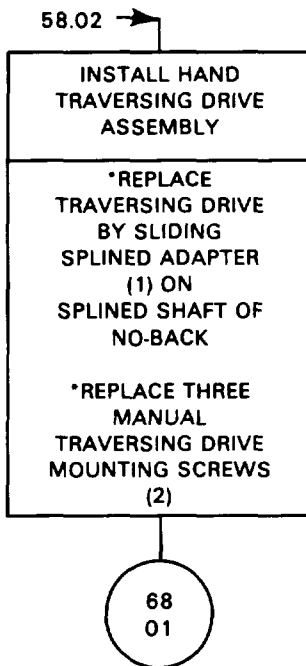

HAND TRAVERSING ASSEMBLY

4-1. TURRET TRAVERSE TROUBLESHOOTING (SHEET 68 OF 75)

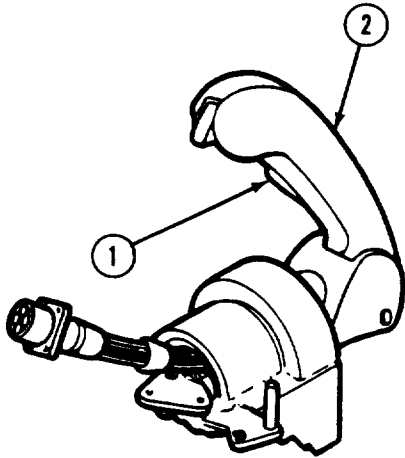
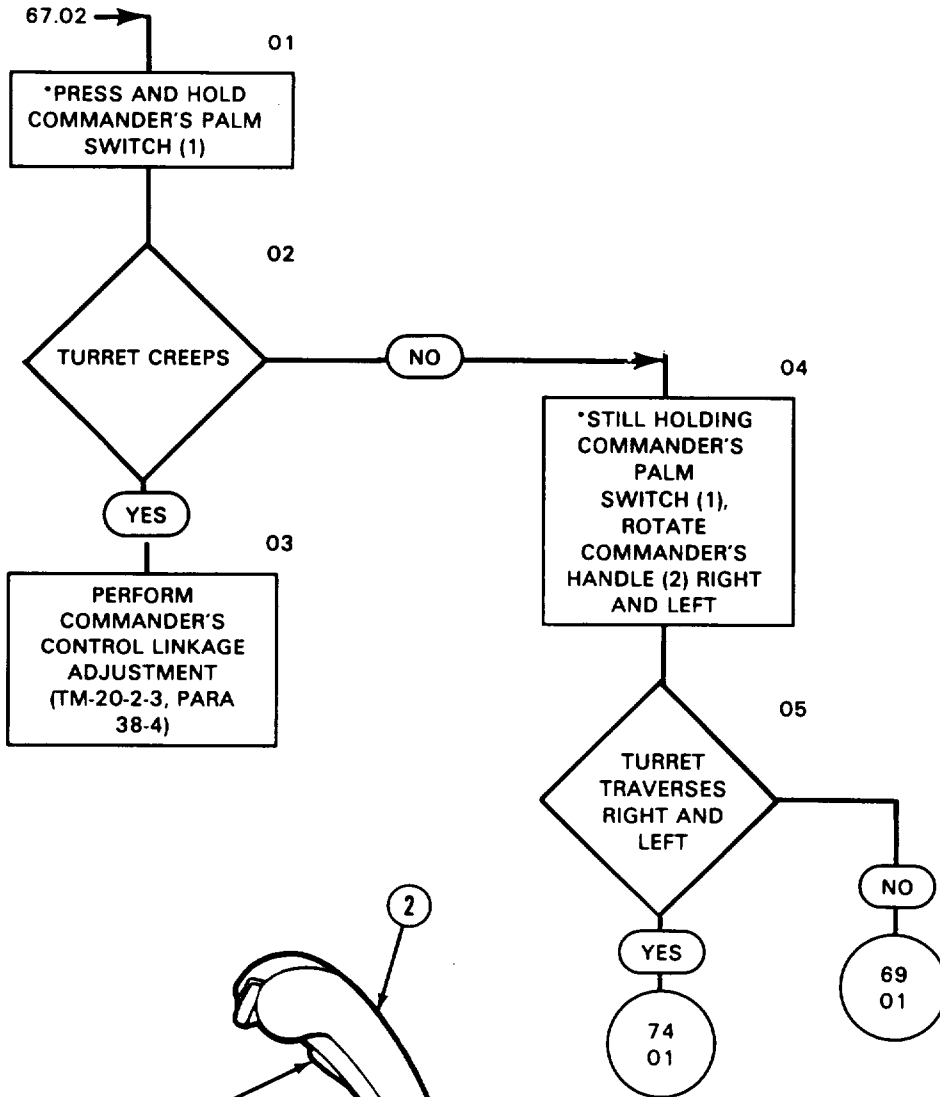

COMMANDER'S CONTROL HANDLE

4.1. TURRET TRAVERSE TROUBLESHOOTING (SHEET 69 OF 75)

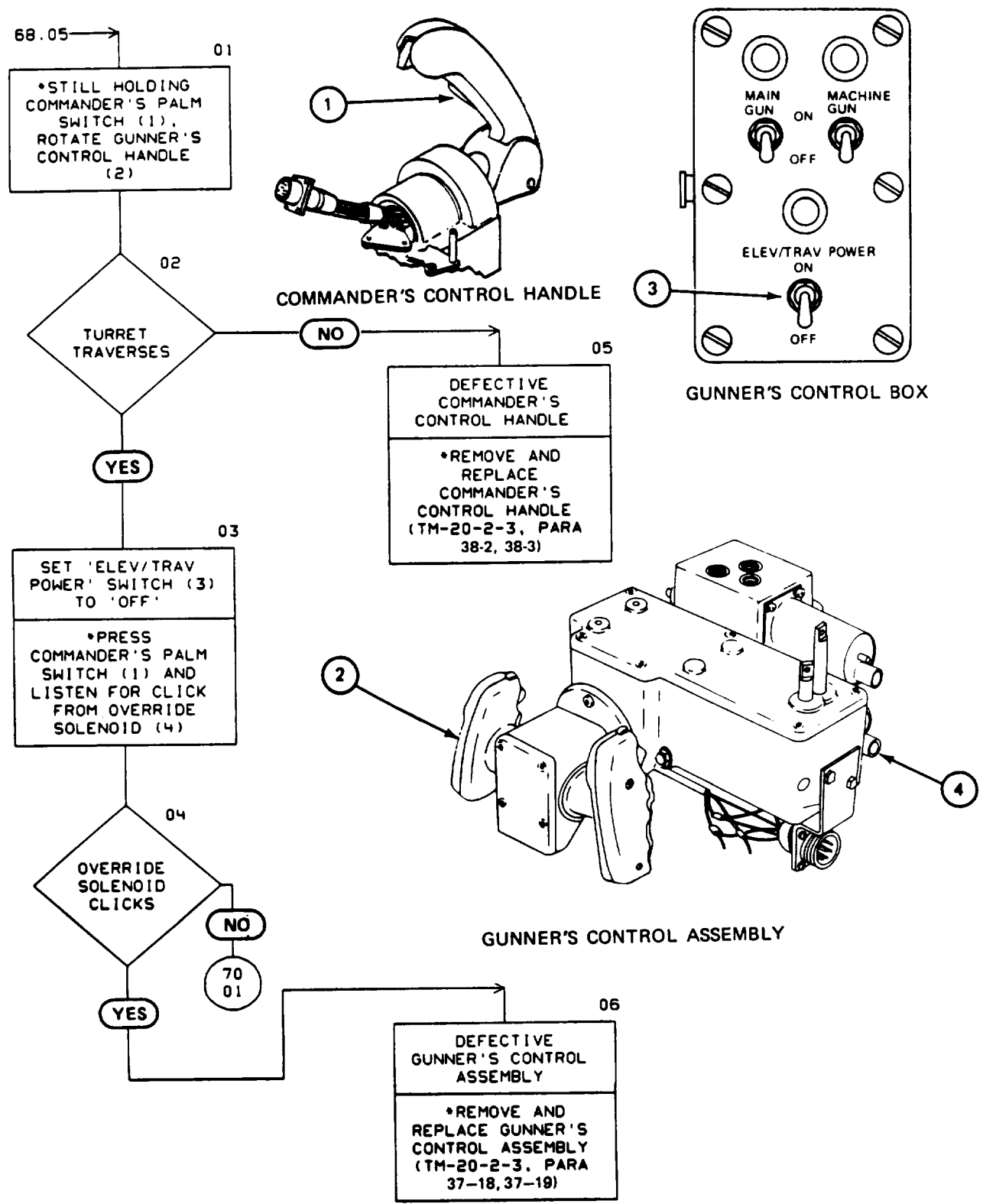

4-1. TURRET TRAVERSE TROUBLESHOOTING (SHEET 70 OF 75)

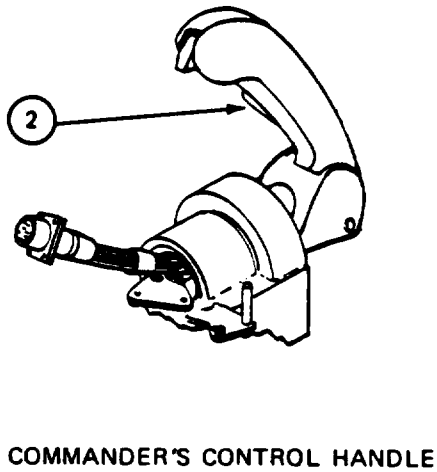
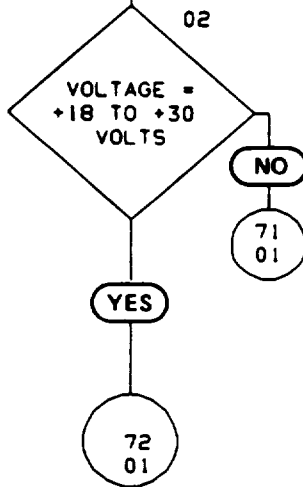
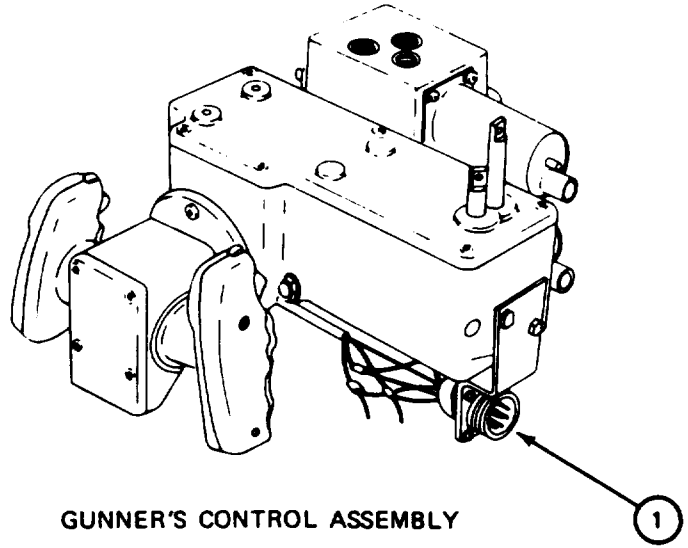
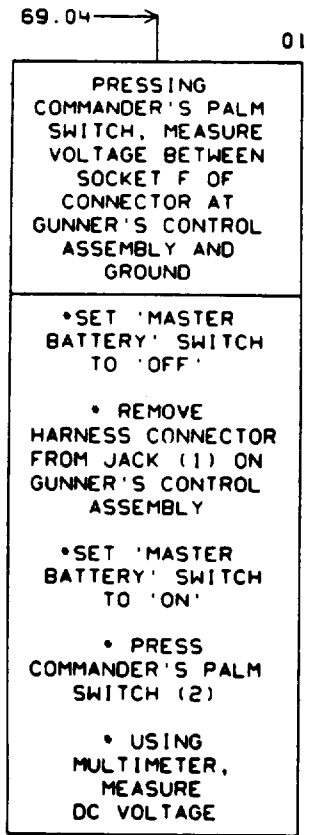

4-1. TURRET TRAVERSE TROUBLESHOOTING (SHEET 71 OF 75)

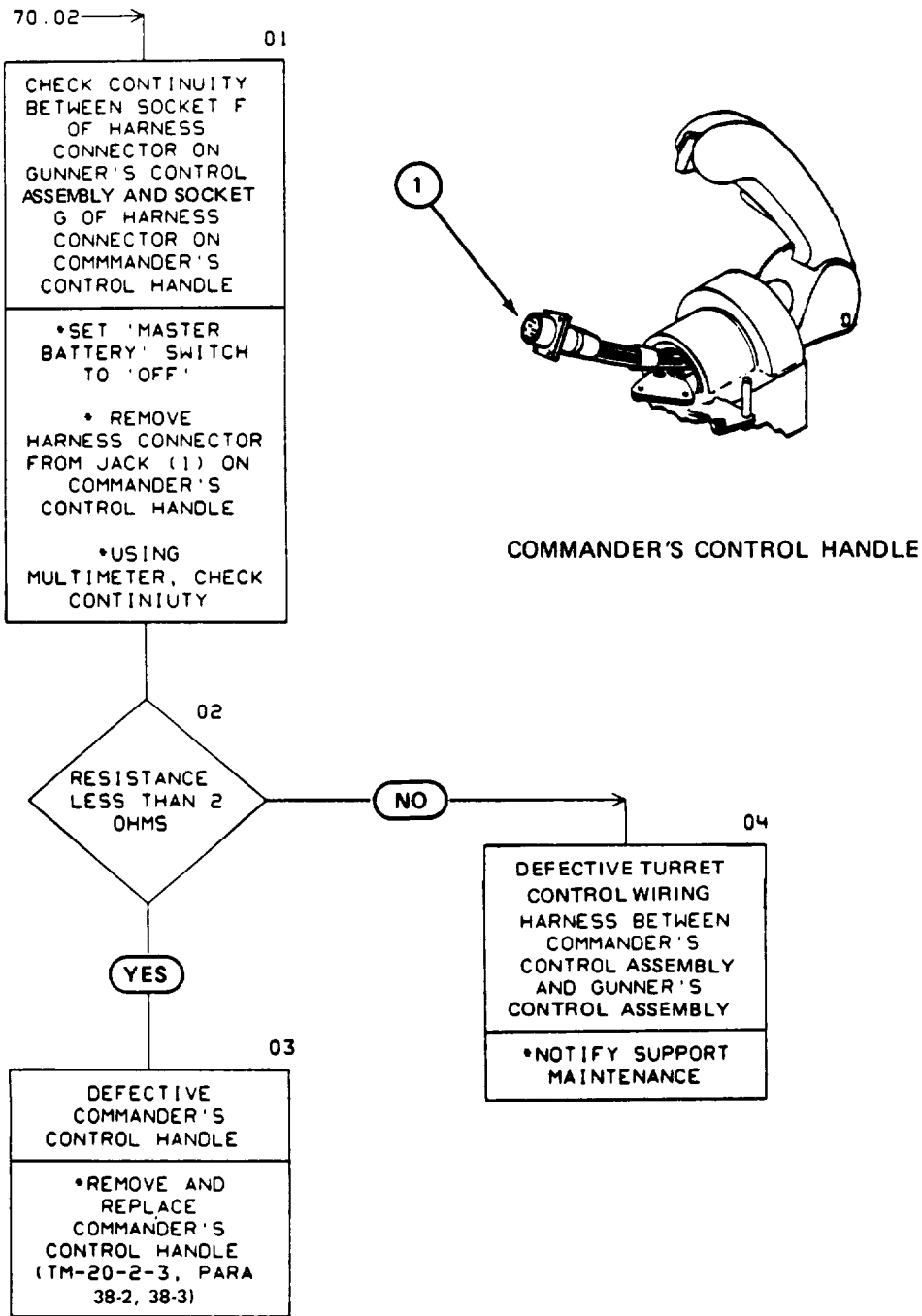

4-1. TURRET TRAVERSE TROUBLESHOOTING (SHEET 72 OF 75)

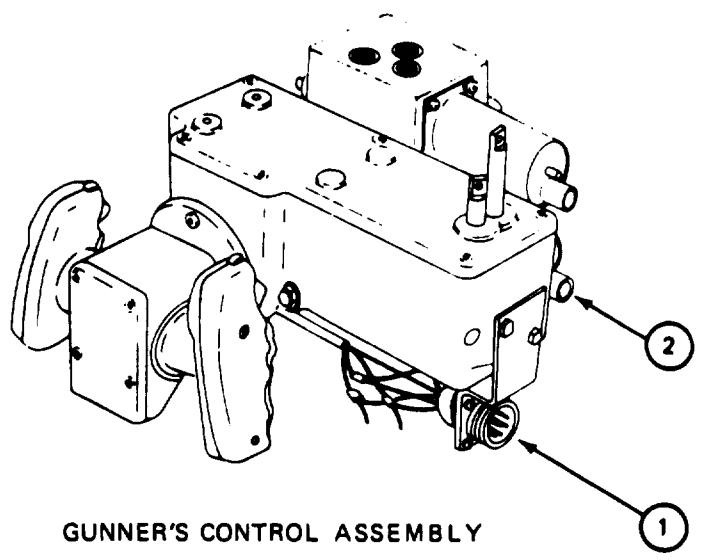
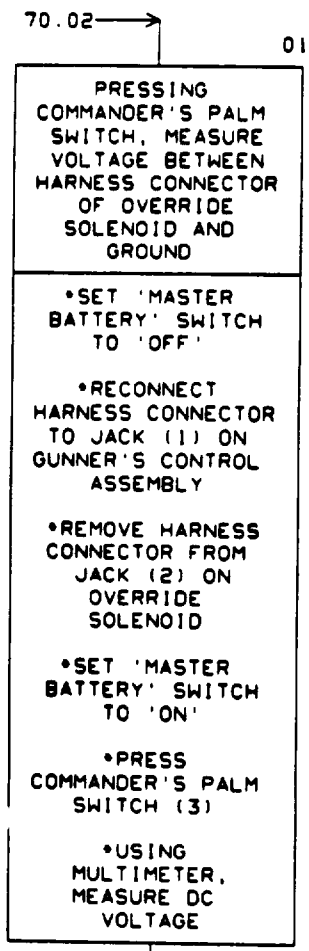

GUNNER'S CONTROL ASSEMBLY

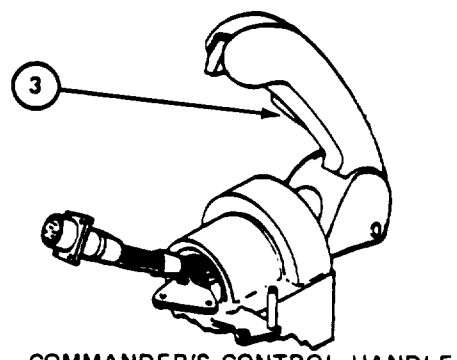

COMMANDER'S CONTROL HANDLE

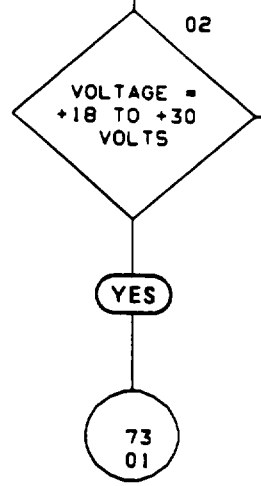

NO

DEFECTIVE GUNNER'S CONTROL ASSEMBLY WIRING HARNESS

•NOTIFY SUPPORT MAINTENANCE

4-1. TURRET TRAVERSE TROUBLESHOOTING (SHEET 73 OF 75)

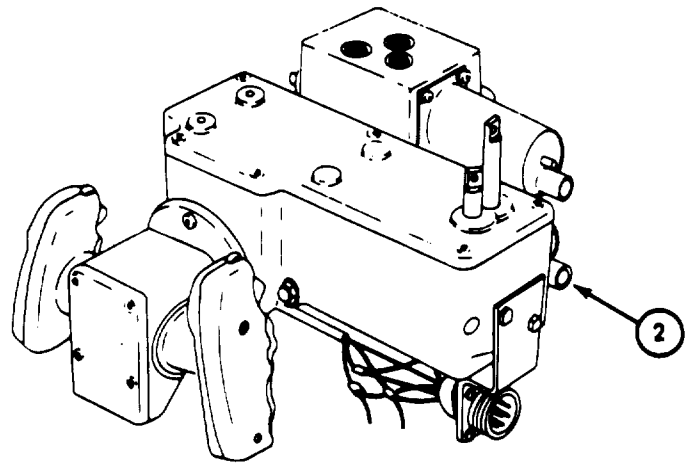
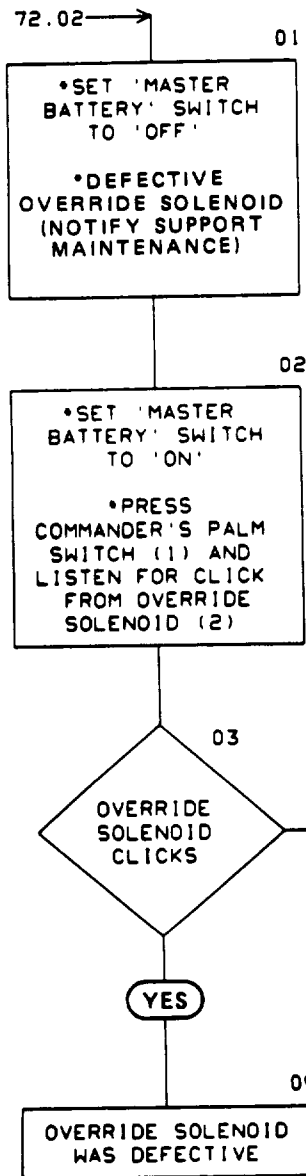

GUNNER'S CONTROL ASSEMBLY

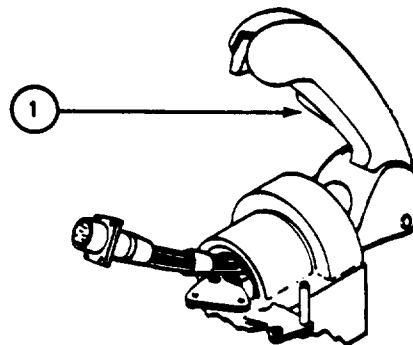

COMMANDER'S CONTROL HANDLE

4-1. TURRET TRAVERSE TROUBLESHOOTING (SHEET 74 OF 75)

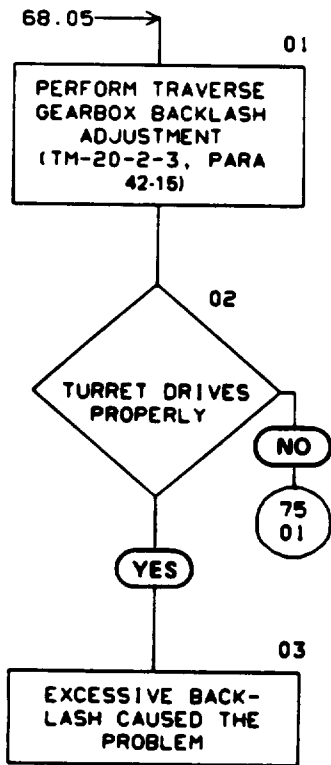

4-1. TURRET TRAVERSE TROUBLESHOOTING (SHEET 75 OF 75)

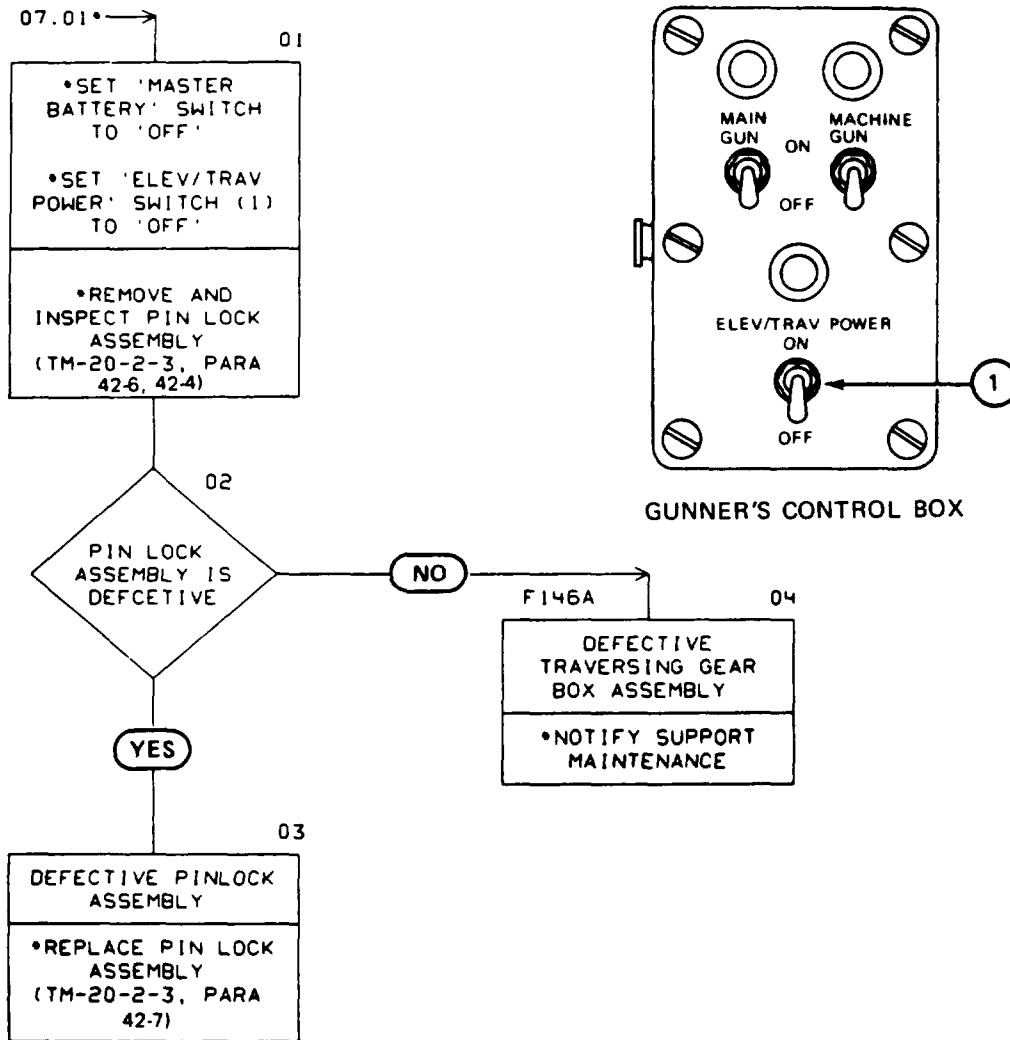

By Order of the Secretary of the Army:

E. C. MEYER
General, United States Army
Chief of Staff

Official:

J. C. PENNINGTON
Major General, United States Army
The Adjutant General

DISTRIBUTION:

To be distributed in accordance with DA Form 12-37 (Qty req block no. 1041) requirements for M728 Combat Engineer Vehicle.



SOMETHING WRONG WITH THIS MANUAL?

THEN... JOT DOWN THE DOPE ABOUT IT ON THIS FORM, TEAR IT OUT, FOLD IT AND DROP IT IN THE MAIL!

FROM: (YOUR UNIT'S COMPLETE ADDRESS)

Your mailing address.

DATE Date you fill out this form.

PUBLICATION NUMBER

TM 9-XXXX-XXX-XX

DATE

Date of TM

TITLE

Title of TM

BE EXACT... PIN-POINT WHERE IT IS

IN THIS SPACE TELL WHAT IS WRONG AND WHAT SHOULD BE DONE ABOUT IT:

PAGE NO.	PARA-GRAPH	FIGURE NO.	TABLE NO.
3		2	
109		51	
2-8			2-1
12	1-6a		

Item 10. Change illustration. Reason: Tube end shown assembled on wrong side of lever cam.

Item 3. The NSN and P/N are not listed on the AMDF nor the MCRL. Request correct NSN and P/N be furnished.

Preventive Maintenance Checks and Services. Item 7 under "Items to be inspected" should be changed to read as follows: Firing linkage and firing mechanism pawl.

Since there are both 20- and 30- round magazines for this rifle, data on both should be listed.

SAMPLE

TEAR ALONG DOTTED LINE

TYPED NAME, GRADE OR TITLE, AND TELEPHONE NUMBER

SIGN HERE:



SOMETHING WRONG WITH THIS MANUAL?

THEN... JOT DOWN THE DOPE ABOUT IT ON THIS FORM, TEAR IT OUT, FOLD IT AND DROP IT IN THE MAIL!

FROM: (YOUR UNIT'S COMPLETE ADDRESS)

DATE

PUBLICATION NUMBER

TM 9-2350-222-20-2-2-1

DATE

15 SEPT 1980

TITLE

COMBAT ENGINEER VEHICLE, M728, TURRET, VOL II, PART 1, TS

BE EXACT... PIN-POINT WHERE IT IS

IN THIS SPACE TELL WHAT IS WRONG AND WHAT SHOULD BE DONE ABOUT IT:

PAGE NO.	PARA-GRAPH	FIGURE NO.	TABLE NO.
----------	------------	------------	-----------

TEAR ALONG DOTTED LINE

TYPED NAME, GRADE OR TITLE, AND TELEPHONE NUMBER

SIGN HERE:

FILL IN YOUR
UNIT'S ADDRESS

FOLD BACK

DEPARTMENT OF THE ARMY

OFFICIAL BUSINESS

Commander
US Army Armament Materiel Readiness Command
ATTN: DRSAR-MAS
Rock Island, IL 61299

FOLD BACK

TEAR ALONG DOTTED LINE

FILL IN YOUR
UNIT'S ADDRESS



FOLD BACK

DEPARTMENT OF THE ARMY

OFFICIAL BUSINESS

Commander
US Army Armament Materiel Readiness Command
ATTN: DRSAR-MAS
Rock Island, IL 61299

TEAR ALONG DOTTED LINE

FOLD BACK



SOMETHING WRONG WITH THIS MANUAL?

THEN... JOT DOWN THE DOPE ABOUT IT ON THIS FORM, TEAR IT OUT, FOLD IT AND DROP IT IN THE MAIL!

FROM: (YOUR UNIT'S COMPLETE ADDRESS)

DATE

PUBLICATION NUMBER

TM 9-2350-222-20-2-2-1

DATE

15 SEPT 1980

TITLE

COMBAT ENGINEER VEHICLE, M728, TURRET, VOL II, PART 1, TS

BE EXACT... PIN-POINT WHERE IT IS

IN THIS SPACE TELL WHAT IS WRONG AND WHAT SHOULD BE DONE ABOUT IT:

PAGE NO.	PARA-GRAPH	FIGURE NO.	TABLE NO.

TEAR ALONG DOTTED LINE

TYPED NAME, GRADE OR TITLE, AND TELEPHONE NUMBER

SIGN HERE:

FILL IN YOUR
UNIT'S ADDRESS

FOLD BACK

DEPARTMENT OF THE ARMY

OFFICIAL BUSINESS

Commander
US Army Armament Materiel Readiness Command
ATTN: DRSAR-MAS
Rock Island, IL 61299

TEAR ALONG DOTTED LINE

FOLD BACK

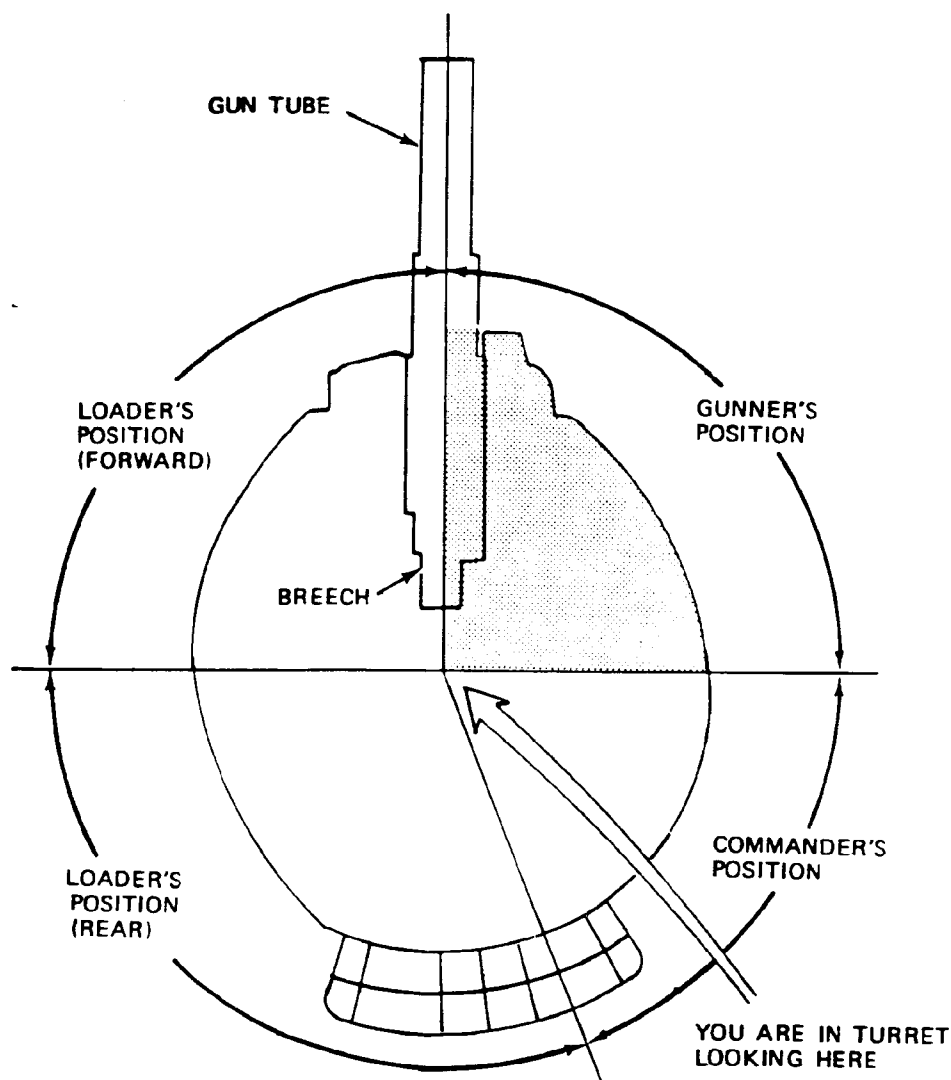

LEGEND:

- 1. GUNNER'S DOMELIGHT
- 2. GUNNER'S CONTROL BOX
- 3. HAND TRAVERSE DRIVE
- 4. GUNNER'S AIR FILTER HEATER
- 5. AZIMUTH INDICATOR
- 6. EQUILIBRATOR PRESSURE GAGE
- 7. EQUILIBRATOR CHARGING ASSEMBLY
- 8. POWER PACK BLOWER (HIDDEN)
- 9. TURRET POWER AND SEARCHLIGHT RELAY BOX (HIDDEN)
- 10. HYDRAULIC POWER PACK
- 11. PRESSURE SWITCH (HIDDEN)

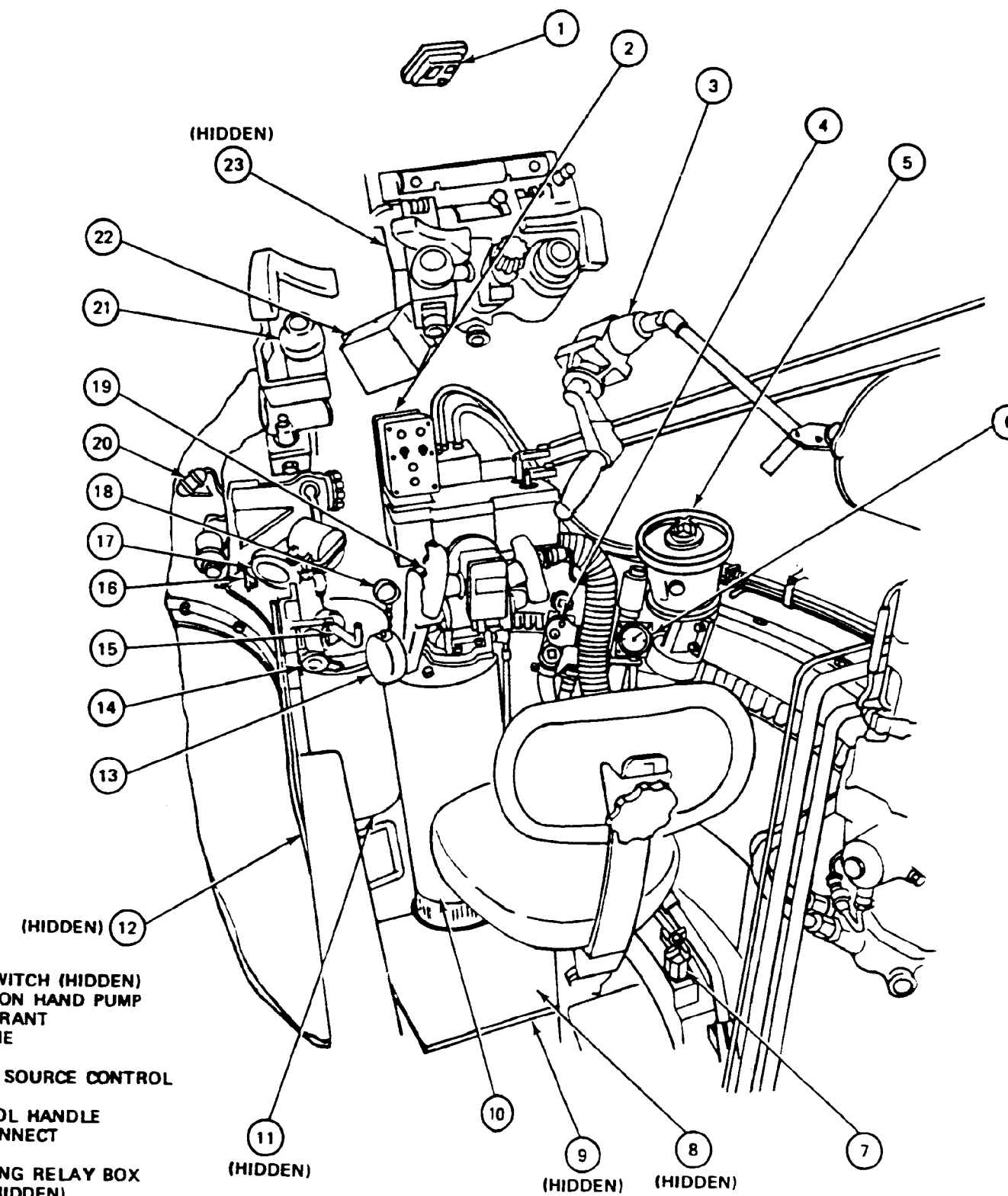

- 12. SAFETY RELAY SWITCH (HIDDEN)
- 13. MANUAL ELEVATION HAND PUMP
- 14. ELEVATION QUADRANT
- 15. BLASTING MACHINE
- 16. "Y" CONNECTOR
- 17. TELESCOPE LIGHT SOURCE CONTROL
- 18. PRESSURE GAGE
- 19. GUNNER'S CONTROL HANDLE
- 20. GUN QUICK DISCONNECT
- 21. TELESCOPE M105D
- 22. TURRET GUN FIRING RELAY BOX
- 23. INFINITY SIGHT (HIDDEN)

FO-1. EQUIPMENT LOCATION INFORMATION - GUNNER'S POSITION

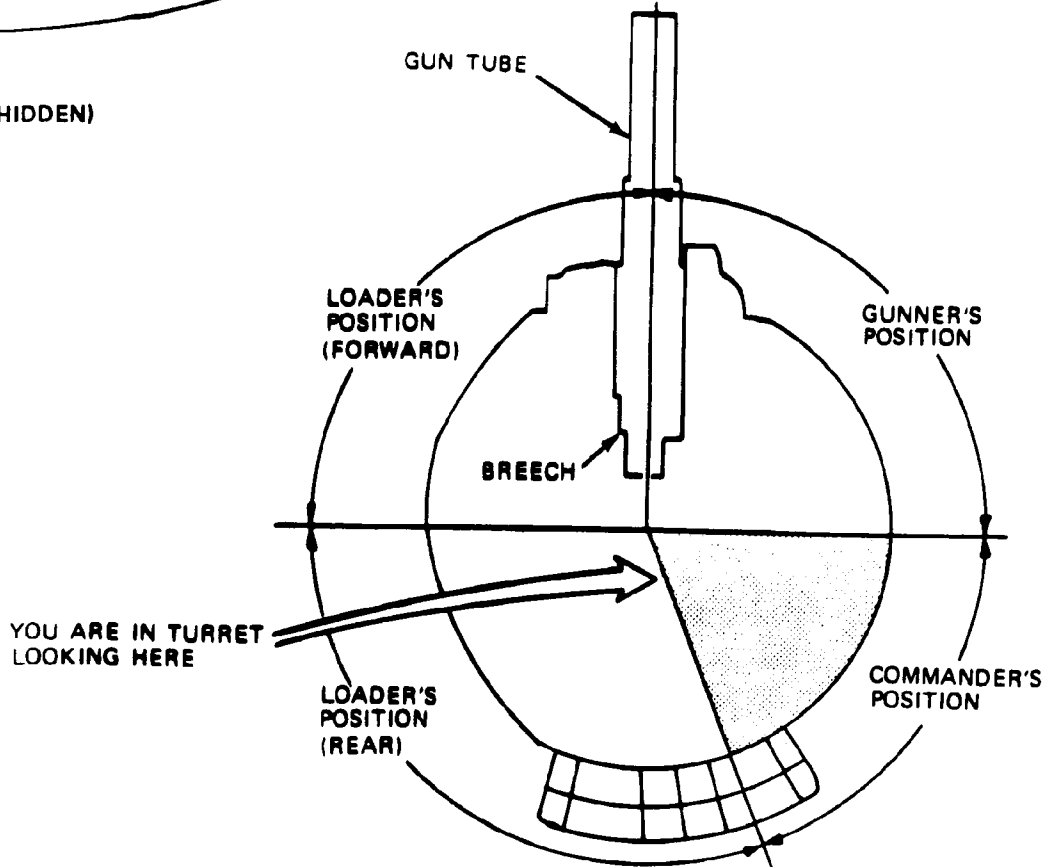
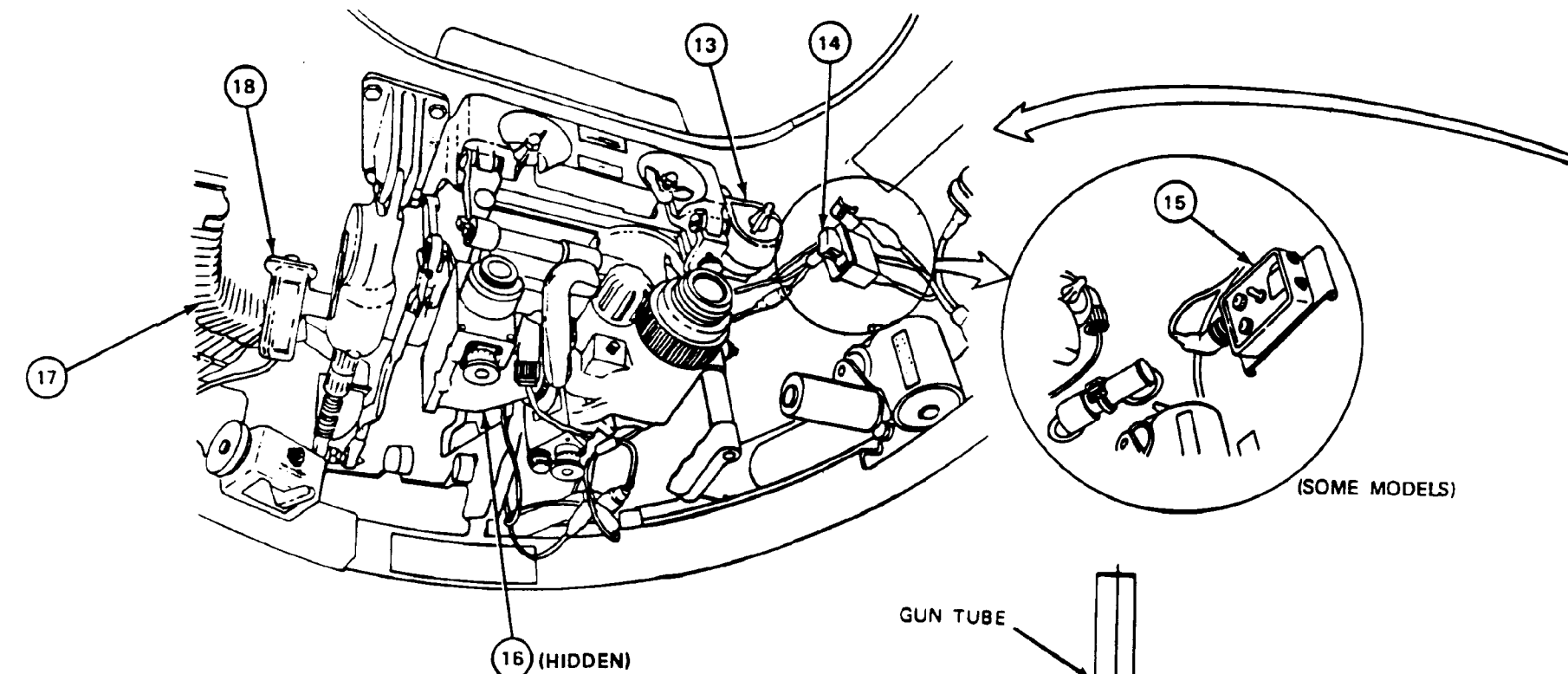

LEGEND:

1. CUPOLA POWER SWITCH, RELAY, AND RESISTOR ASSEMBLY
2. WINCH CONTROL LEVER
3. BOOM CONTROL LEVER
4. SEARCHLIGHT CONTROL BOX (AN/VSS-1)
5. COUNTERBALANCE AND SHUTTLE VALVES
6. CUPOLA INTERCONNECTING BOX
7. TURRET VENT BLOWER
8. COMMANDER'S AIR FILTER HEATER
9. WINCH COUNTERBALANCE RELIEF VALVE
10. WINCH-BOOM CONTROL VALVE
11. TURRET TRAVERSE MECHANISM
12. COMMANDER'S CONTROL HANDLE
13. COMMANDER'S PERISCOPE AND LIGHT SOURCE CONTROL
14. CUPOLA SAFETY SWITCH
15. COMMANDER'S CONTROL PANEL
16. CALIBER 0.50 MACHINE GUN (HIDDEN)
17. CALIBER 0.50 AMMO FEED CHUTE
18. ELEVATING HANDLE

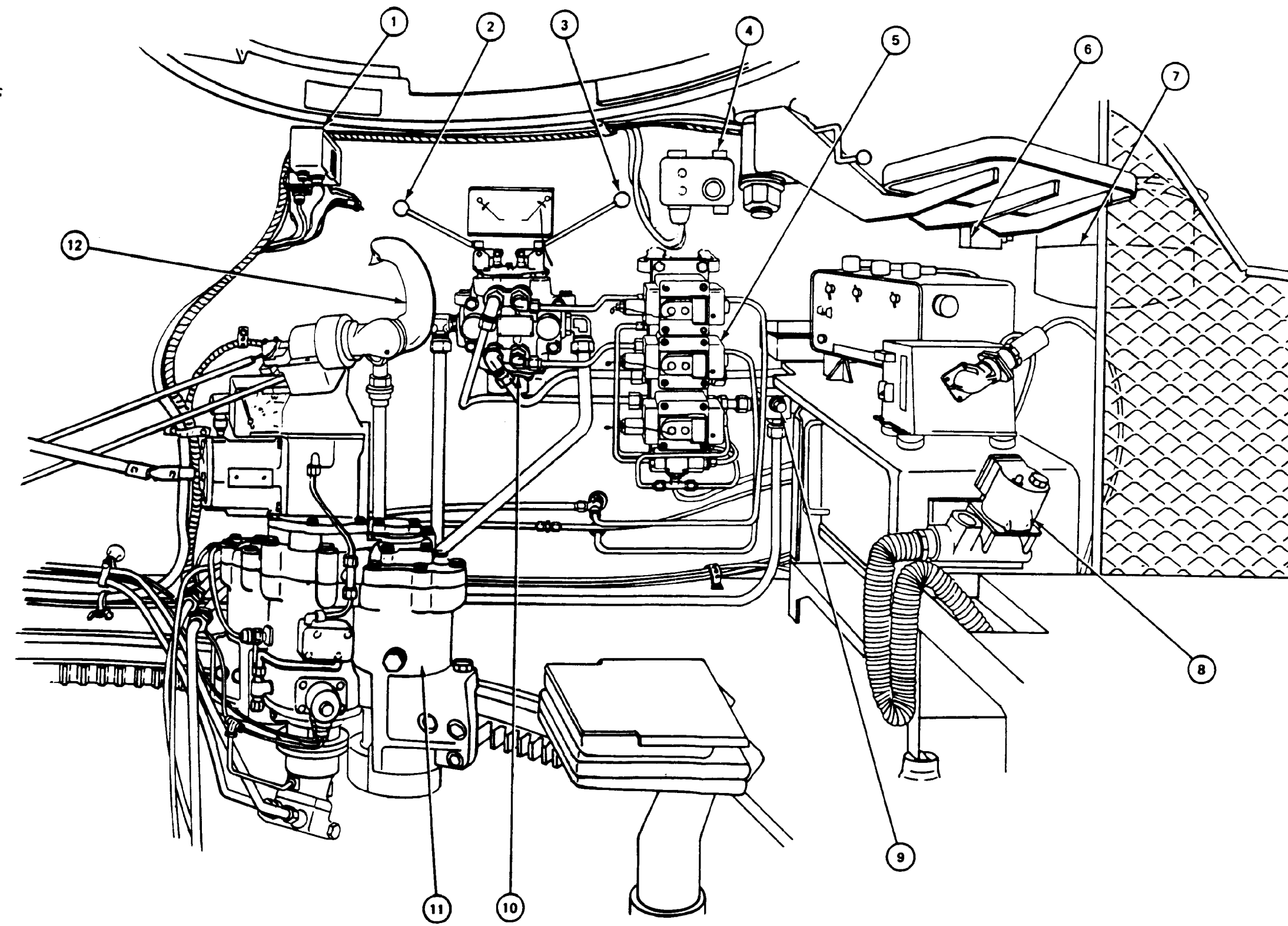

FO-2. EQUIPMENT LOCATION INFORMATION - COMMANDER'S POSITION

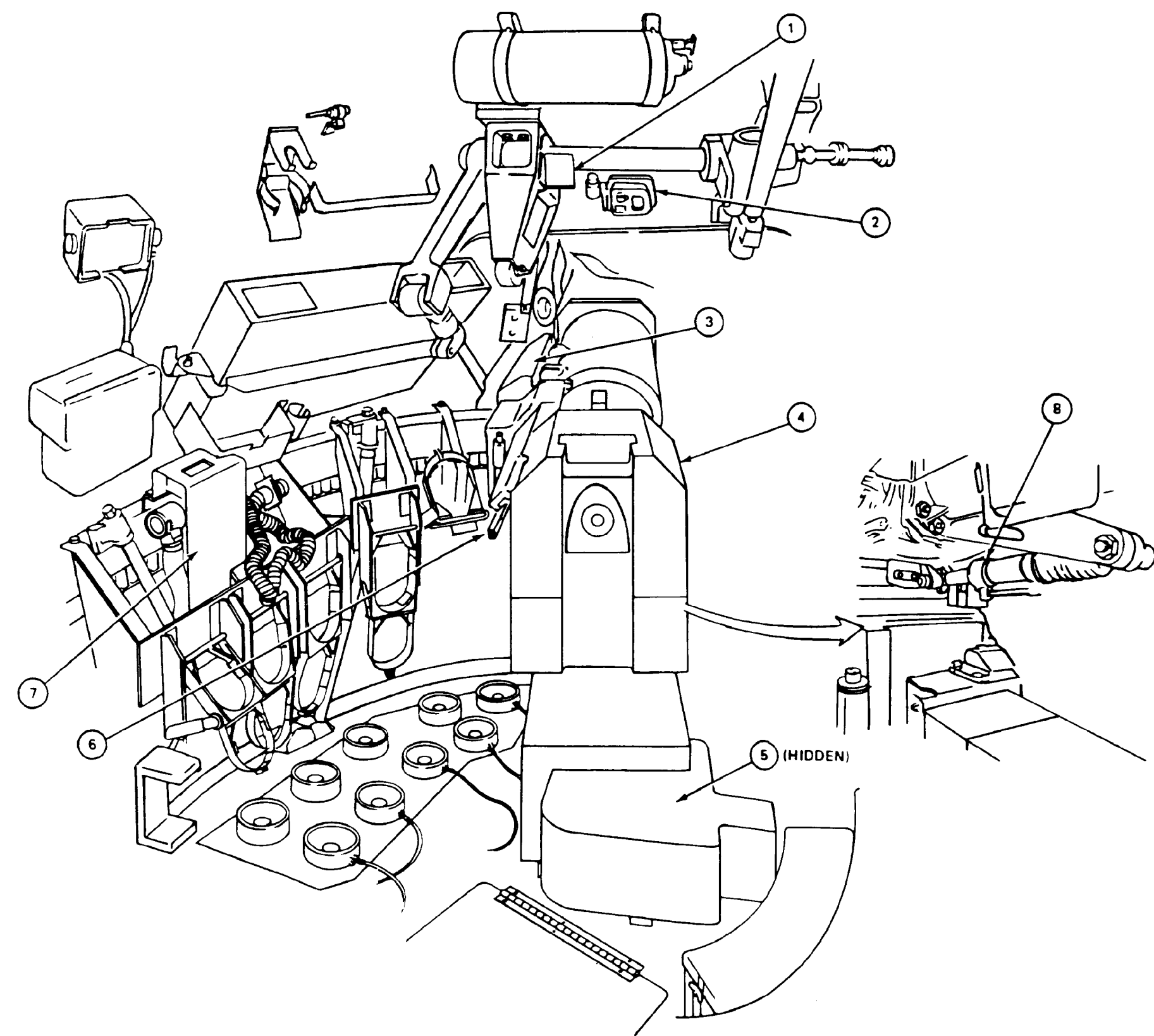
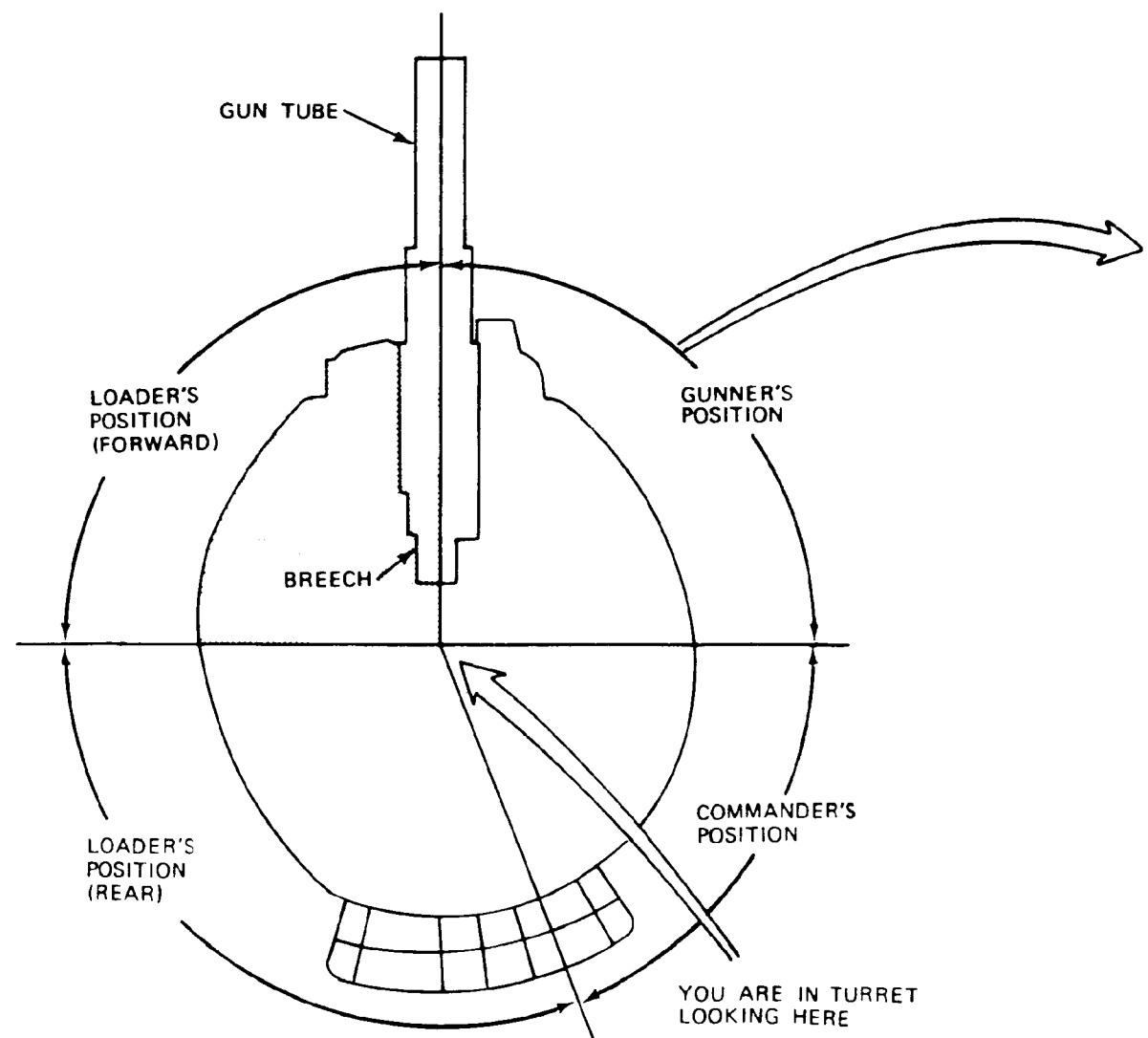

- LEGEND
- 1. GUN ELEVATION INTERFERENCE SWITCH
 - 2. LOADER'S DOMELIGHT
 - 3. 7.62 MM COAX MACHINE GUN
 - 4. BREECH RING
 - 5. TURRET ELECTRICAL SLIPRING (HIDDEN)
 - 6. LOADER'S SAFETY SWITCH
 - 7. LOADER'S AIR FILTER HEATER (HIDDEN)
 - 8. ELEVATING MECHANISM

FO-3. EQUIPMENT LOCATION INFORMATION - LOADER'S POSITION (FORWARD)

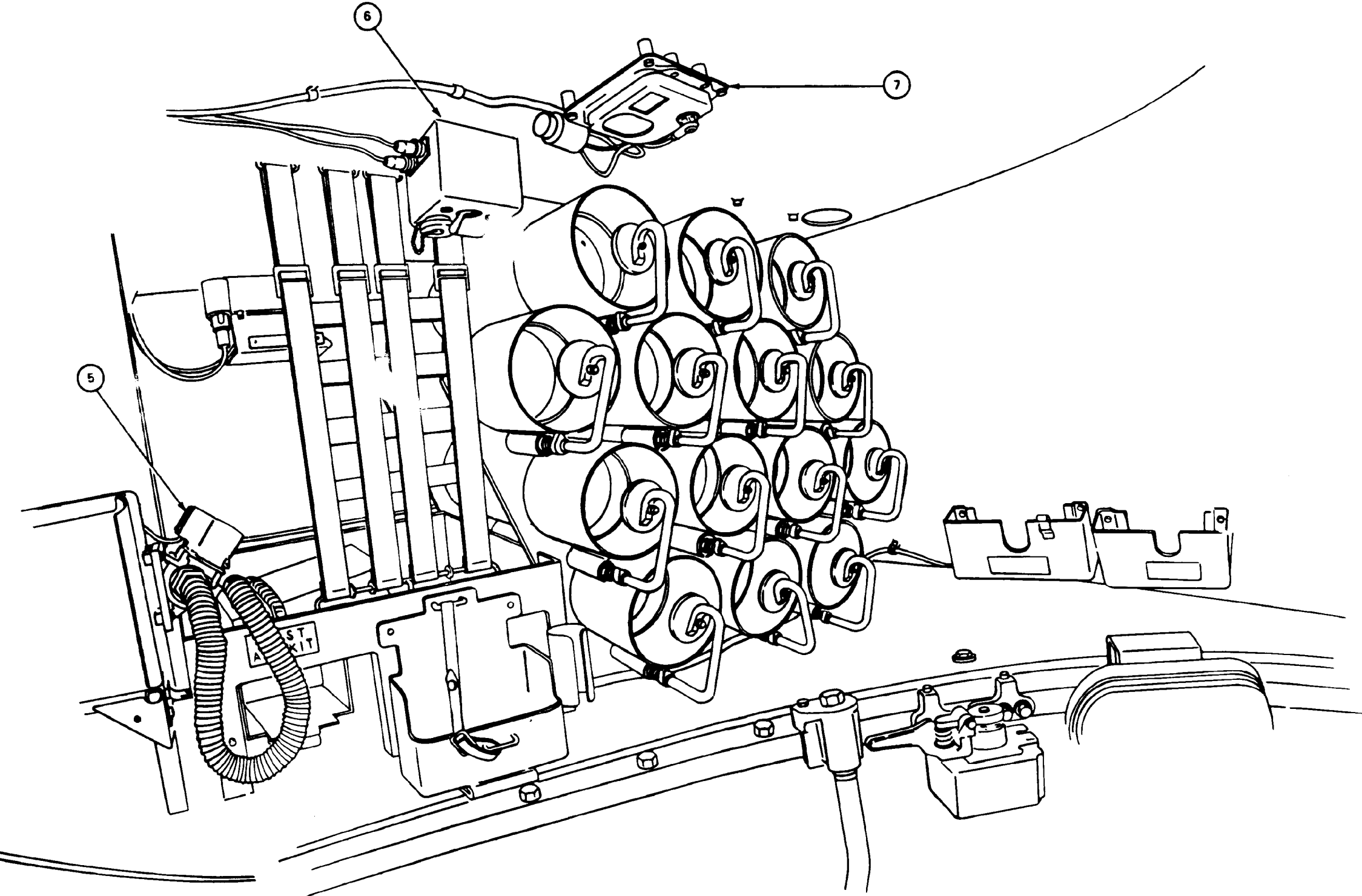
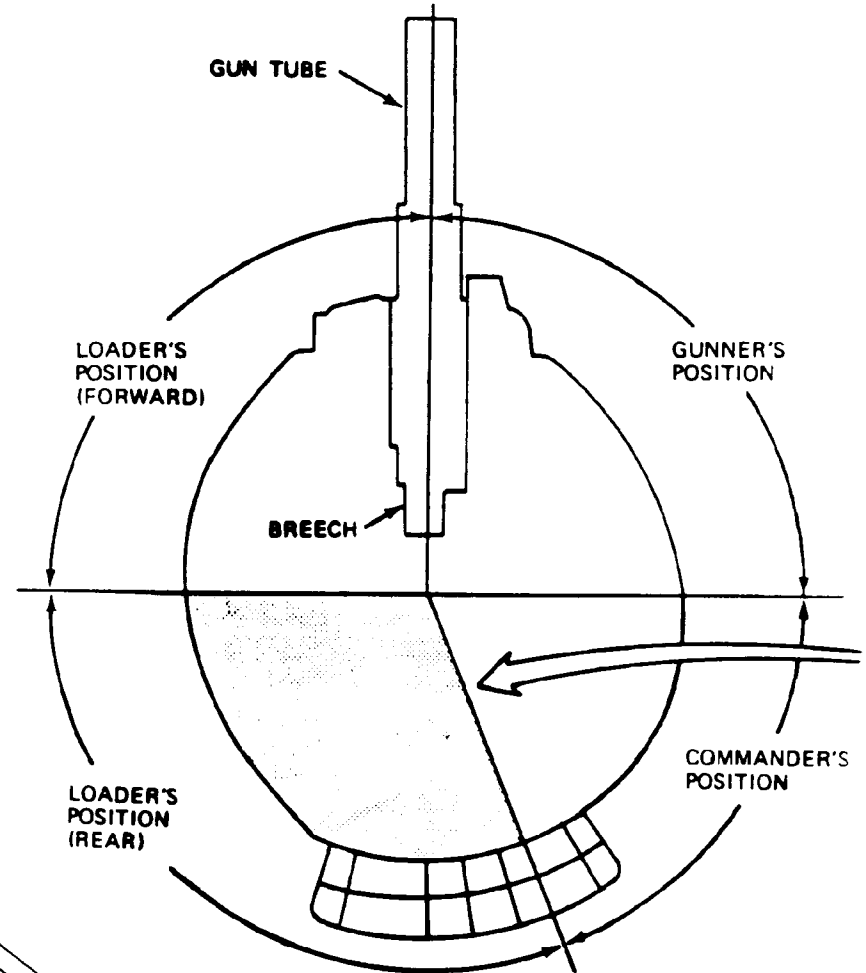
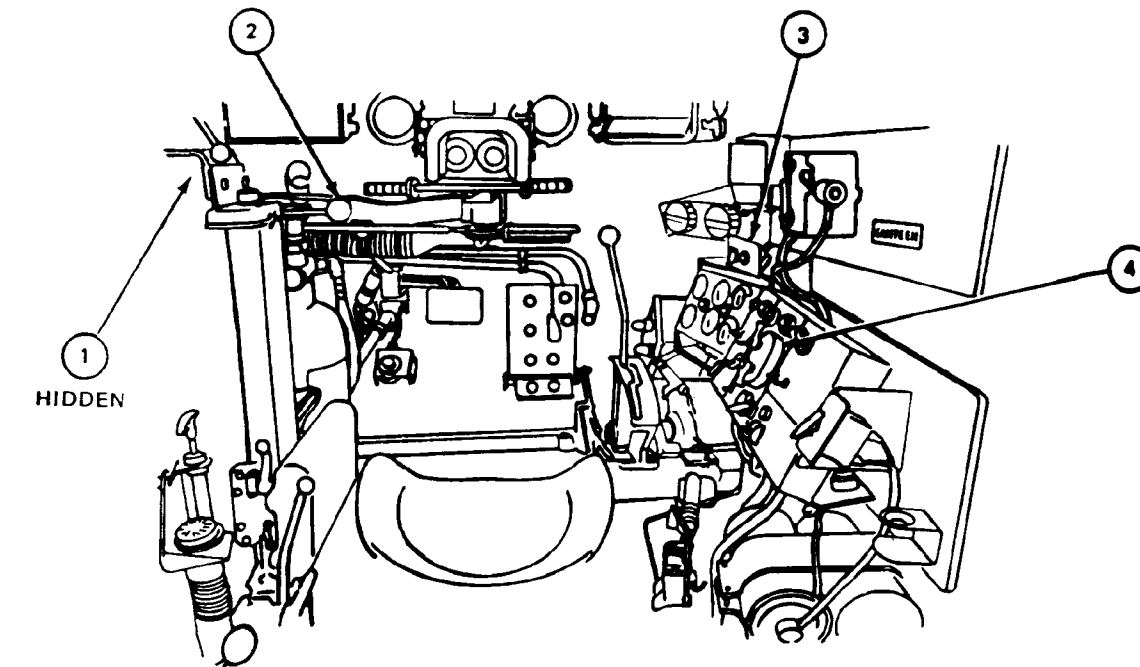

- LEGEND**
- 1. HYDRAULIC SELECTOR CONTROL VALVE LEVER (HIDDEN)
 - 2. MOLDBOARD DIRECTIONAL CONTROL VALVE LEVER
 - 3. HYDRAULIC PUMP SWITCH AND INDICATOR LAMP
 - 4. MASTER CONTROL PANEL
 - 5. LOADER'S AIR FILTER HEATER
 - 6. ACCESSORIES CONTROL BOX
 - 7. COMMANDER'S DOMELIGHT

FO-4. EQUIPMENT LOCATION INFORMATION - LOADER'S POSITION (REAR)

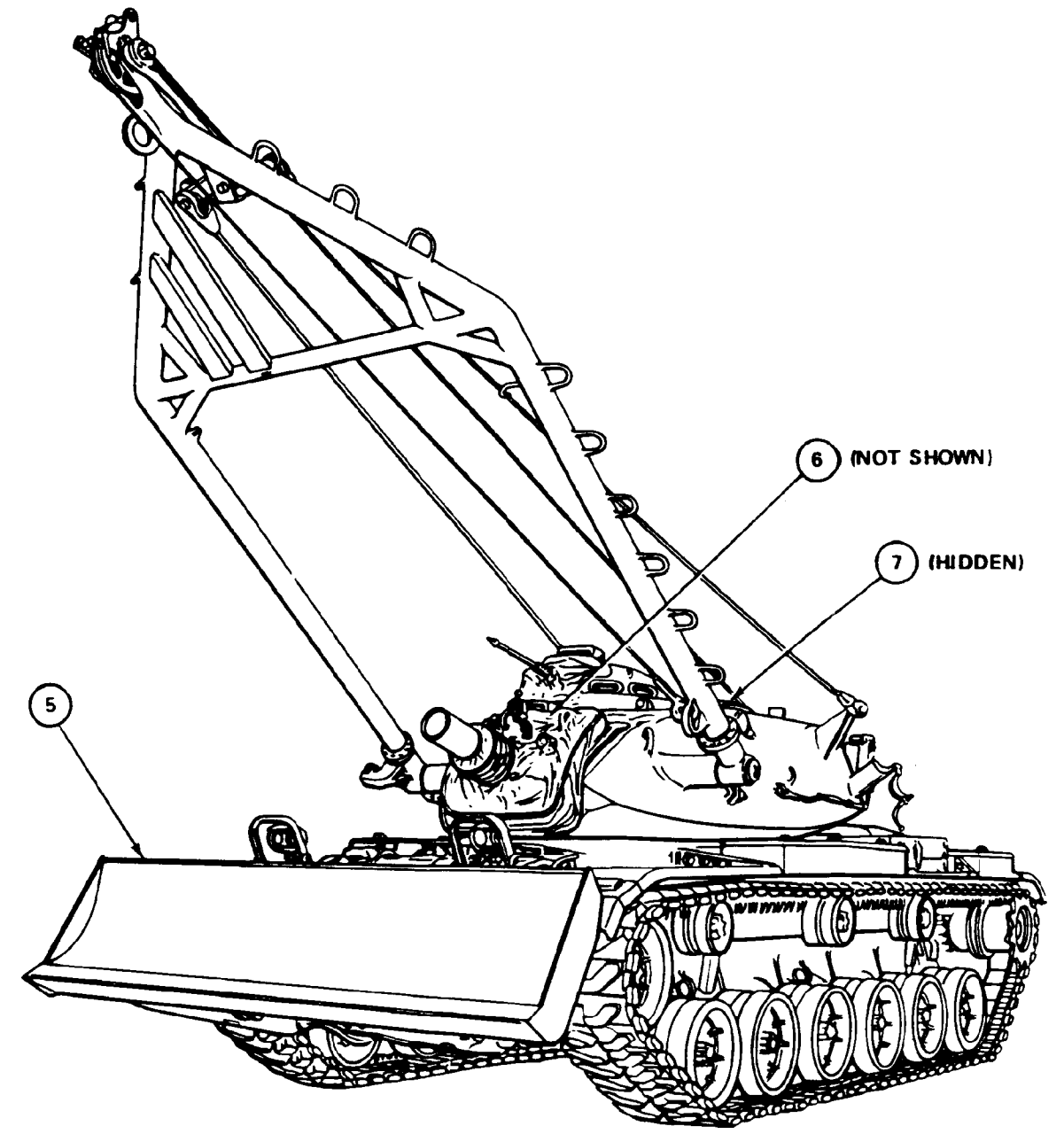
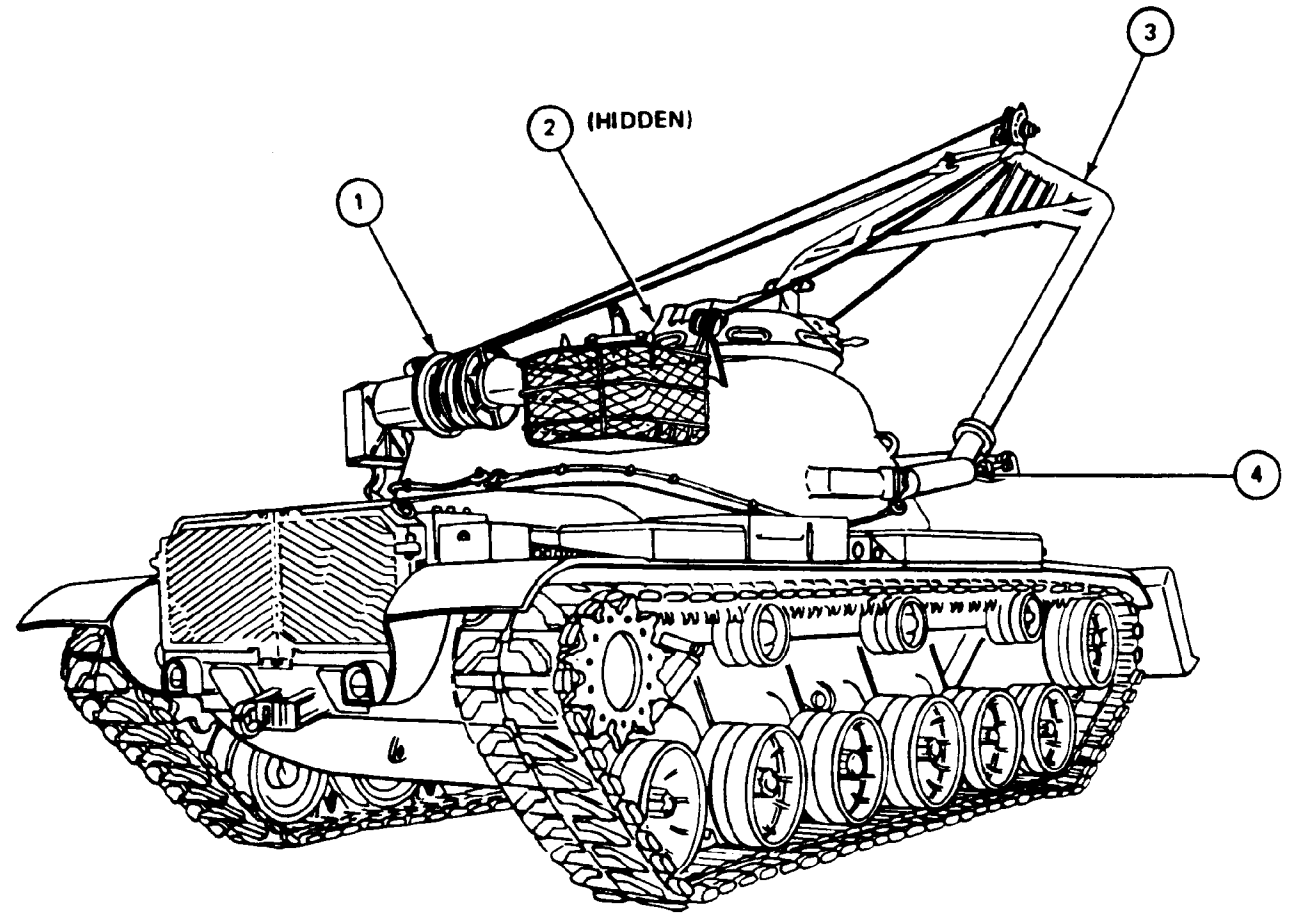

LEGEND

- 1. WINCH
- 2. WINCH GEARSHIFT LEVER (HIDDEN)
- 3. BOOM
- 4. BOOM ERECT CYLINDER
- 5. MOLDBOARD
- 6. SEARCHLIGHT (NOT SHOWN)
- 7. SEARCHLIGHT CONNECTOR (HIDDEN)

FO-5. EQUIPMENT LOCATION INFORMATION - OUTSIDE TANK

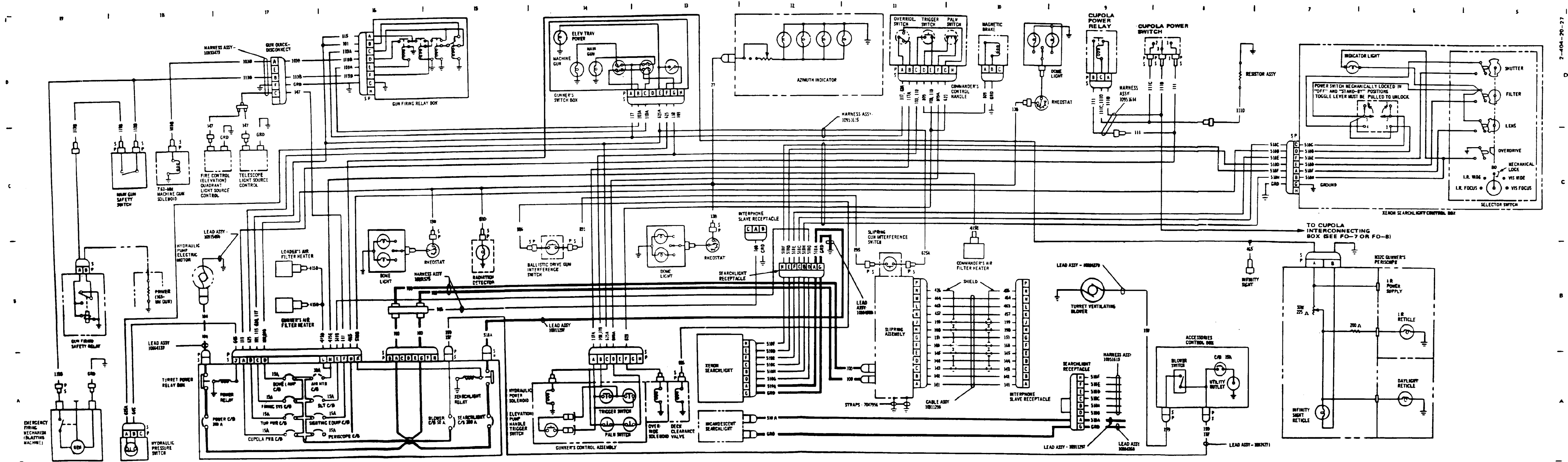

FO-6. TURRET ELECTRICAL SCHEMATIC DIAGRAM

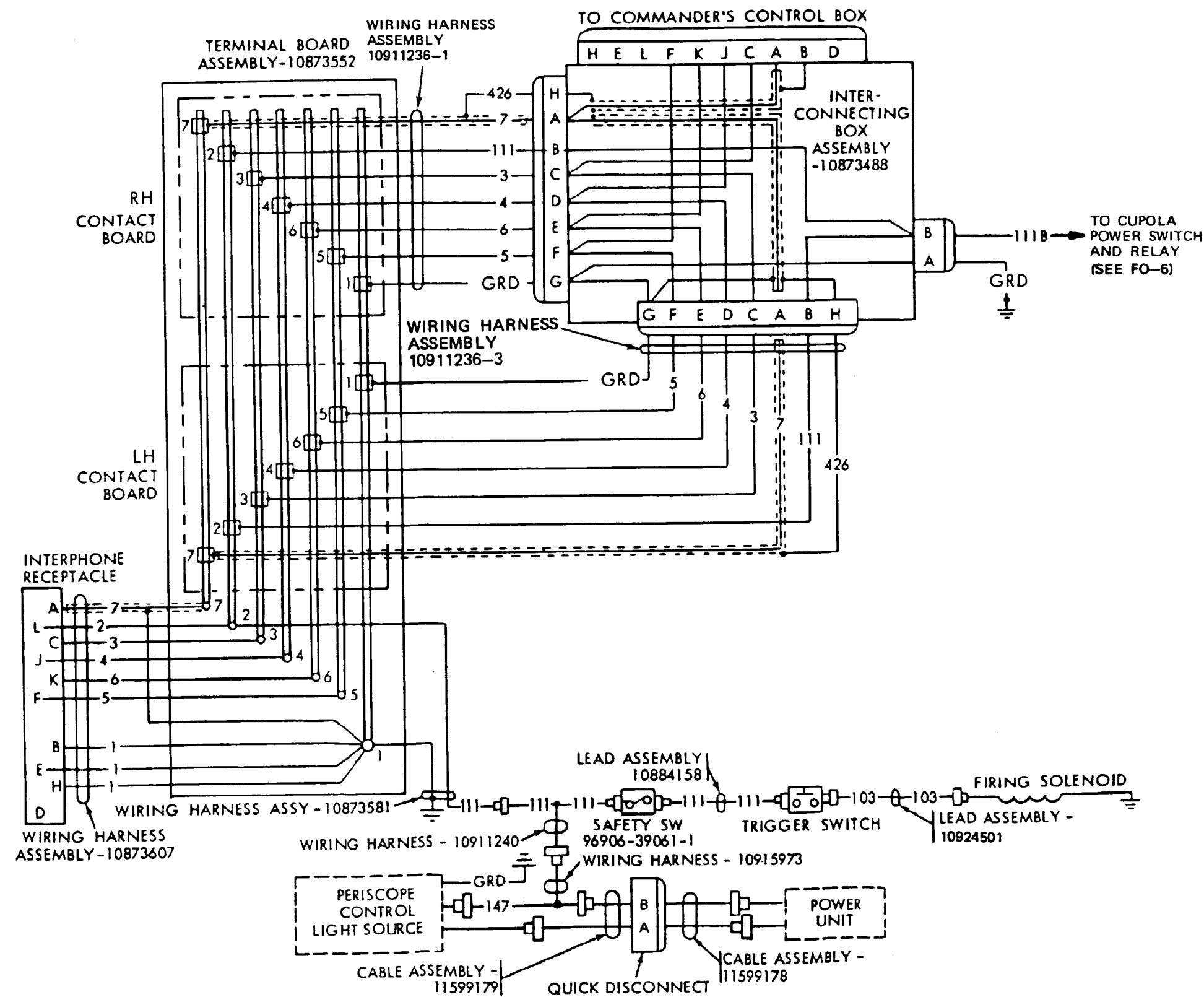

FO-7 CUPOLA ELECTRICAL SCHEMATIC DIAGRAM

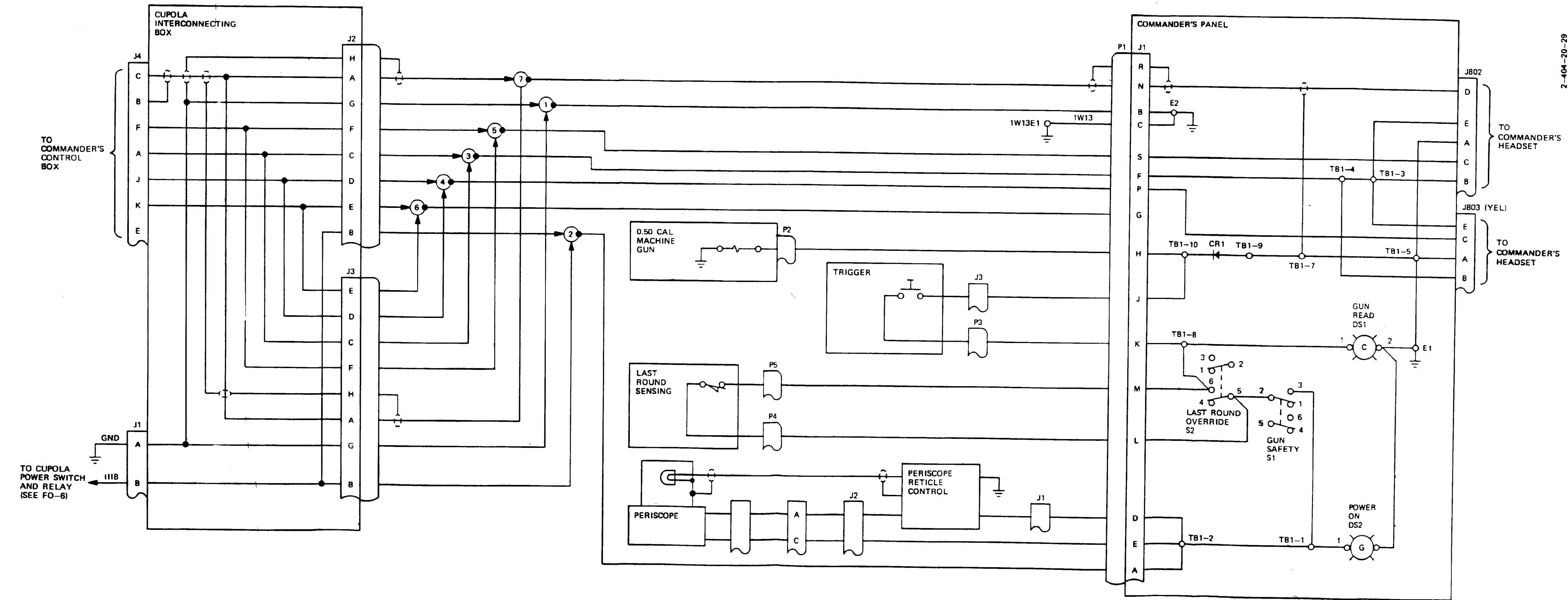

FO-8. CUPOLA ELECTRICAL SCHEMATIC DIAGRAM - LAST ROUND STOP INSTALLED

THE METRIC SYSTEM AND EQUIVALENTS

LINEAR MEASURE

1 Centimeter = 10 Millimeters = 0.01 Meters = 0.3937 Inches
 1 Meter = 100 Centimeters = 1000 Millimeters = 39.37 Inches
 1 Kilometer = 1000 Meters = 0.621 Miles

WEIGHTS

1 Gram = 0.001 Kilograms = 1000 Milligrams = 0.035 Ounces
 1 Kilogram = 1000 Grams = 2.2 Lb
 1 Metric Ton = 1000 Kilograms = 1 Megagram = 1.1 Short Tons

LIQUID MEASURE

1 Milliliter = 0.001 Liters = 0.0338 Fluid Ounces
 1 Liter = 1000 Milliliters = 33.82 Fluid Ounces

SQUARE MEASURE

1 Sq Centimeter = 100 Sq Millimeters = 0.155 Sq Inches
 1 Sq Meter = 10,000 Sq Centimeters = 10.76 Sq Feet
 1 Sq Kilometer = 1,000,000 Sq Meters = 0.386 Sq Miles

CUBIC MEASURE

1 Cu Centimeter = 1000 Cu Millimeters = 0.06 Cu Inches
 1 Cu Meter = 1,000,000 Cu Centimeters = 35.31 Cu Feet

TEMPERATURE

$5/9 (^{\circ}\text{F} - 32) = ^{\circ}\text{C}$
 212^o Fahrenheit is equivalent to 100^o Celsius
 90^o Fahrenheit is equivalent to 32.2^o Celsius
 32^o Fahrenheit is equivalent to 0^o Celsius
 $9/5 \text{ C}^{\circ} + 32 = \text{F}^{\circ}$

APPROXIMATE CONVERSION FACTORS

<u>TO CHANGE</u>	<u>TO</u>	<u>MULTIPLY BY</u>
Inches	Centimeters	2.540
Feet	Meters	0.305
Yards	Meters	0.914
Miles	Kilometers	1.609
Square Inches	Square Centimeters	6.451
Square Feet	Square Meters	0.093
Square Yards	Square Meters	0.836
Square Miles	Square Kilometers	2.590
Acres	Square Hectometers	0.405
Cubic Feet	Cubic Meters	0.028
Cubic Yards	Cubic Meters	0.765
Fluid Ounces	Milliliters	29.573
Pints	Liters	0.473
Quarts	Liters	0.946
Gallons	Liters	3.785
Ounces	Grams	28.349
Pounds	Kilograms	0.454
Short Tons	Metric Tons	0.907
Pound-Feet	Newton-Meters	1.356
Pounds per Square Inch	Kilopascals	6.895
Miles per Gallon	Kilometers per Liter	0.425
Miles per Hour	Kilometers per Hour	1.609

<u>TO CHANGE</u>	<u>TO</u>	<u>MULTIPLY BY</u>
Centimeters	Inches	0.394
Meters	Feet	3.280
Meters	Yards	1.094
Kilometers	Miles	0.621
Square Centimeters	Square Inches	0.155
Square Meters	Square Feet	10.764
Square Meters	Square Yards	1.196
Square Kilometers	Square Miles	0.386
Square Hectometers	Acres	2.471
Cubic Meters	Cubic Feet	35.315
Cubic Meters	Cubic Yards	1.308
Milliliters	Fluid Ounces	0.034
Liters	Pints	2.113
Liters	Quarts	1.057
Liters	Gallons	0.264
Grams	Ounces	0.035
Kilograms	Pounds	2.205
Metric Tons	Short Tons	1.102
Newton-Meters	Pound-Feet	0.738
Kilopascals	Pounds per Square Inch	0.145
Kilometers per Liter	Miles per Gallon	2.354
Kilometers per Hour	Miles per Hour	0.621

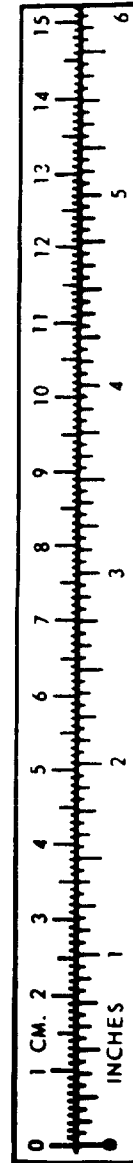

TA089991

